



**When
performance
counts most...**

PROFESSIONAL RECORDING
RADIO AND TV BROADCASTING
SOUND REINFORCEMENT SYSTEMS
AUDIOPHILE RECORDING
ENTERTAINMENT

MICROPHONES • HEADPHONES

**DATA
AND
PRICES
OCTOBER 1
1970**



K-120



K-60



K-36D

STEREO HEADPHONES

BOOM SETS

| | K-120 | | K-60 | | | K-36D | |
|--|----------------------------------|--|----------------------------------|--|--|---|--|
| TYPE | DYNAMIC STEREO | | DYNAMIC STEREO | | | DYNAMIC W/MICROPHONE | |
| DIRECTIONAL CHARACTERISTICS MICROPHONE Hz | | | | | |  | |
| FREQUENCY RESPONSE MICROPHONE Hz | | | | | | 70-12,000 | |
| FREQUENCY RESPONSE HEADPHONES Hz | 20-20,000 | | 20-20,000 | | | 20-20,000 | |
| SENSITIVITY MICROPHONE | | | | | | - 58 dB | |
| IMPEOANCE MATCHING HEADPHONES | 4 to 10,000 | | 4 to 10,000 | | | 4 to 10,000 | |
| WEIGHT | 12 oz. | | 11 oz. | | | 16 oz. | |
| CONNECTIONS | Prewired | | Prewired | | | Separate to each headphone and microphone | |
| ACCESSORIES INCLUDED | Standard 3-conductor stereo plug | | Standard 3-conductor stereo plug | | | | |
| PROFESSIONAL USER NET | \$22.50 | | \$39.50 | | | \$49.50 | |
| OPTIONAL ACCESSORIES | | | | | | | |



MICROPHONES • HEADPHONES ACCESSORIES

STANDS



RUBBER GRIP HANDLE



WINDSCREENS



W-17



W-2
W-3
W-4
W-7
W-8



W-24

W-9

CABLES



MK-7/S-5
connector switch



MK-7/TS-5

SUSPENSIONS



H-24
H-60



H-68
H-69

FLEXIBLE GOOSENECKS



MSH-58E
MSH-58E-2

SHOTGUN SYSTEMS



SA-7
(For W-24)



SA-11
SA-12
SA-15



SA-16
SA-20



SA-10/3



SA-18/6
SA-18/9



SA-18/1
SA-18/3

MK SERIES MODULAR CABLE ASSEMBLIES

Modular design of MK Series accessory microphone cable assemblies provide complete flexibility in adding additional functions to AKG microphones equipped with a Cannon XLR-3 connector.

Quick-disconnect conversion from low to high impedance with on-off operation is easy with MK-7/TS-5 cable assembly, which incorporates a built-in transformer with phone plug at the amplifier end and built-in switch at the microphone connector end.

The on-off switch is recessed inside the microphone connector. This unique concept preserves the aesthetic appearance of the microphone, and allows it to be hand-held with complete freedom from accidental switch operation. Added weight and distracting appearance is eliminated.

MK-7/S-5 cable assembly provides on-off flexibility only with the recessed switch/connector. MK-7/T-5 converts the microphone from low to high impedance without the switching facility.

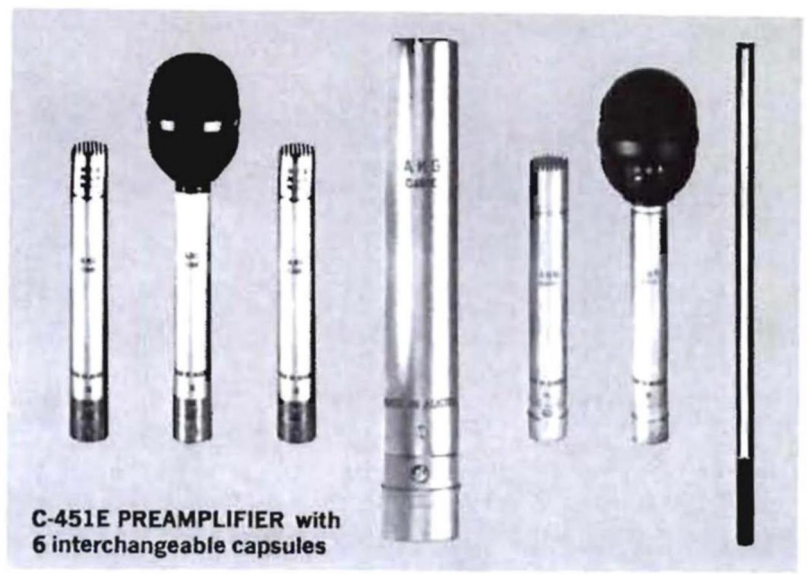

CONDENSER

| | C-12A | C-24 | C-451E COMBINATION | C-451E MODULAR COMPONENTS | C-451E/CK-1/CK-9 SHOTGUN SYSTEM |
|-------------------------------|---|--|---|--|---------------------------------|
| TYPE | CONDENSER | CONDENSER STEREO-TWIN | CONDENSER MODULAR | CK-1 Cardioid capsule \ominus \$60.00 CK-1S Cardioid capsule, rising response \$60.00 CK-2 Omni capsule \circ 60.00 CK-5 Cardioid capsule, shock-mount/windscreen 90.00 CK-6 Variable capsule. Omni to cardioid to figure-eight $\circ/\omega/8$ 120.00 CK-9 Interference tube (shotgun) $\{$ 120.00 B-46ES Battery power supply 45.00 N-46E a.c. power supply for two C-451E with bass cut and bass rolloff 150.00 N-48 Multiple a.c. power supply 50.00 PU7B A.C. power supply for 6 C-451E \$300.00 C-451E Preamplifier only for all capsules 98.00 VR-1 12" extension tube 40.00 VR-2 52" extension tube 110.00 A-50/10 10 dB pad 16.00 A-50/20 20 dB pad 16.00 A-51 Swivel 22.00 A-52 Phantom power module for 1 C-451E 14.00 KF-1 50 Hz bass cut filter 40.00 W-3 Windscreen for CK-1, CK-2 5.00 W-9 Windscreen for CK-9 22.00 W-17 Windscreen for CK-1, CK-2 22.00 H-60 Shock suspension, C-451E 16.50 H-69 Boom suspension, CK-9 46.00 SA-15 Stand adapter, C-451E 6.00 SA-18/1 Stand adapter, C-451E 16.50 SA-18/3 Stand adapter, CK-9 16.50 MC-20 20' microphone cable 14.00 MC-50 50' microphone cable 21.00 MK-15/1.5 Connector cable for N-48 15.00 | CONDENSER MODULAR |
| DIRECTIONAL CHARACTERISTICS | $\circ/\omega/8$ | $\circ/\omega/8$ | ω | ω \circ | ω \circ |
| FREQUENCY RESPONSE Hz | 20-20,000 | 20-20,000 | 30-20,000 | | |
| UNIFORMITY OF RESPONSE** | ± 2 dB | ± 2 dB | ± 2.5 dB | | |
| SENSITIVITY† | -44 dB | -39 dB | -39 dB | | |
| IMPEDANCE | 50/200 | 50/200 | 50/200 | | |
| FRONT-TO-BACK RATIO (1000 Hz) | 20 dB | 20 dB | 20 dB | | |
| DIMENSIONS IN INCHES | $3\frac{1}{8} \times 1\frac{1}{8} \times 1\frac{1}{4}$ | $10\frac{1}{8} \times 1\frac{1}{8}$ | $\frac{3}{4} \times 5\frac{1}{8}$ | | |
| WEIGHT | System 9 lbs. | System 29 lbs | 4.5 oz | | |
| CONNECTIONS | 1 = Shield 2 + 3 = Audio Cannon XLR-3 | 1 = Shield 2 + 3 = Audio Connector 5B17C | 1 = Shield 2 + 3 = Audio and phantom circuit supply voltage from amplifier Cannon XLR-3 | | |
| ACCESSORIES INCLUDED | Power supply w/built-in pattern selector Anti-shock stand adapter Cable set Case | Power supply Pattern selector Stand adapter Cable set Case | Stand adapter Windscreen Case | | |
| PROFESSIONAL USER NET | \$399.00 | \$885.00 | \$179.00 | | |
| OPTIONAL ACCESSORIES | W-11 Windscreen ST-200 Anti-shock floor stand ST-305 Anti-shock table stand | H-12 Anti-shock suspension ST-200 Anti-shock floor stand ST-305 Anti-shock table stand | See C-451E Components listing column. Special C-451E technical brochure with complete specifications and application information available on request or from your AKG dealer. | | |

**Relative to the published curve

†(re 1 mW/10 dynes/cm²)

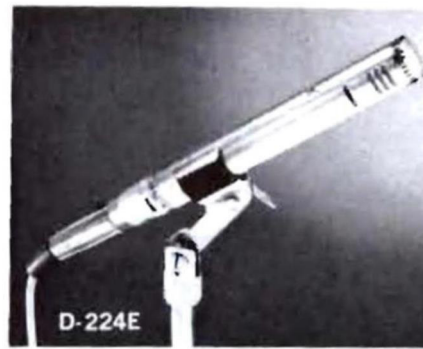
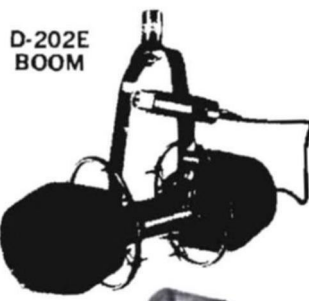

TWO-WAY CARDIOID DYNAMIC

OMNI-DIRECTIONAL

SHOTGUN DYNAMIC

| | D-200E D-200TS | D-202E D-202E BOOM | D-224E | D-160E | D-900E D-900E SYSTEM |
|-------------------------------|---|---|--|--|--|
| TYPE | DYNAMIC TWO-WAY | DYNAMIC TWO-WAY | DYNAMIC TWO-WAY | DYNAMIC | DYNAMIC INTERFERENCE/GRADIENT |
| DIRECTIONAL CHARACTERISTICS | | | | | |
| FREQUENCY RESPONSE Hz | 30-15,000 | 30-15,000 | 20-18,000 | 40-18,000 | 40-13,000 |
| UNIFORMITY OF RESPONSE** | ±3 dB | ±2 dB | ±2 dB | ± 2.5 dB | ±3 dB |
| SENSITIVITY† | -55 dB | -53 dB | -55 dB | -55 dB | -50 dB |
| IMPEDANCE | 200 | 200 | 200 | 200 | 200 |
| FRONT-TO-BACK RATIO (1000 Hz) | 18 dB | 20 dB | 20 dB | non-directional | 18 dB |
| DIMENSIONS IN INCHES | 7 ⁵ / ₈ x 1 ⁵ / ₈ | 8 ¹ / ₂ | 7 ³ / ₄ x 1 ⁵ / ₈ | 7 x 1 ³ / ₈ | 26 ¹ / ₈ x 1 ¹ / ₄ |
| WEIGHT | 8 oz. | 9.5 oz. | 9.5 oz. | 7.5 oz | 17 oz. |
| CONNECTIONS | 1 = Shield 2 + 3 = Moving Coil Canon XLR-3 | 1 = Shield 2 + 3 = Moving Coil Canon XLR-3 | 1 = Shield 2 + 3 = Moving Coil Canon XLR-3 | 1 = Shield 2 + 3 = Moving Coil Canon XLR-3 | 1 = Shield 2 + 3 = Moving Coil Canon XLR-3 |
| ACCESSORIES INCLUDED | SA-20 Stand adapter 15' cable T-119 Case | SA-16 Stand adapter 15' cable Case | SA-18/3 Stand adapter 15' cable Case | Stand adapter 15' cable Case | Stand adapter 15' cable Case |
| PROFESSIONAL USER NET | D-200E \$69.00 D-200TS \$84.00* | D-202E \$130.00 D-202E Boom* \$190.00 | \$185.00 | \$55.00 | D-900E \$149.00 D-900E SYSTEM \$246.00* |
| OPTIONAL ACCESSORIES | W-4 Windscreen SA-18/6 stand adapter Standard and anti-shock stands *D-200TS complete with on-off switch, Hi impedance transformer and phone plug. | W-7 Windscreen for standard D-202E only. SA-18/9 Stand adapter MK Series Cables (Boom Version complete with special suspension, front and rear wind screens) | W-2 Windscreen MK Series Cables Standard and anti-shock stands | MK Series Cables Standard and anti-shock stands | W-9 Windscreen SA-18/9 Stand adapter H-68 Boom suspension MK Series Cables *D-900E system is complete with SA-18/9 stand adapter, H-68 boom suspension, W-9 windscreen, MC-20 cable in fitted carrying case. |

**Relative to the published curve †(re 1 mW/10 dynes/cm²)



D-24 E



D-190ES



D-190E
D-190TS



D-707E
D-707TS



D-1000E
D-1000TS

CARDIOID DYNAMIC

| | D-24E | D-190ES | D-190E D-190TS | D-707E D-707TS | D-1000E D-1000TS |
|-------------------------------|---|--|--|--|---|
| TYPE | DYNAMIC | DYNAMIC W/ON-OFF SWITCH | DYNAMIC | DYNAMIC | DYNAMIC W/MODE SWITCH |
| DIRECTIONAL CHARACTERISTICS | | | | | |
| FREQUENCY RESPONSE Hz | 30-18,000 | 40-15,000 | 40-15,000 | 50-15,000 | 40-16,000 |
| UNIFORMITY OF RESPONSE** | ±2.5 dB | ±3 dB | ±3 dB | ±3.5 dB | ±3.5 dB |
| SENSITIVITY† | -52 dB | -53 dB | -53 dB | -53 dB | -52 dB |
| IMPEDANCE | 60 or 200 (specify) | 200 | 200 or Hi (specify) | 200 or Hi (specify) | 200 or Hi (Specify) |
| FRONT-TO-BACK RATIO (1000 Hz) | 18 dB | 20 dB | 20 dB | 15 dB | 18 dB |
| DIMENSIONS IN INCHES | 6½ x 1⅞ | 6¼ x 1½ | 6¼ x 1½ | 6 x 1⅞ | 6 x 1 ⅞ |
| WEIGHT | 6 oz. | 6 oz. | 6 oz | 4 oz. | 9½ oz. |
| CONNECTIONS | 1 = Shield 2 + 3 = Moving Coil Canon XLR-3 | 1 = Shield 2 + 3 = Moving Coil Canon XLR-3 | 1 = Shield 2 + 3 = Moving Coil Canon XLR-3 | 1 = Shield 2 + 3 = Moving Coil Canon XLR-3 | 1 = Shield 2 + 3 = Moving coil Canon XLR-3 |
| ACCESSORIES INCLUDED | SA-11 Stand adapter 15' Cable T-119 Case | SA-11 Stand adapter 15' Cable T-119 Case | SA-11 stand adapter 15' cable T-119 Case | SA-11 Stand Adapter 15' Cable T-119 Case | SA-12 Stand adapter 15' Cable T-119 Case |
| PROFESSIONAL USER NET | \$160.00 | \$55.00* | D-190E \$50.00 D-190TS \$65.00* | D-707E \$39.50 D-707TS \$49.50* | D-1000E \$60.00 D-1000TS \$75.00* |
| OPTIONAL ACCESSORIES | W-24 Windscreen H-24 Anti-shock suspension SA-10/3 Stand adapter (around connector) MK Series Cables Standard and anti-shock stands | W-8 Windscreen Standard and anti-shock stands *D-190ES is low impedance only with on-off switch on microphone. Order accessory MK-7/T-5 transformer/phone plug cable for high impedance use. | W-8 Windscreen Standard and anti-shock stands *D-190TS complete with on-off switch, Hi impedance transformer and phone plug. | W-4 Windscreen Standard and anti-shock stands *D-707TS complete with on-off switch, Hi impedance transformer and phone plug. | W-4 Windscreen Standard and anti-shock stands *D-1000TS complete with on-off switch, Hi impedance transformer and phone plug. |

**Relative to the published curve

†(re 1 mW/10 dynes/cm²)



LAVALIER DYNAMIC

SPECIAL PURPOSE DYNAMIC

| | D-109 | D-110 SHOCK MOUNTED* | D-58E | D-503 | D-507 |
|-------------------------------|---|---|---|---|---|
| TYPE | DYNAMIC LAVALIER | DYNAMIC LAVALIER | NOISE-CANCELLING DIFFERENTIAL | DYNAMIC | NOISE-CANCELLING DIFFERENTIAL |
| DIRECTIONAL CHARACTERISTICS | | | | | |
| FREQUENCY RESPONSE Hz | 50-15,000 | 50-15,000 | 70-12,000 | 50-15,000 | 70-12,000 |
| UNIFORMITY OF RESPONSE** | ±5 dB | ±5 dB | ± 5 dB | ±3.5 dB | ± 5 dB |
| SENSITIVITY† | -56 dB | -56 dB | -58 dB | -52 dB | -54 dB |
| IMPEDANCE | 200 | 200 | 60 or 200 (specify) | 200 | 200 |
| FRONT-TO-BACK RATIO (1000 Hz) | non-directional | non-directional | 25 dB | 15 dB | 18 dB |
| DIMENSIONS IN INCHES | 2 $\frac{3}{4}$ x $\frac{5}{8}$ | 3 $\frac{3}{8}$ x $\frac{29}{32}$ | 1 $\frac{5}{8}$ x $\frac{13}{16}$ | W/shaft 17 $\frac{3}{5}$ x2 $\frac{3}{16}$ | W/shaft 17 $\frac{3}{5}$ x2 $\frac{3}{16}$ |
| WEIGHT | 1.5 oz. | 2.75 oz. | 1.1 oz. | 15.5 oz. | 15.5 oz. |
| CONNECTIONS | 1 = Shield 2 = Red (in phase) 3 = White Non-detachable cable | 1 = Shield 2 = Red (in phase) 3 = White Non-detachable cable | 1 = Shield 2 + 3 = Moving Coil Canon XLR-3 | 1 = Shield 2 = Red (in phase) 3 = White Non-detachable cable | 1 = Shield 2 = Red (in phase) 3 = White Non-detachable cable |
| ACCESSORIES INCLUDED | Neck cord w/ tie clip 30' cable Case | Neck cord w/ tie clip 30' cable Case | Built-in connector Case | 13 $\frac{1}{2}$ " flexible gooseneck with cable | 13 $\frac{1}{2}$ " flexible gooseneck with cable |
| PROFESSIONAL USER NET | \$49.00 | \$80.00 | \$43.00 | \$55.00 | \$55.00 |
| OPTIONAL ACCESSORIES | | *With internally suspended capsule. | W-3 Windscreen MSH-58E 8" flexible gooseneck MSH-58E-2 20" flexible gooseneck MK Series Cables Standard and anti-shock stands | Standard and anti-shock stands | Standard and anti-shock stands |

**Relative to the published curve

†(re 1 mW/10 dynes/cm²)

AKG MICROPHONE ACCESSORIES

| | | User Net | | | User Net |
|-----------------------------------|--|----------|---|---|----------|
| MICROPHONE TABLE STANDS | | | MICROPHONE CASE | | |
| ST-4 | Table Stand | \$12.00 | T-119 | Microphone case | 2.00 |
| ST-305 | Anti-shock table stand | 19.50 | HEADPHONE EAR CUSHIONS | | |
| MICROPHONE FLOOR STANDS | | | Z-60 | Adapter for K-60 ear cushion, replacement pair | 2.25 |
| ST-101 | Heavy duty floor stand with collapsible base | 24.00 | Z-61 | Ear cushion for K-60, replacement pair | 3.00 |
| ST-200 | Anti-shock floor stand with collapsible base | 47.00 | CABLES FOR CONDENSER MICROPHONES | | |
| ST-201 | Lightweight floor stand with folding base | 21.00 | MK-12A/20 | Power supply cable for C-12A Connects N-12A power supply to V-12A microphone amplifier. 66' long with two connectors | 92.00 |
| WINDSCREENS | | | NF-12A/5 Audio | Audio output cable with one connector for N-12A power supply, 15' long with free end | 22.00 |
| W-2 | Windscreen for D-224E. Foam type | 5.00 | MK-24/20 | Same as MK-12A/20 but for C-24 | 92.00 |
| W-3 | Windscreen for D-58E, C-451E. Foam Type | 5.00 | NF-24/5 | Same as NF-12A/5, but for C-24 | 22.50 |
| W-4 | Windscreen for D-200E, D-1000E. Foam Type | 6.00 | RL-24/10 | Pattern selector cable for C-24 | 44.00 |
| W-7 | Windscreen for D-202E Foam Type | 7.00 | MK-15/1.5 | Connector cable for N-48 | 15.00 |
| W-8 | Windscreen for D-190E/ES/TS Foam type | 7.00 | POWER SUPPLIES FOR CONDENSER MICROPHONES | | |
| W-9 | Windscreen for CK-9, D900E shotguns. Foam | 22.00 | B-46ES | 9 volt d.c. battery power supply for C-451E. On-off switch and cannon connectors for in-line use | 45.00 |
| W-9A | Rear Windscreen for D-900E and D-202E | 6.00 | N-12A | Power Supply for C-12A | 180.00 |
| W-17 | Windscreen for C-451E. (CK-1, CK-2) | 22.00 | N-24 | Power Supply for C-24 | 192.00 |
| W-24 | Windscreen for D-19E/200, D-24E | 31.00 | N-46E | A.C. power supply for two C-451E. Individual bass roll-off and bass cut. Trim plate for rack panel mounting | 150.00 |
| STAND ADAPTERS | | | N-48 | Multiple a.c. power supply to feed to 20 C-451E; with MK-15/1.5 | 50.00 |
| SA-7 | Stand Adapter for W-24 Windscreen (Replacement) | 6.00 | PU7B | A.C. power supply for 6 C-451E | 300.00 |
| SA-10/3 | Stand Adapter for all microphones with Cannon XLR. Fits around connector | 7.00 | A-52 | Phantom powering module for 1 C-451E | 14.00 |
| SA-11 | Stand Adapter for D-19E/200, D-119ES, D-24E, D-190E, D-707E (Replacement) | 3.00 | EXTENSION TUBES AND SWIVEL FOR C-451E | | |
| SA-12 | Stand Adapter for D-1000E (Replacement) | 3.00 | VR-1 | 12" extension tube for C-451E. (CK-1, CK-2, CK-6) | 40.00 |
| SA-15 | Stand Adapter for C-451E, D-150 | 6.00 | VR-2 | Same as VR-1, except 52" long with swivel mount | 110.00 |
| SA-16 | Stand Adapter for D-202E, D-900E (Replacement) | 3.00 | A-51 | Swivel for C-451E. (CK-1, CK-2, CK-6) | 22.00 |
| SA-18/1 | Stand Adapter for C-451E. Metal w/locking clamp | 16.50 | AMPLIFIERS FOR CONDENSER MICROPHONES | | |
| SA-18/3 | Stand Adapter for D-224E, CK-9, D-900E. Metal | 16.50 | C-451E | Preamplifier module only for use with CK-1, CK-1S, CK-2, CK-5, CK-6, CK-9 Condenser Capsules | 98.00 |
| SA-18/6 | Stand Adapter for D-200E, Metal w/locking clamp | 16.50 | V-12A | Amplifier with microphone capsule for C-12A system (Replacement) | 230.00 |
| SA-18/9 | Stand Adapter for D-202E, D-900E. Metal, locking | 16.50 | V-24 | Amplifier with 2 microphone capsules for C-24 system (Replacement) | 470.00 |
| SA-20 | Stand Adapter for D-200E (Replacement) | 3.00 | CAPSULES FOR C-451E PREAMPLIFIER—INTERCHANGEABLE | | |
| ANTI-SHOCK SUSPENSIONS | | | CK-1 | Cardioid condenser microphone capsule only for C-451E | 60.00 |
| H-7 | Rubber "pistol grip" handle for SA-18 adapters | 12.00 | CK-1S | Cardioid condenser microphone capsule with rising response | 60.00 |
| H-24 | Anti-shock suspension for D-19E/200, D119ES, D-24E, D-190E, D-707E | 16.50 | CK-2 | Omni-directional condenser microphone capsule only for C-451E | 60.00 |
| H-60 | Anti-shock stand suspension for C-451E | 16.50 | CK-5 | Cardioid condenser microphone capsule with integral shock mount and windscreen | 90.00 |
| H-68 | Anti-Shock Stand Suspension for D-900E | 46.00 | CK-6 | Variable pattern omni/cardioid/figure-eight condenser microphone capsule only for C-451E | 120.00 |
| H-69 | Anti-shock boom suspension for D-224E and CK-9, D-900E shotguns | 46.00 | CK-9 | Interference tube (shotgun) with built-in condenser microphone capsule only for C-451E | 120.00 |
| FLEXIBLE GOOSENECKS | | | BASS FILTER AND OUTPUT PADS | | |
| MSH-58E | 8" flexible gooseneck with connector for D-24E, D-58E, D-19E/200, D-200E, D-707E, D-190E | 17.00 | KF-1 | 50 Hz bass cut-off, in-line filter | 40.00 |
| MSH-58E-2 | 20" flexible gooseneck with connector for D-24E, D-58E, D-19E/200, D-200E, D-707E, D-190E | 20.00 | KF-2 | 10 dB in-line output pad | 30.00 |
| CABLES FOR ALL MICROPHONES | | | A-50/10 | 10 dB pad for C-451E preamplifier | 16.00 |
| MC-20 | 20' microphone cable complete with XLR-3 type male and female connectors | 14.00 | A-50/20 | 20 dB pad for C-451E preamplifier | 16.00 |
| MC-50 | 50' microphone cable complete with XLR-3 type male and female connectors | 21.00 | | | |
| MK-7/T-5 | 15' microphone cable assembly with built-in low to high impedance transformer/phone plug. For all microphones with Cannon XLR-3 connector | 16.00 | | | |
| MK-7/S-5 | Microphone cable with on-off switch built-in to microphone connectors and free end for amplifier connection. For all microphones with Cannon XLR-3 connector | 14.50 | | | |
| MK-7/TS-5 | Microphone cable assembly complete with built-in low to high impedance transformer/phone plug and on-off connector/switch. For all microphones with Cannon XLR-3 connector | 21.50 | | | |



MICROPHONES • HEADPHONES

DISTRIBUTED BY
NORTH AMERICAN PHILIPS CORPORATION
 100 EAST 42ND STREET, NEW YORK, NEW YORK 10017
 TELEPHONE (212) 697-3600

AKG Service Department 30-30 Review Avenue
 Long Island City, N.Y. 11101 • Tel. (212) 786-6400