

TONEARM WITH SLIDE BASE MOUNT

ALT-1

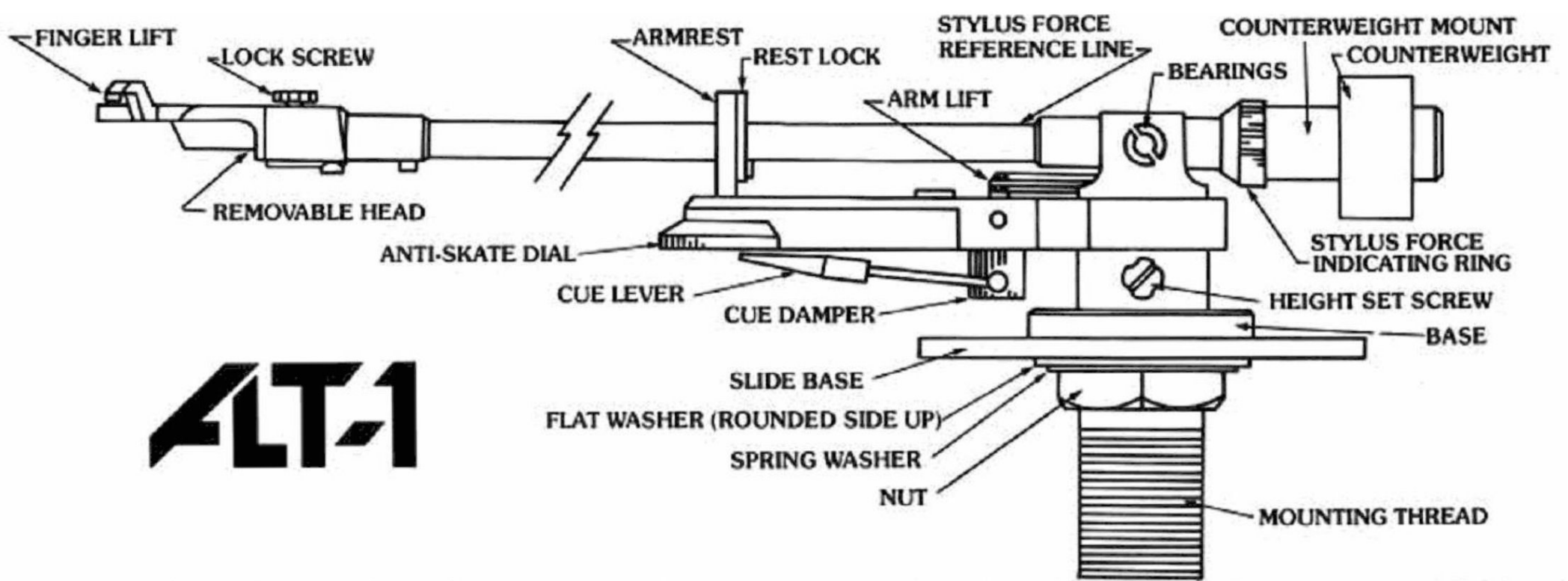

Audio Dynamics Corporation



ALTA1

SPECIFICATIONS

GEOMETRY

Tonearm Length: 9.33" (237mm) Pivot to stylus tip.
 Cartridge Offset Angle: 24.6°
 Stylus Tip Overhang: .760" (19mm).
 Zero Tracking Angle Error at 2.7" and 5.06"
 (69 and 129mm)
 Maximum Tracking Angle Error: 1.25° at 2.38",
 3.69" and 5.75" radius. (60, 94 and 146mm.)

TONEARM LIFTER

Cue: Lever control.
 Damping: Viscous oil damped.
 Height Adjustment: Lifter is factory adjusted.

BALANCE

Cartridge Weight Range: 4 to 11 grams.
 Stylus Force Range: Calibrated 0 to 4 in 1/4 g steps.
 Bearings Type: Stainless steel ball bearings.
 Effective Arm Mass: 7.0 grams with counterweight
 set for ADC XLM cartridge.
 Anti-Skate Range: 0 to 4 grams.

CAPACITANCE

Arm Wiring: 18 pF per channel
 Lead Wires (Stereo): 220 pF per channel (normal).
 Lead Wires (CD-4): 100 pF per channel (available
 accessory).

ALTA1

ACCESSORIES

ALT-1

500 gram STABILIZER BASE ASL-1

This Stabilizer Base provides additional mass to help stabilize lightweight turntable bases, thus establishing a firm foundation for mounting the ALT-1 arm. The ASL-1 replaces the nut normally used to secure the ALT-1 arm to the turntable base.

CD-4 LEAD WIRES CD4W

These special lead wires are required for discrete CD-4 systems. They are also useful to audiophiles whose preamplifiers have a large input capacitance.

ALT-1 SPARE HEADS LMH-1

This removable head allows the audiophile whose tastes require alternative phono cartridges to make pre-mounted changes in seconds.

OFF-SET ANGLE FOR ALT-1

Write "OFF-SET" on your warranty card when you return your card to ADC. In turn, we will send you a booklet on the OFF-SET ANGLE of tonearms.

INSTRUCTIONS

1. Locating the Tonearm Position on Your Turntable

Place the TEMPLATE I hole 'B' over the spindle of your turntable, see figure 1. Rotate the template until side 'C' is parallel to your turntable edge as shown. The round edge 'R' should, at this time, be within your turntable cover limits. If it is not, move the template until the curved edge is just within the turntable cover. With the template held in this position, mark center of hole 'A' as the location for centering TEMPLATE II.

- Place the "Reference Center" of your SLIDE-BASE CUT-OUT TEMPLATE II exactly on the center you have located for hole 'A'.
- Turn TEMPLATE II around its' center until the 2½" hole sides are parallel to the turntable panel side.
- While keeping the centers together, mark the location of the 2½" × ¾" opening and the location of the four screw start holes on your turntable panel.

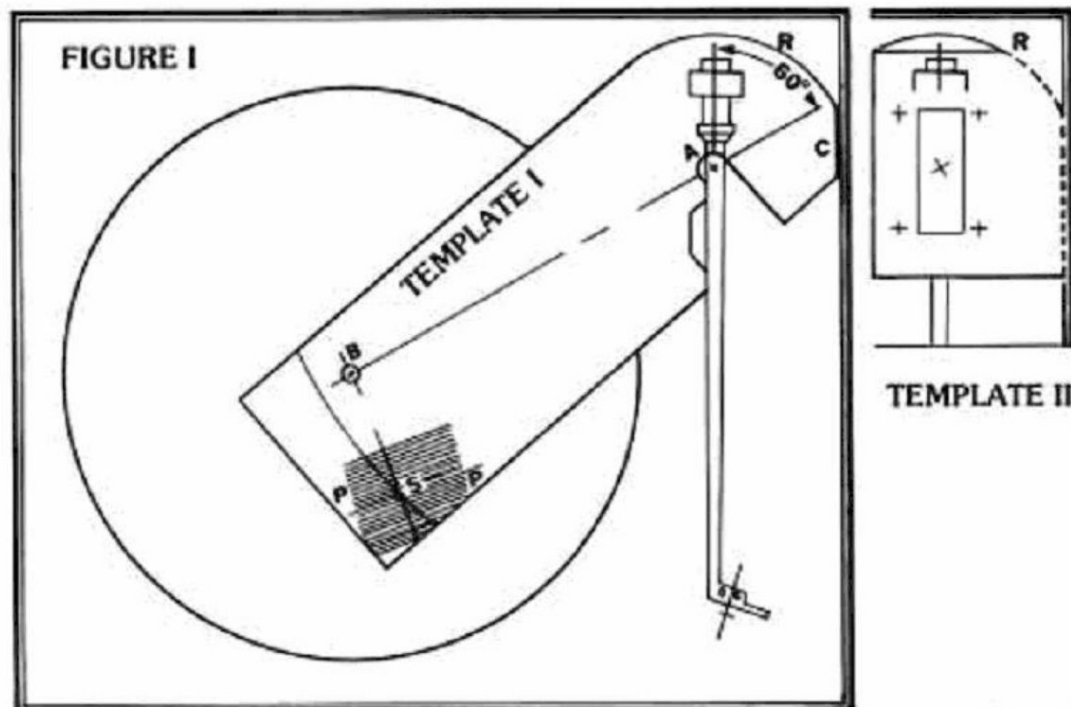
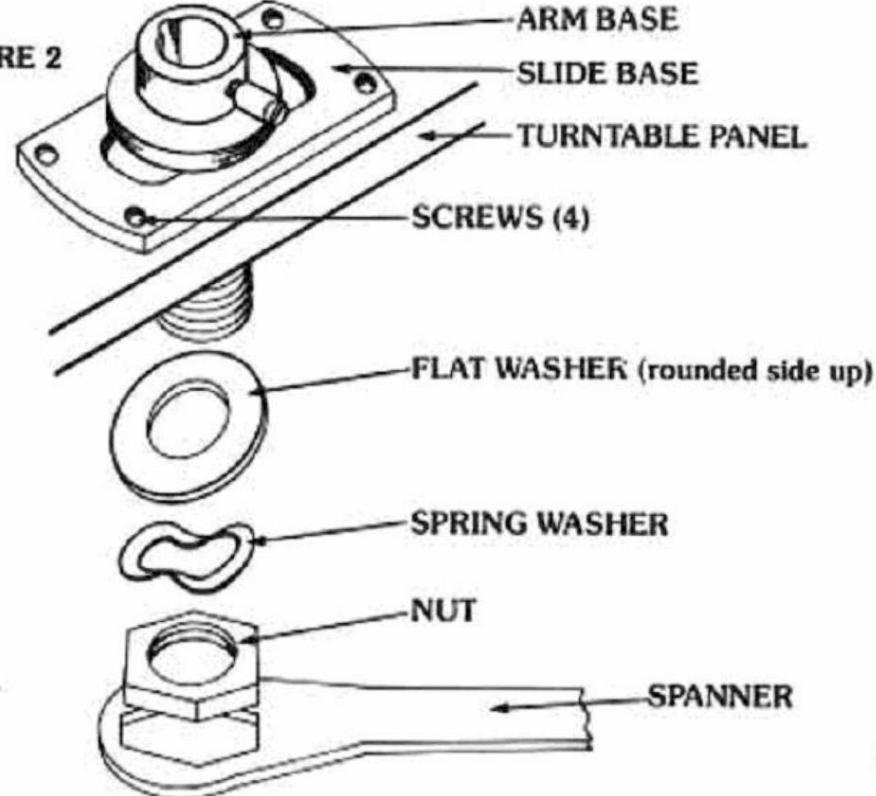

FIGURE 2



2. Mounting Your Tonearm

- Cut out the opening in your turntable panel and make four small holes to start the screws; use a punch or very small drill.
- Mount your Slide Base with the four screws provided. (Soap may be used on screws for easy entry into turntable panel).
- Attach the base with the arrangement of parts shown in figure 2. Very lightly, tighten the nut.

3. Mounting Your Tonearm, cont'd.

See figure 3. Insert the *tonearm shaft* into the *arm base* aligning the groove of the shaft and the set screw of the base. Place hole 'B' of TEMPLATE I over the *turntable spindle* and move the *arm base* in the slot of the *slide base* until hole 'A' of TEMPLATE I fits onto the *tonearm shaft* as shown in figure 3. With the tonearm locked in the arm rest, rotate the base in its mounting hole so that the arm direction aligns with the 60° line shown on the TEMPLATE. This will assure best operation of the cueing lift. With the arm in this position, tighten the base mounting nut firmly, see figure 2, with the spanner (wrench) supplied.

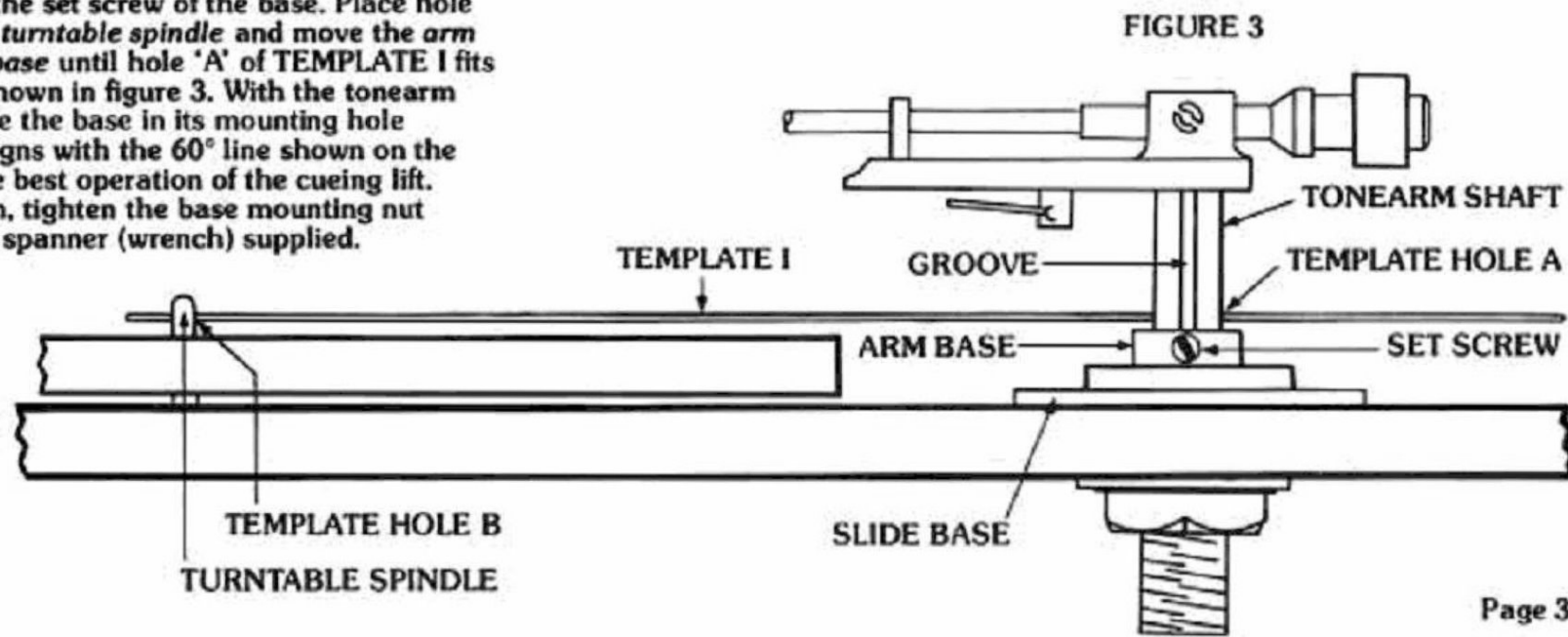

4. How To Mount Your Cartridge

See figure 4. Hold the cartridge with its stylus tip approximately in the 3½mm (.139") position shown and lightly tighten the cartridge mounting screws. Connect the lead wire terminal clips to the terminals of the cartridge with colors corresponding as follows:

LS	White	LG	Blue
RS	Red	RG	Green

Insert the head with mounted cartridge into the tip of the arm aligning the head groove with the lock screw. Loosen the lock screw slightly if required. With the head inserted all the way, carefully tighten the lock screw securely, but not too much.

Move the arm to place the stylus tip over point 'S' on TEMPLATE I. Gently move the cartridge so that the exact alignment of the stylus tip and point 'S' is obtained with the cartridge body parallel with the 'P' set of lines. Tighten the screws to secure the cartridge in this position. Note that this procedure does not necessarily place the cartridge square to the arm head.

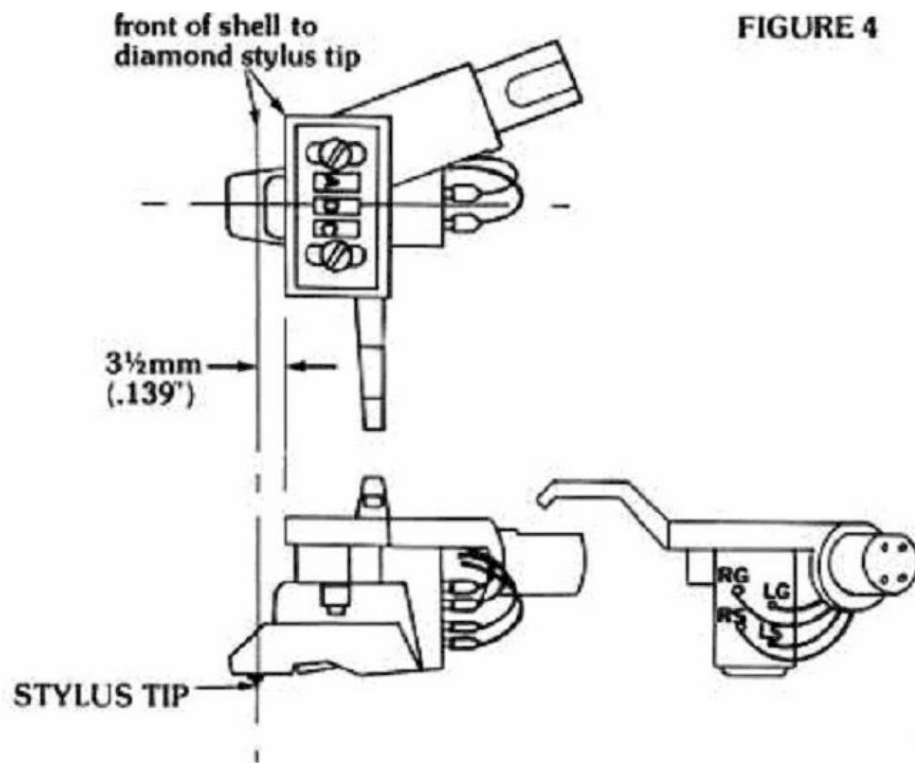

FIGURE 4

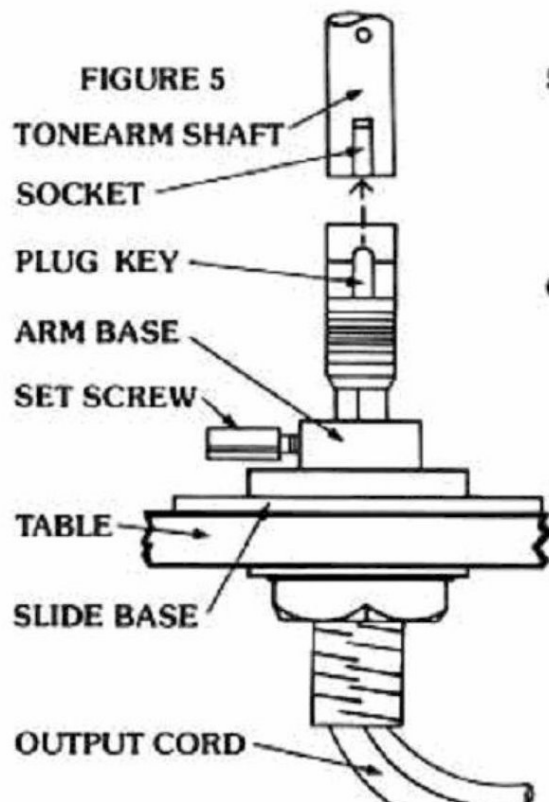

FIGURE 5

5. How to Connect Output Cord

At this time, remove the template.

Raise the tonearm shaft out of the base. Put the output cord through the tonearm base hole, see figure 5. Align the plug key with the socket slot and press it home. Reinsert the arm shaft into the arm base. With the output cord connected align the groove with the set screw and lightly tighten the set screw.

6. Adjustment of Arm Height

Adjust the arm height by raising or lowering the tonearm shaft in its base until the arm is visually parallel to the record surface with the stylus tip resting on a record, see figure 6. Tighten the tonearm base set screw to secure the arm at this height.

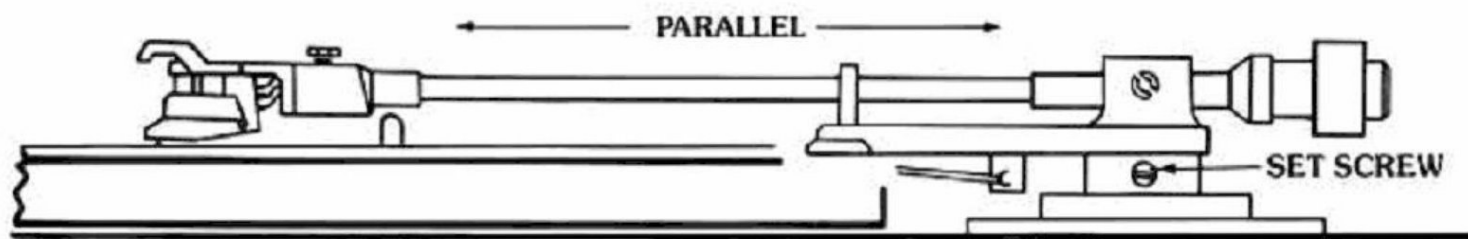

FIGURE 6

7. Balance Adjustment and Stylus Force Adjustment

Turn the anti-skating dial to OFF as shown in figure 7. Remove a separate type stylus guard from the cartridge, or lift a flip-down type stylus guard while making your stylus force adjustment.

Carefully slide the counterweight onto the rear of the tonearm. Turn the counterweight mount to move it closest to the arm pivot bearings, and then turn back out one full turn.

Move the balance counterweight back and forth lightly until the arm is balanced with your stylus tip just off the record surface.

Set the stylus force indicating ring to 0 (zero) at the indicator line.

Turn the mount, the counterweight and the indicator ring together as a unit to put your required stylus force at the indicator line. (See your cartridge specifications for your correct stylus force.)

8. Adjustment of the Anti-Skating

The most suitable value is obtained when the indication of the anti-skating dial is matched to the stylus force value.

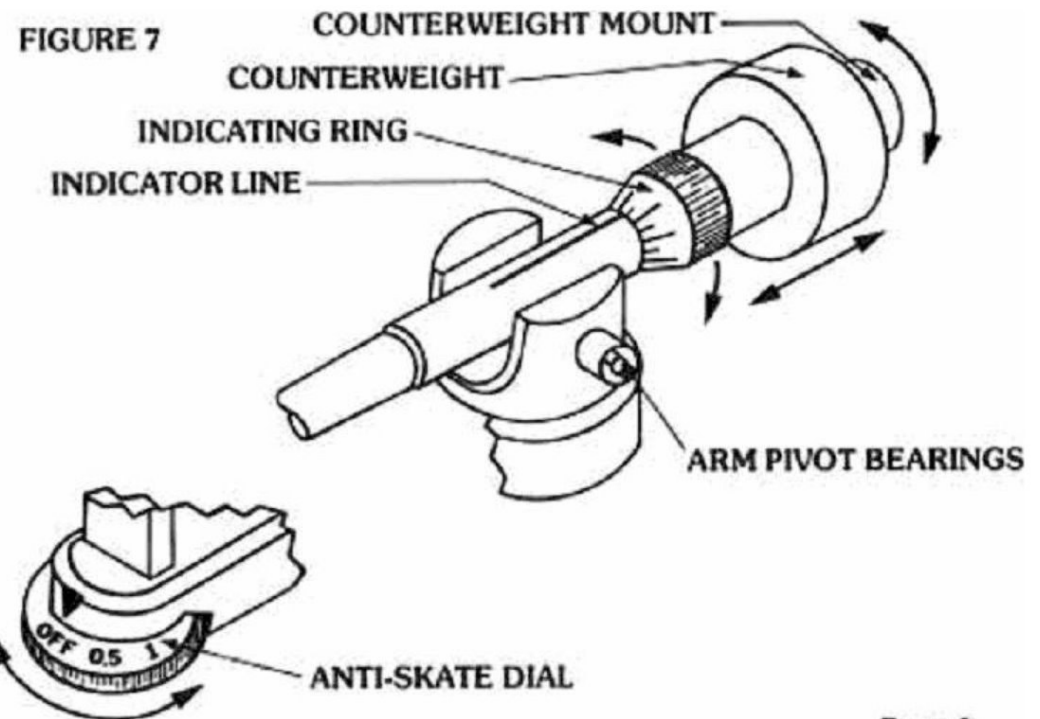

ALTERNATE MOUNTING INSTRUCTIONS

using a single round hole to mount the arm-base without use of the slide-base

1. Locating the Tonearm Position on Your Turntable

Place the TEMPLATE I hole 'B' over the spindle of your turntable, see figure 8.

Rotate the template until side 'C' is parallel to your turntable edge as shown. The round edge 'R' should, at this time, be within your turntable cover limits. If it is not, move the template until the curved edge is just within the turntable cover. With the template held in this position, mark center of hole 'A' as the location for drilling to mount your tonearm.

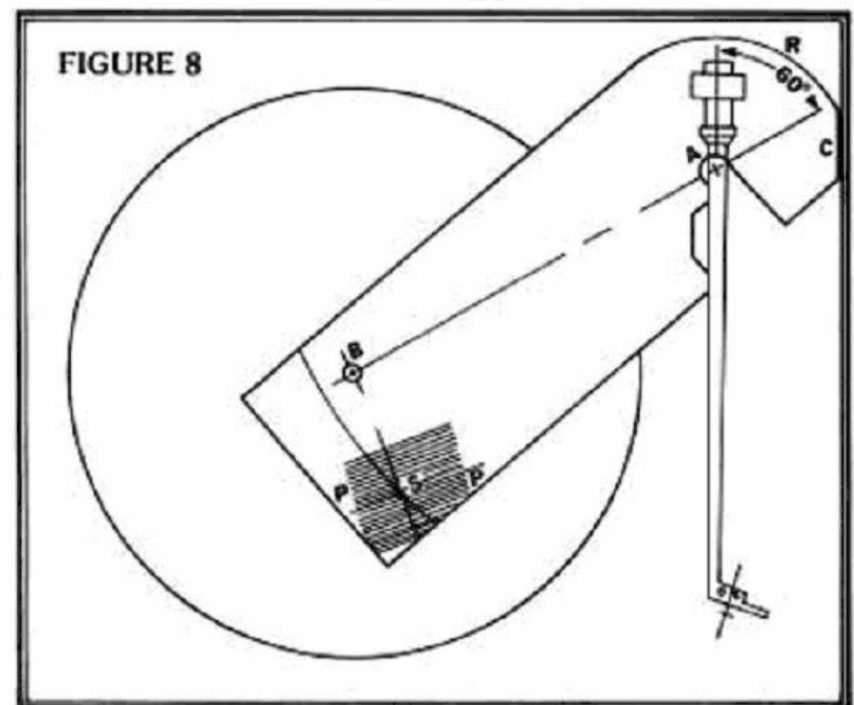

2. Mounting Your Tonearm

Make a 25mm (one inch) hole at the exact location of template hole 'A' per the instructions of paragraph 1. Attach the base with the arrangement of parts shown in figure 2, page 2. Very lightly tighten the nut.

Refer to figure 3, page 3. Insert the *tonearm shaft* into the *arm base* aligning the groove of the shaft and the set screw of the base. Place hole 'B' of TEMPLATE I over the turntable spindle and move the arm base in the 1" mounting hole until hole 'A' of TEMPLATE I fits onto the tonearm shaft as shown in figure 3.

3. How To Mount Your Cartridge

See figure 4. Hold the cartridge with its stylus tip approximately in the 3½mm (.139") position shown and lightly tighten the cartridge mounting screws. Connect the lead wire terminal clips to the terminals of the cartridge with colors corresponding as follows:

LS	White	LG	Blue
RS	Red	RG	Green

Insert the head with mounted cartridge into the tip of the arm aligning the head groove with the lock screw. Loosen the lock

screw slightly if required. With the head inserted all the way, carefully tighten the lock screw securely, but not too much.

Move the arm to place the stylus tip over point 'S' on TEMPLATE I. Gently move the cartridge so that the exact alignment of the stylus tip and point 'S' is obtained with the cartridge body parallel with the 'P' set of lines. Tighten the screws to secure the cartridge in this position. Note that this procedure does not necessarily place the cartridge square to the arm head.

4. How to Connect Output Cord

At this time, remove TEMPLATE I.

Put the output cable through the tonearm base hole, see figure 5 on page 5. Align the plug key with the socket slot and press it home. Reinsert the arm shaft connected into the base with the output cable aligning the groove with the set screw and lightly tighten the set screw.

5. Adjustment of Arm Height

Adjust the arm height by raising or lowering the tonearm shaft in its base until the arm is visually parallel with the stylus tip resting on a record, see figure 6 on page 5. Tighten the tonearm base set screw to secure the arm at this height.

Page 8

6. Balance Adjustment and Stylus Force Adjustment

Turn the anti-skating dial to OFF as shown in figure 7. Remove a separate type stylus guard from the cartridge, or lift a flip-down type stylus guard while making your stylus force adjustment.

Carefully slide the counterweight onto the rear of the tonearm.

Turn the counterweight mount to move it closest to the arm pivot bearings, and then turn back out one full turn.

Move the balance counterweight back and forth lightly until the arm is balanced with your stylus tip just off the record surface.

Set the stylus force indicating ring to 0 (zero) at the indicator line.

Turn the mount, the counterweight and the indicator ring together as a unit to put your required stylus force at the indicator line. (See your cartridge specifications for your correct stylus force.)

7. Adjustment of the Anti-Skating

The most suitable value is obtained when the indication of the anti-skating dial is matched to the stylus force value.

LIMITED WARRANTY

Your ADC tonearm is warranted to meet manufacturer's specifications for at least one year from the date of purchase. If for any reason, other than outright abuse, your ADC tonearm does not perform properly, return it to our Customer Service Manager at the address on the back cover and we will repair or replace it free of charge. Be sure to include proof of purchase date.

If you should have questions concerning your tonearm or the warranty, please feel free to contact us at the following toll free telephone number. (800) 243-9544, Connecticut residents dial 355-2671. We will be happy to assist you.

TEMPLATE II INSTRUCTIONS

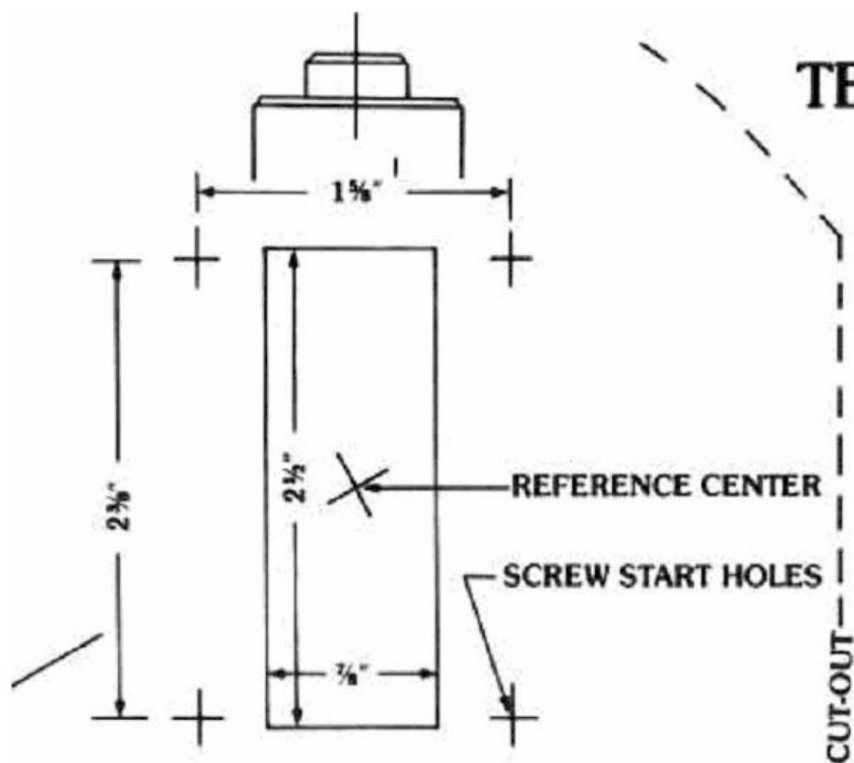

**TEMPLATE II
SLIDE BASE MOUNTING**

MOUNTING SCREWS (4)

SLIDE BASE ASB-1 mk II

REFERENCE CENTER

SCREW START HOLES

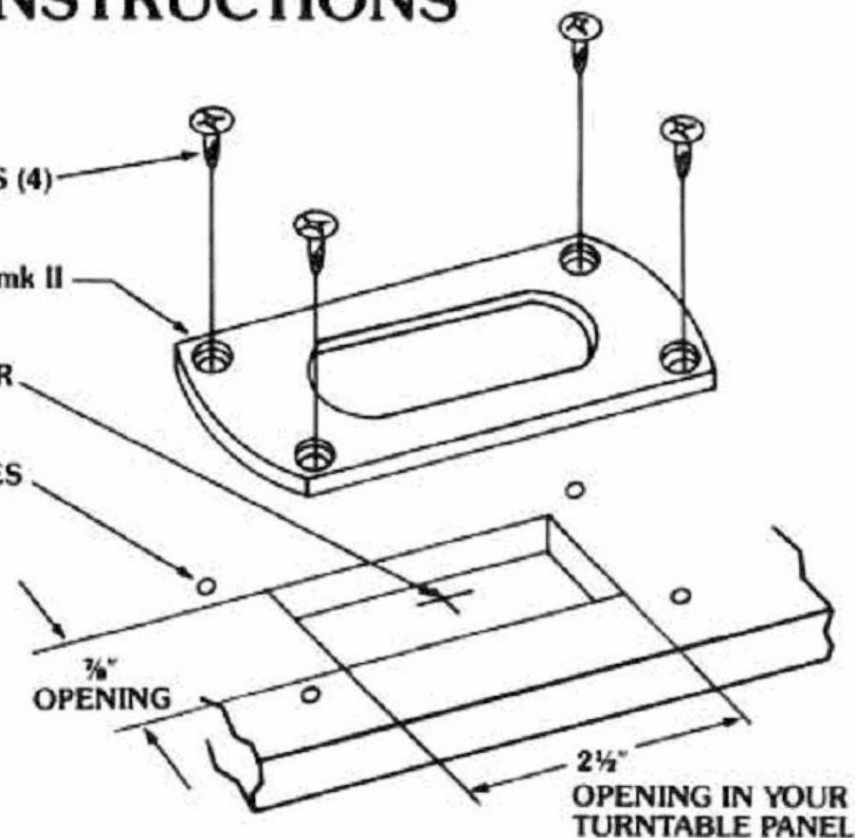

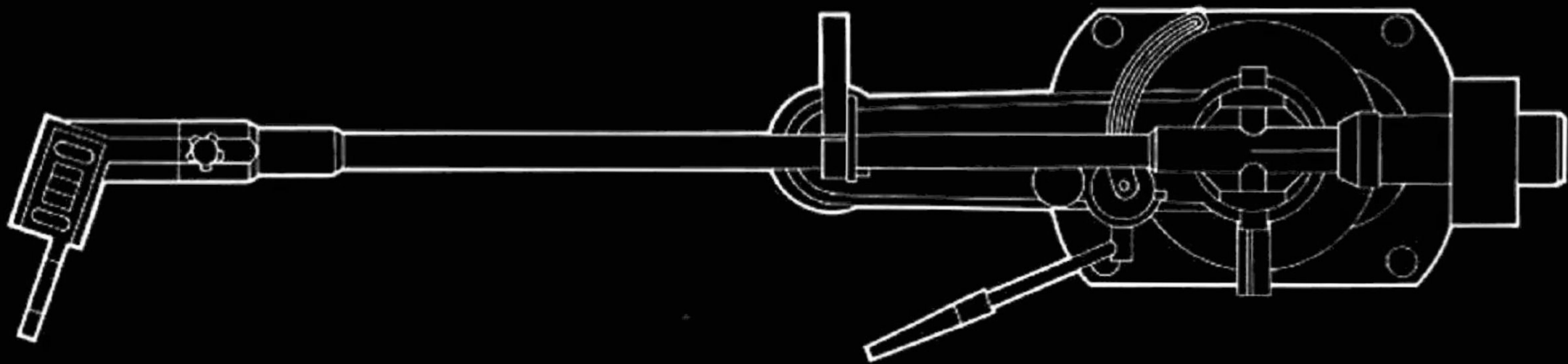

A D C

AUDIO DYNAMICS CORPORATION PICKETT DISTRICT ROAD NEW MILFORD, CONN. 06776 A BSR COMPANY