

# Pritchard Pickup System

models ADC-85 & 40

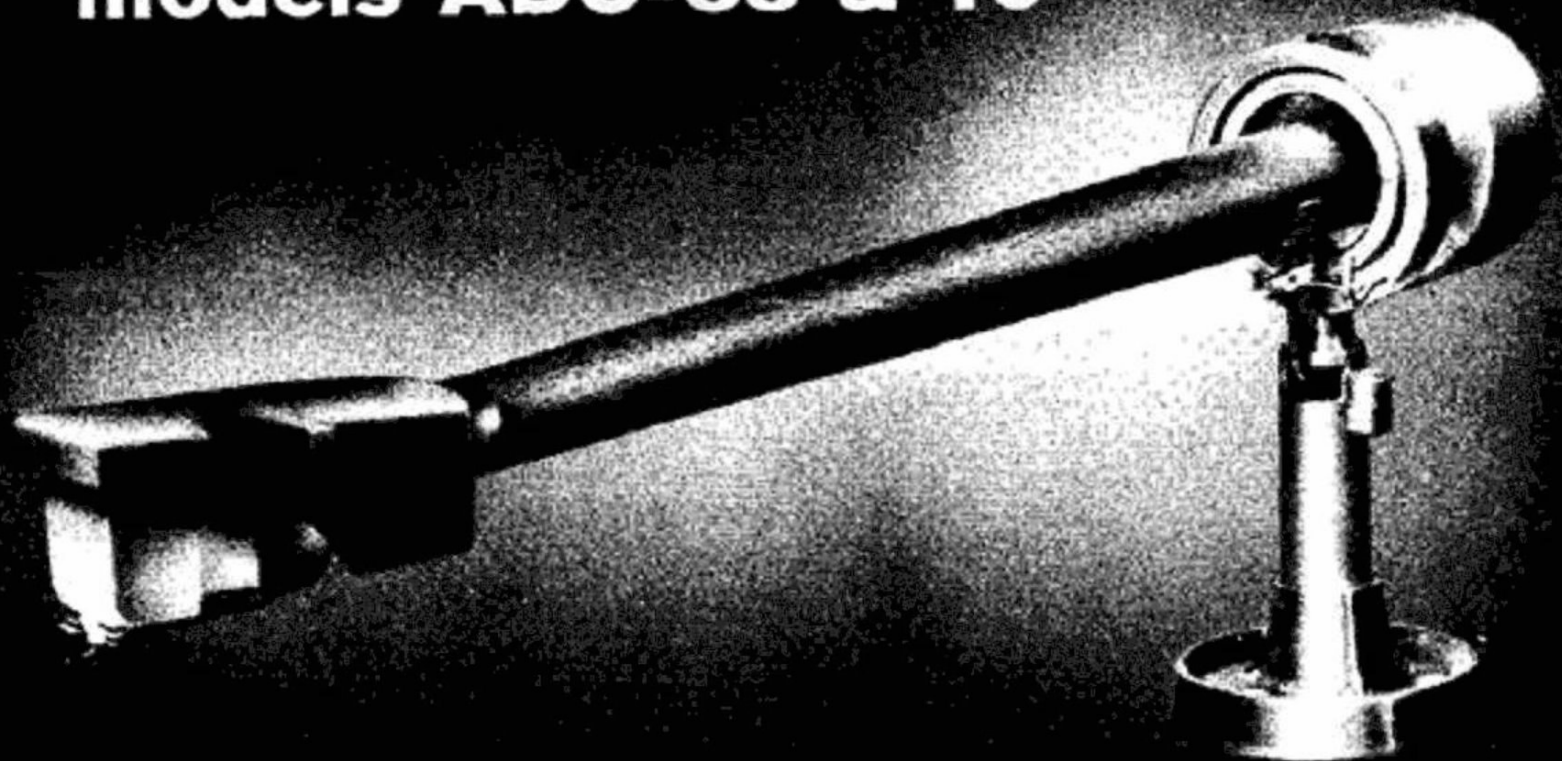

**Instructions  
for use**



**AUDIO DYNAMICS CORPORATION**

1677 CODY AVENUE, RIDGEWOOD 27, NEW YORK

# General Description

The Pritchard Pickup System consists of the superb ADC-1 cartridge combined with an entirely new tone arm especially designed to provide the finest possible pickup performance.

The arm has a very low moment of inertia necessary for stable tracking at  $\frac{3}{4}$  gram. To stabilize the centripetal force created by friction between the stylus and the record, a side thrust compensator is provided. This results in an even pressure on both groove walls—essential for distortion-free stereo reproduction. Precision, single ball bearings in gimbals reduce vertical and lateral friction to a negligible quantity. Drag is further reduced by a unique wire guide so arranged that the ultra-fine lead wires twist along their own axis.

The body of the arm is accurately machined from specially treated walnut which suppresses extraneous resonances and insures that the arm adds no "color" to the reproduction.

A plug-in shell is provided for convenient removal of the cartridge and additional shells may be used to accommodate other high compliance cartridges.

The arm-cartridge combination is balanced in all planes making it very insensitive to external shock. No leveling of the turntable is required; in fact perfect tracking may be obtained with the turntable tilted as much as  $30^\circ$  to the horizontal.

The geometry of the arm is arranged to give minimum tracking distortion and **not** minimum tracking error. (The reasoning behind this is based on the fact that a given tracking error in the inner record grooves produces more distortion than the same degree of tracking error in the outer grooves.)

A unique integrated arm rest is incorporated in the tone arm, eliminating the need for separate mounting of an arm rest.

## SPECIFICATIONS

<b>Arm length</b>	10 $\frac{5}{8}$ " overall
<b>Pivot to stylus tip</b>	9"
<b>Rear overhang</b>	1 $\frac{3}{4}$ "
<b>Fundamental resonance</b>	6 cycles/sec. (with ADC-1 cartridge)
<b>System tracks at <math>\frac{3}{4}</math> gram.</b>	
<b>Tone arm accommodates other cartridges.</b>	

The system comes completely assembled and wired, and is provided with a cable assembly ready to plug into amplifier.

# Installation of Arm

Your Pritchard Pickup System is a precision instrument built to the highest engineering standards. It should, therefore, be treated with every reasonable care.

It is suggested that the plug-in shell be removed during installation in order to protect the cartridge and stylus.

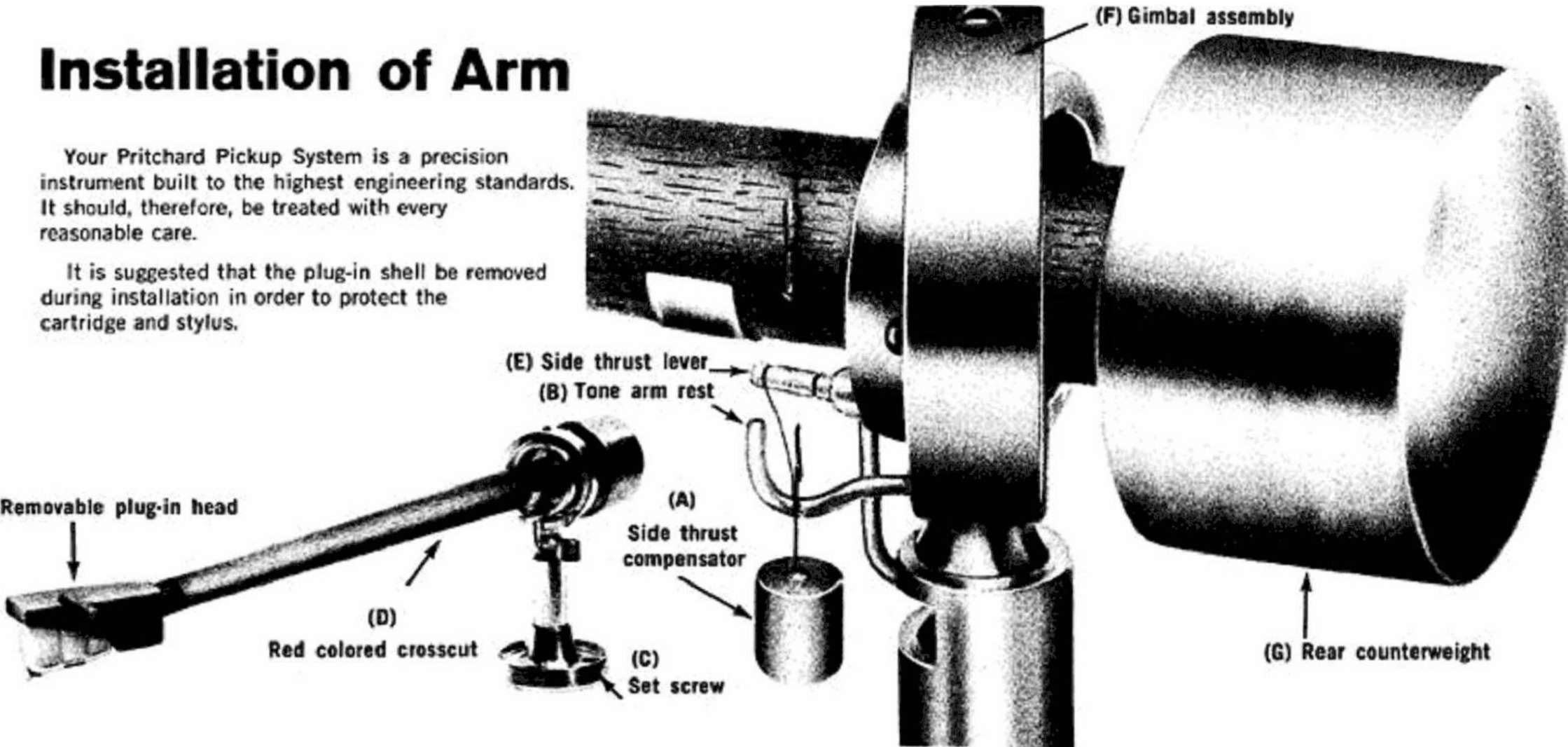

## Mounting The Arm

The arm may be mounted in any convenient position on the baseboard. For optimum tracking the stylus should overhang the center of the turntable by .7".

You may use the inner box on which the arm is mounted as a template for location of the pivot post hole by inverting the box, placing hole "B" over the turntable spindle and inserting a pencil or other marking instrument in hole "A" right through the thickness of the box.

The pivot post position is located in the arc described by the path of the pencil. Note, however, that the point of the arc chosen to locate the exact position of the pivot post should be such that the arm itself is free to swing from the "rest" position to the center of the record.

After locating the pivot post center, drill a 9/16" or 5/8" hole at this point. Center the base accurately over the hole and mark the centers of the three mounting screw holes. If a metal baseboard is used, three holes, 1/8" in diameter, must be drilled. In case of a wood

baseboard, three woodscrew starting holes will be necessary. Using the machine screws, nuts and washers or woodscrews provided, secure the base to the baseboard. (Do not tighten beyond point where screw head meets gromet.) The base will be firmly secured while still allowing a degree of flexibility. Gromets should not be compressed.

## 2. Positioning The Tone Arm

Adjust height of tone arm by slackening the set screw (C) in base and moving pivot post up or down until the bottom of the wooden tone arm is parallel to the surface of a record placed on the turntable.

Be sure that the gimbal assembly (F) is turned so that the arm is free to move over the playing area of the record and yet drop into the arm rest at a convenient position alongside the turntable.

## 3. Adjusting Tracking Pressure

The correct tracking pressure (3/4 gram for the ADC-1) is obtained by adjusting the rear-counterweight, (G), (flexible in its mounting) clockwise or counter clockwise until the desired pressure is achieved.

To measure tracking pressure, any accurate gram gauge calibrated from 2 to 8 grams may be used. First rest the stylus anywhere on the record. Then, place the gauge under the arm at a position indicated by the red colored crosscut (D). Lift the arm with the gauge. When the stylus just comes clear of the record surface, note the reading of the gauge and divide this reading by four, e.g., a gauge reading of 3 grams indicates a pressure of  $\frac{3}{4}$  gram; a reading of 6 grams indicates a pressure of  $1\frac{1}{2}$  grams, etc. If a sufficiently accurate gram gauge that measures below 1 gram is available, you may, of course, measure tracking pressure at the stylus tip in the conventional manner.

The thread attached to the side thrust compensator (A) should be draped over the tone arm rest (B) as shown in the illustration. For tracking pressures of 1 gram or less, the thread attached to side thrust lever (E) should be looped around the groove nearest to the pivot. For higher pressures, the outer groove should be used.

## Electrical

A cable assembly is supplied in order to conveniently connect the tone arm leads to the amplifier. The five-pin plug should be inserted in the socket at the base of the pivot post. The phono plug attached to the grey cable should be inserted in the right channel amplifier input socket and that having the black cable in the left channel socket. The black ground lead should be connected to the amplifier ground.

## Cartridge Mounting

In those cases where the arm is supplied without a cartridge, or it is desired to mount a different cartridge in the shell, the mounting hardware supplied may be used. The connections for the shell leads are as follows:

**Right Channel Hot — Red**  
**Right Channel Ground — Green**  
**Left Channel Hot — Yellow**  
**Left Channel Ground — Black**

If you follow the foregoing instructions carefully the Pritchard Pickup System will perform perfectly.

## Do

- Remove the plug-in shell before installation
- Handle the arm with care
- Check the gimbal assembly before tightening set screw to be sure arm can move from the "rest" position to the center of the record
- Return the enclosed warranty card

## Don't

- Apply lubricating oil
- Transport arm without first removing plug-in-head
- Clean treated wooden tone arm with abrasive cleaning fluids or materials

## GUARANTEE

Every Pritchard Pickup System, cartridge and stylus is precision-crafted of the finest materials. These are carefully tested at Audio Dynamics laboratory. The ADC-1 stereo cartridge is guaranteed forever and the stylus assembly guaranteed for one year against defects in materials and workmanship. The arm alone (ADC-40) is also

guaranteed for 1 year against defects in materials and workmanship.

If, under normal use, mechanical defects develop, and if the cartridge, stylus or arm have not been abused, misused or tampered with, we will be repaired or replaced without cost. We have only to return the attached warranty form within the 10 days of purchase. Unit should be sent to:



**AUDIO DYNAMICS**

Service Department **AUDIO DYNAMICS CORPORATION**  
1677 Cody Avenue, Ridgewood 27, New York