

---

# CONTAFLEX

---

## POCKET COMPANION

---

*by Joseph D. Cooper*

---

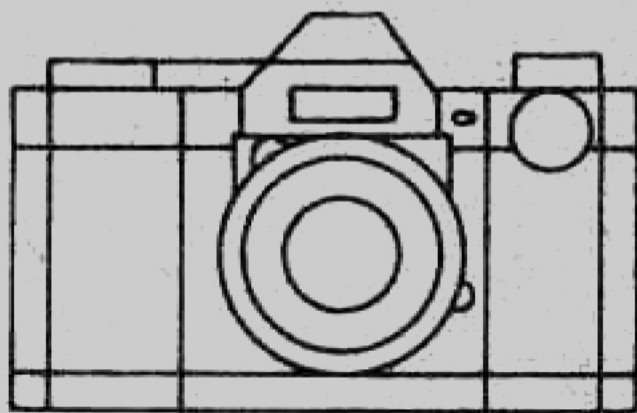

UNIVERSAL PHOTO BOOKS

**Copyright © 1962**  
**Universal Photo Books, Inc.**  
**New York 10, N. Y.**  
**ALL RIGHTS RESERVED**  
**Library of Congress Catalog Card No. 62-14417**  
**Manufactured in the United States of America**

# CONTENTS

## Chapter I The Contaflex System 5

### 1. Current Camera Models 5

1.1 Contaflex Super 5

1.2 Contaflex Prima 5

### 2. Earlier Camera Models 12

2.1 Contaflex Rapid 12

2.2 Contaflex IV 12

2.3 Contaflex III 12

2.4 Contaflex beta 12

2.5 Contaflex alpha 13

2.6 Contaflex II 13

2.7 Contaflex 1 13

### 3. Lens Systems 13

3.1 Converter lenses 13

3.2 Stereo attachment 14

3.3 Monocular attachment 15

3.4 Close-up attachments 15

### 4. Miscellaneous Accessories 16

4.1 Lenshoods 16

4.2 Eyesight correction lenses 17

4.3 Filters (see Chapter III)

4.4 Flash unit (see Chapter II)

4.5 Microscope attachment 17

4.6 Right angle finder 17

## Chapter II Operating the Camera 18

### 1. Loading and Unloading 18

1.1 Opening the camera 18

1.2 Loading film 19

1.3 Preparing first exposure 20

1.4 Unloading 23

1.5 Cassettes 23

### 2. Measuring the Light 24

2.1 Shutter speed ring 24

2.2 Automatic exposure control 25

2.3 Manual settings 26

2.4 Snapshot setting 26

3.	Picture-taking	27
3.1	Holding the camera	27
3.2	Shutter release	27
3.3	Rangefinder focusing	28
3.4	Ground-glass screen focusing	29
3.5	Depth-of-field scale	29
3.6	Delayed-action release	30
3.7	Interchanging lens components	31
4.	Flash Pictures	32
4.1	Flash equipment	32
4.2	Synchronization	32
5.	Contaflex Rapid	34
5.1	Similarities to Contaflex Super	34
5.2	Exposure value system	34
6.	Contaflex IV and III	35
7.	Contaflex beta and alpha	35
8.	Contaflex II and I	35
	<b>Chapter III FILMS AND FILTERS</b>	<b>36</b>
1.	Black-and-white Films	
1.1	Film characteristics	36
1.2	Slow films	37
1.3	Medium films	37
1.4	High-speed films	37
1.5	Ultra-high speed films	38
1.6	Special films	38
2.	Black and-white Filters	
2.1	Purposes of B-W filters	39
3.	Color Films	
3.1	Color film characteristics	41
3.2	Daylight reversal films	42
3.3	Tungsten reversal films	42
3.4	Flash reversal films	43
3.5	Negative color films	43
4.	Color Film Filters	
4.1	Conversion filters	43

## THE CONTAFLEX SYSTEM

### 1. Current Camera Models

#### 1.1 Contaflex Super

a) *Lens*: Zeiss Tessar  $f/2.8$ , 50mm standard lens, interchangeable front element.

b) *Shutter*: Synchro S-Compur, shutter speeds "B", 1 to 1/500 second. "X" and "M" synchronized flash contact. Built-in delayed-action device running for 8 seconds. Spring-loaded pre-selector diaphragm.

c) *Automatic exposure control*: Coupled to shutter. Control visible on camera body as well as through viewfinder.

d) *Rangefinder*: Both split-image rangefinder and fine-screen ring.

e) *Viewfinder*: Parallax-free image seen upright and laterally correct, almost natural size.

f) *Film advance*: Rapid-wind lever opens diaphragm, tensions shutter and advances film. Double exposure prevention.

g) *General features*: Frame counter, film type indicator, filter corrector, accessory shoe, semi-automatic film unlocking for rewinding, rewind knob with countersunk crank.

#### 1.2 Contaflex prima

a) *Lens*: Zeiss Ikon Pantar  $f/2.8$ , 45mm standard lens, front element interchangeable.

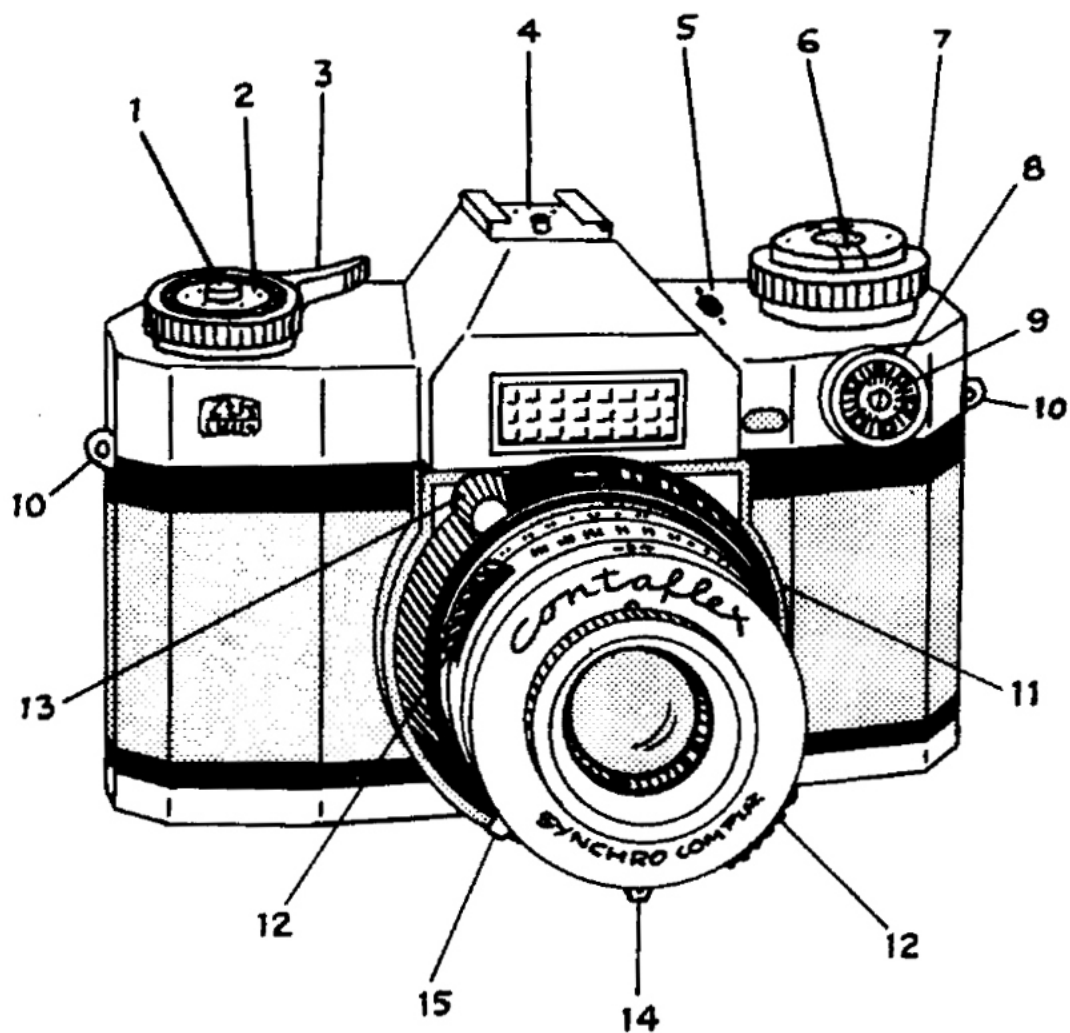

I-1.1. CONTAFLEX SUPER, FRONT VIEW

- |                                       |   |
|---------------------------------------|---|
| 1. Release knob                       | 9. Film speed setting                   |
| 2. Frame counter                      | 10. Eyelet straps for carrying case     |
| 3. Rapid wind lever                   | 11. Flash contact                       |
| 4. Accessory shoe                     | 12. Shutter speed setting knob          |
| 5. Window of exposure meter pointer   | 13. Focusing knob                       |
| 6. Rewind knob with countersunk crank | 14. Locking pawl for front lens element |
| 7. Film type indicator                | 15. Lock for flash lever                |
| 8. Light selector disk                |   |

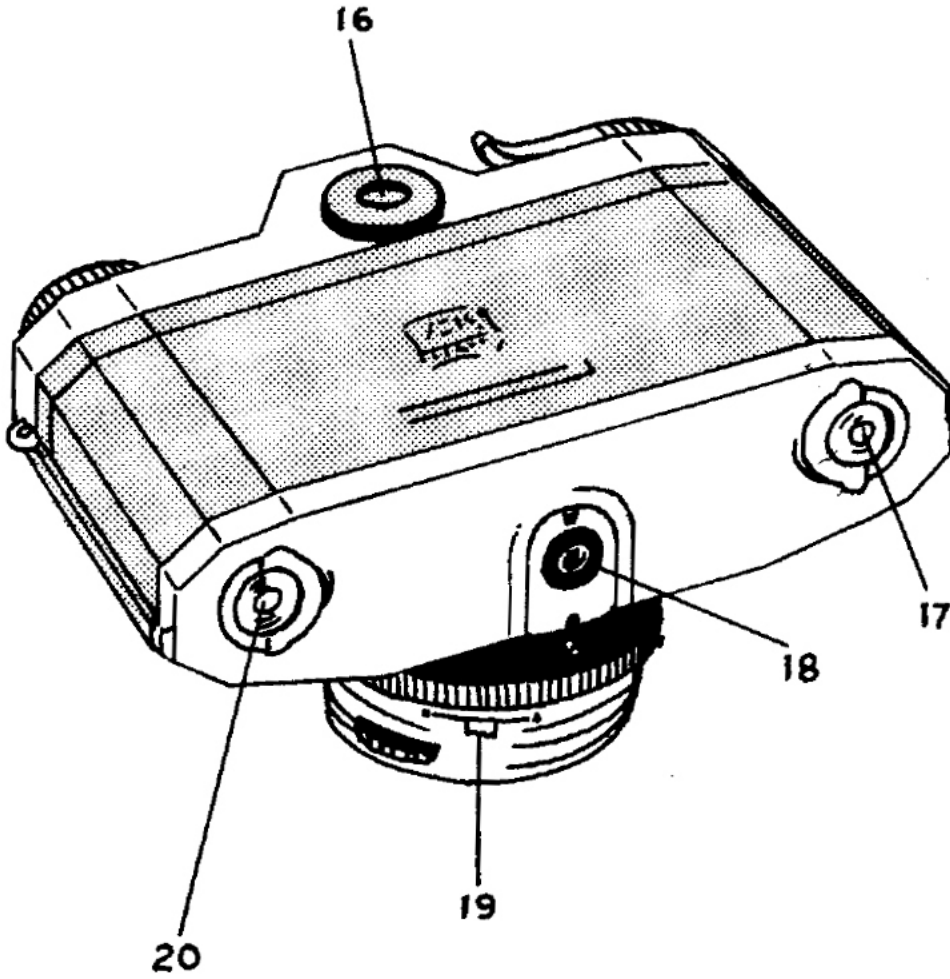

I-1.1. CONTAFLEX SUPER, BACK VIEW

- |                            |                           |
|----------------------------|---------------------------|
| 16. Viewfinder eyepiece    | 19. Setting lever for M-X |
| 17. Locking key for camera | flash contact and V       |
| back and film unlocking    | (self-timer)              |
| 18. Tripod bush            | 20. Locking key for back  |

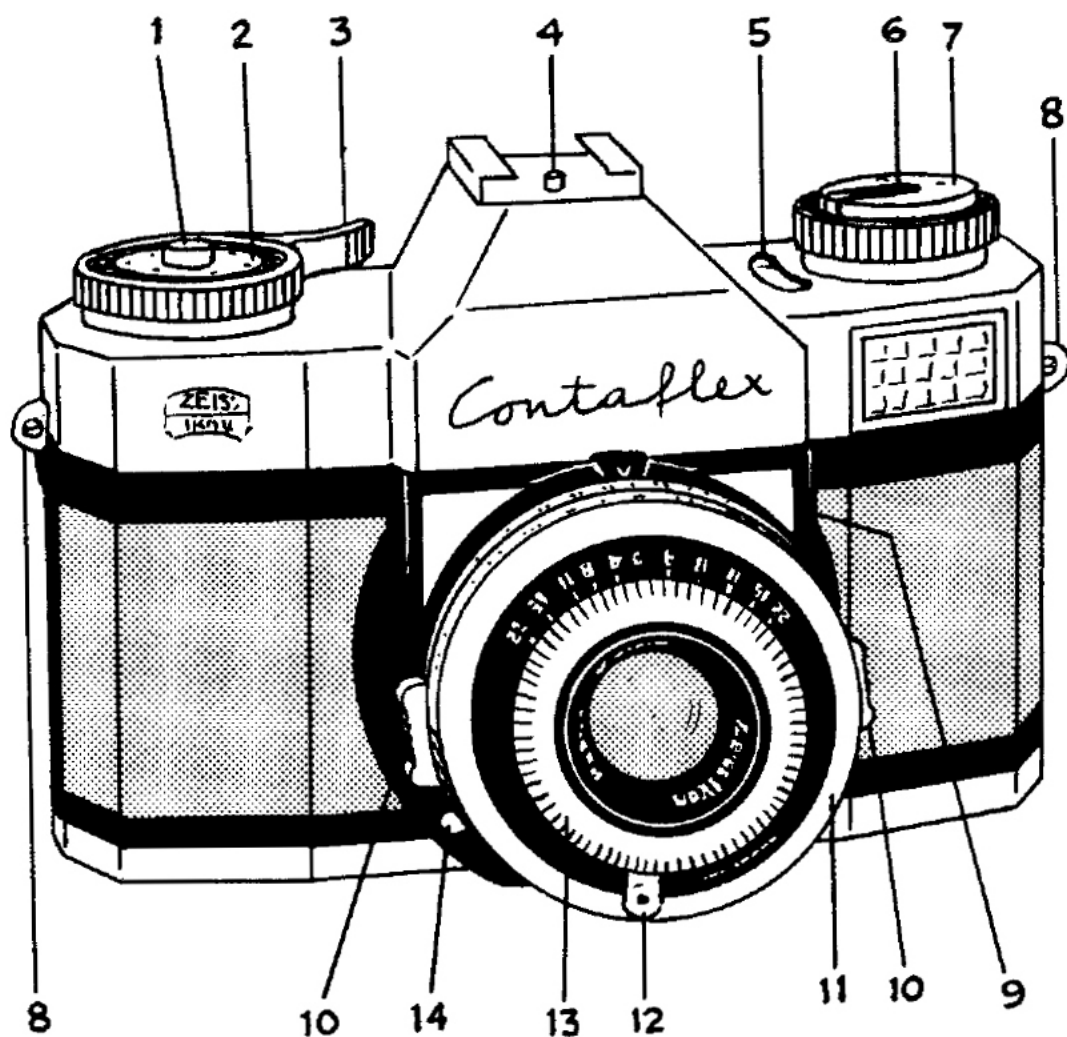

I-1.2. CONTAFLEX PRIMA, FRONT VIEW

- |                               |  |
|-------------------------------|--|
| 1. Release knob               | 10. Exposure setting disc                      |
| 2. Frame counter              | 11. Shutter speed/aperture rings               |
| 3. Rapid wind lever           | 12. Locking pawl for front lens element        |
| 4. Accessory shoe             | 13. Distance setting mark                      |
| 5. Exposure indicator         | 14. Lever for X, M, and V (self-timer) setting |
| 6. Rewind knob with crank     | 15. Viewfinder eyepiece                        |
| 7. Film type indicator        |  |
| 8. Eyelets for carrying strap |  |
| 9. Flash contact              |  |

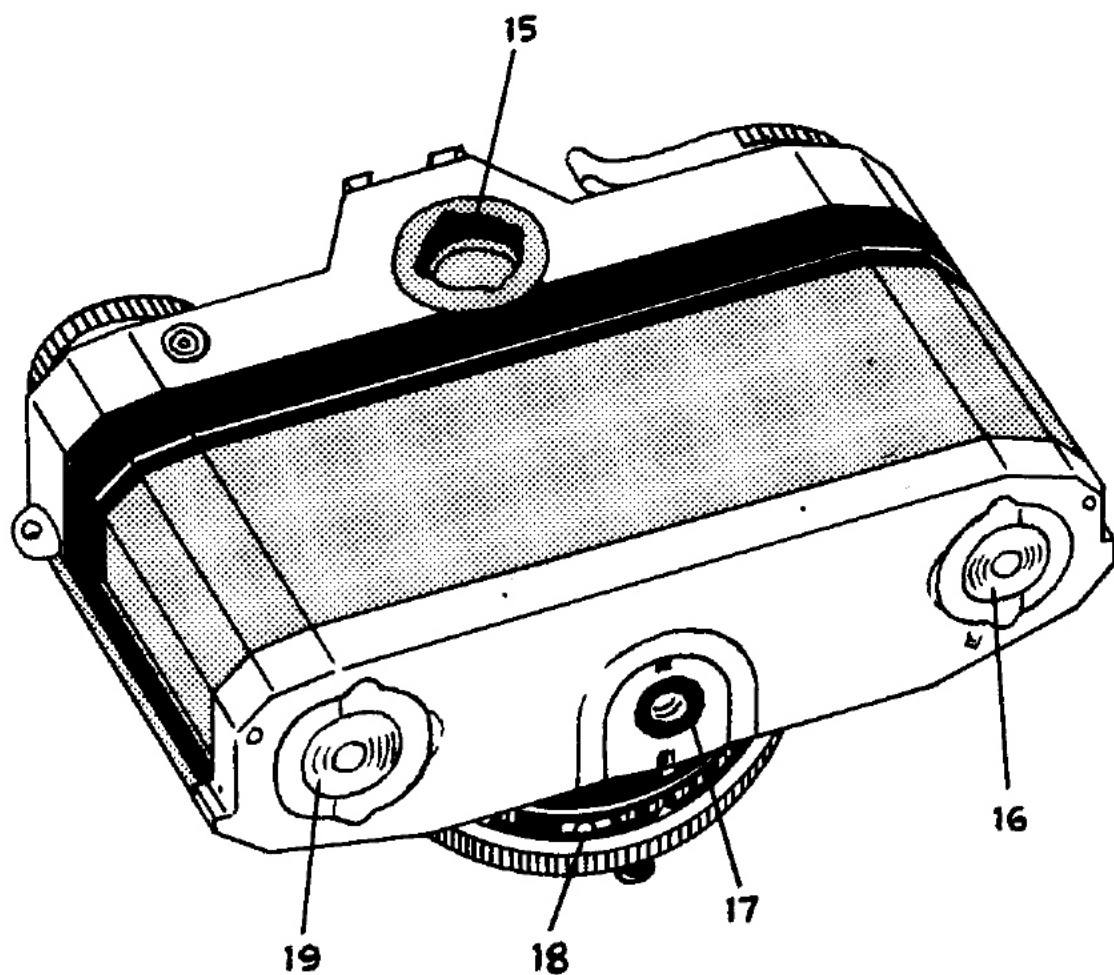

I-1.2. CONTAFLEX PRIMA, BACK VIEW

- |   |                              |
|---|------------------------------|
| 16. Camera back locking key and film rewind unlocking catch | 17. Tripod bush              |
|   | 18. Film speed setting scale |
|   | 19. Camera back locking key  |

*DEPTH-OF-FIELD TABLE FOR THE CONTAFLEX WITH TESSAR f/2.8/50 mm.*

Dis- tance	Aperture f/2.8	Aperture f/4	Aperture f/5.6	Aperture f/8	Aperture f/11	Aperture f/16	Aperture f/22
∞	64'4" - ∞	45'1" - ∞	32'4" - ∞	22'9" - ∞	16'8" - ∞	11'6½" - ∞	8'6" - ∞
20'	15'4" - 28'9"	14' - 35'6"	12'6" - 51'7"	10'8¾" - 162'5"	9'2" - ∞	7'4½" - ∞	5'11¾" - ∞
10'	8'8½" - 11'9"	8'3" - 12'8"	7'8¾" - 14'3"	7'½" - 17'5"	5'¼" - 11'8"	5'5½" - 7'4"	4'8" - ∞
7'	6'4¼" - 7'9½"	6'1½" - 8'2¼"	5'10" - 8'9½"	5'5¼" - 9'10½"	5'¼" - 11'8"	4'5½" - 17'	3'11¼" - 37'4"
5'	4'8" - 5'4½"	4'6½" - 5'6¾"	4'4¾" - 5'9¾"	4'2" - 6'3"	3'11¼" - 6'11"	3'7" - 8'5"	3'3" - 11'5"
4'	3'9½" - 4'2¾"	3'8½" - 4'4"	3'7¼" - 4'6"	3'5½" - 4'9"	3'3½" - 5'1¼"	3'¾" - 5'10"	2'9¾" - 7'1"
3'	2'10¾" - 3'1½"	2'10¾" - 3'2"	2'9½" - 3'3"	2'8½" - 3'4½"	2'7¼" - 3'6½"	2'5½" - 3'10½"	2'3¾" - 4'4¼"
2.5'	2'5" - 2'7"	2'4¾" - 2'7¼"	2'4¼" - 2'8"	2'3½" - 2'9"	2'2¾" - 2'10¼"	2'1½" - 3'½"	2'½" - 3'3¾"

The depth of field is measured from the film plane.

*DEPTH-OF-FIELD TABLE FOR THE CONTAFLEX WITH PANTAR f/2.8/45 mm.*

Distance	APERTURE									
	f/2.8	f/4	f/5.6	f/8	f/11	f/16	f/22			
∞	47'8"-∞	33'2"-∞	23'10"-∞	16'9"-∞	12'3"-∞	8'4"-∞	6'2"-∞			
30'	18'6"-80'	15'11"-28'1"	13'5"-∞	10'10"-∞	8'9"-∞	6'8"-∞	5'2"-∞			
15'	11'6"-21'8"	10'5"-26'9"	9'4"-39'2"	8'-129'6"	6'10"-∞	5'6"-∞	4'6"-∞			
9'	7'7"-11'1"	7'1"-12'3"	6'6"-14'4"	5'10"-18'10"	5'2"-32'8"	4'4"-63'2"	3'4"-∞			
6'	5'4"-6'9"	5'2"-7'2"	4'10"-7'10"	4'6"-9'1"	4'2"-11'3"	3'8"-18'10"	3'2"-100'7"			
5'	4'7"-5'6"	4'5"-5'10"	4'2"-6'2"	3'11"-6'11"	3'8"-8'1"	3'3"-11'4"	2'11"-22'1"			
4'	3'9"-4'4"	3'7"-4'6"	3'6"-4'9"	3'3"-5'1"	3'1"-5'8"	2'10"-7'1"	2'8"-10'1"			

The smaller the aperture, the longer must be the exposure. The lens should, therefore, be stopped down only as much as is necessary to obtain the required depth of field, in order to avoid camera shake and blurred pictures due to your own motion or that of the subject.

b) *Shutter*: Prontor Reflex. Shutter speeds "B", 1 to 1/300 second. "X" and "M" synchronized flash contacts. Built-in delayed-action device running for 8 seconds. Pre-set spring diaphragm.

c) *Exposure control*: Coupled to shutter setting, indicator on camera body only.

d) *Other details*: Same as Contaflex Super.

## **2. Earlier Camera Models**

### **2.1 Contaflex Rapid**

Identical to Contaflex Super but does not include built-in exposure meter.

### **2.2 Contaflex IV**

The Contaflex IV is similar to the Super with the following differences:

1. The built-in exposure meter is not coupled to the lens.

2. Instead of a rapid-winding lever, a knob is used for film transport and shutter tensioning.

3. The film rewind knob has no crank.

4. There is no built-in accessory shoe; a separate one can be fitted to the camera.

### **2.3 Contaflex III**

The Contaflex III is identical to the IV except that it has no built-in meter.

### **2.4 Contaflex beta**

The physical appearance and operation of the beta is very much like that of the Conta-

flex IV. The lens and shutter system are very much like that of the Contaflex prima.

## **2.5 Contaflex alpha**

Similar to Contaflex beta, but no built-in exposure meter.

## **2.6 Contaflex II**

a) *Lens*: Zeiss Tessar  $f/2.8$ , 45mm standard lens, front element interchangeable.

b) *Shutter*: Synchro Compur, shutter speeds "B", 1 to 1/500 second, XM-synchronized. Built-in delayed-action device running for 8 seconds. Spring-loaded pre-selector diaphragm.

c) *Exposure meter*: Built-in, but not coupled to shutter.

d) *Other features*: Same as Contaflex IV.

## **2.7 Contaflex I**

Similar to Contaflex II without built-in exposure meter and without delayed-action release.

# **3. Lens Systems**

## **3.1 Converter lenses**

a) *Pro-Tessar System*: Used with Contaflex Super, Rapid, IV and III. Front element of Tessar removed and exchanged for 85mm long-focus Pro-Tessar  $f/4$  or 35mm Pro-Tessar  $f/4$ .

b) *Pantar system*: Used with Contaflex prima, beta and alpha. Front component of Pantar lens removed and replaced by either

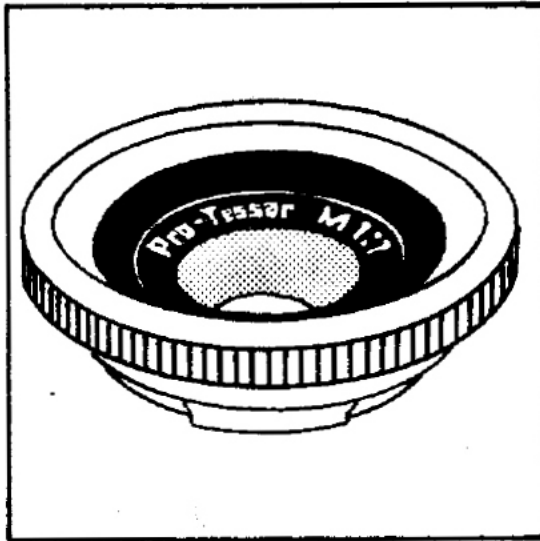

1-3.1a. Pro-Tessar lens is used on camera to make 1:1 reproductions.

30mm Pantar  $f/4$  wide-angle component or 75mm Pantar  $f/4$  telephoto component.

### 3.2 Stereo attachment

a) *Operation*: Stereo attachment produces two half-images, 16 x 23mm, side-by-side within normal image field of camera. The twin pictures are bound like normal slides, without having to cut them apart.

b) *Steritar-A*: For Contaflex I and II; held in front of camera lens with special attachment.

c) *Steritar-B*: For use with all Contaflexes which have 50mm (standard) Tessar lenses. Attached in place of front lens component.

d) *Steritar-D*: For use with all cameras which have 45mm Pantar lenses as standard; attached instead of front lens component.

e) *Close-up Steritar-B*: Similar to Steritar-B, but designed for close working distance of 8 ft. to 27 in.

1-3.2b. Stereo attachment makes two half-images on regular 35mm film frame.

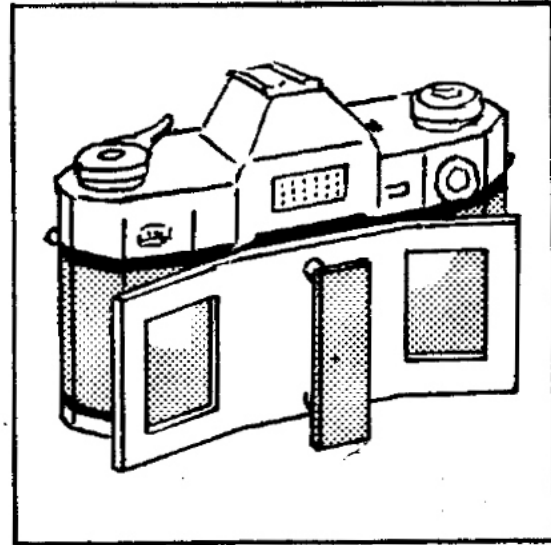

### 3.3 Monocular attachment

Zeiss monocular attachment 8 x 30B is a complete prism monocular and can be used independently as a telescope. When attached to any Contaflex with 50mm lens, it converts the optical system into a tele lens  $f/14$ , 400mm. The front lens component remains in place.

### 3.4 Close-up attachments

a) *Proxar lenses*: 50mm Tessar lenses focus down to 27 inches, 45mm Tessar lenses focus down to 36 inches, and 45mm Pantar

1-3.3. Zeiss 8 x 30B monocular converts 50mm lens into 400mm  $f/14$  lens.

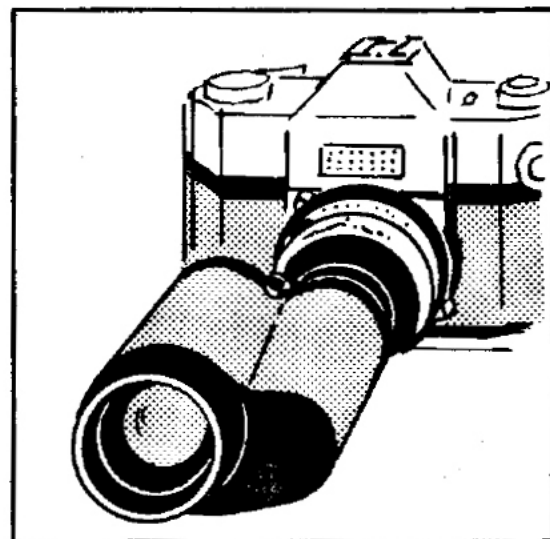

lenses focus down to 40 inches. For shorter distances, supplementary lenses (Proxar) can be slipped onto lens and focused normally without affecting any exposure adjustments. Five Proxar lenses are available: 100cm for distances down to 21 inches, 50cm for distances down to 13½ inches, 30cm for subjects down to 10¼ inches, 20cm for subjects down to 6¾ inches, and 10cm for subjects down to 3½ inches. Lens apertures should be stopped down to at least f/5.6; f/8 and f/11 are preferable.

b) *Pro-Tessar M 1:1 lens*: A three-component front element, which, when inserted into the camera, will make a six-element lens focus to a 1:1 image scale. For making black-and-white negatives from color transparencies but can be used whenever natural 1:1 size is desired.

c) *Copying stand*: An upright arm which clamps to a table top. Has a sliding bracket to which camera is attached. Used mainly for copying documents and photographing small objects.

## **4. Miscellaneous Accessories**

### **4.1 Lenshoods**

Available for all Contaflex lenses, they prevent flare and fog in pictures taken against the light. In bad weather they also protect the lens against rain and snow. They can be mounted with filters or Proxar lenses in place.

## **4.2 Eyesight correction lenses**

Correction lenses can be mounted to eyepiece to compensate for defects of vision so that focusing and composition can be performed without the aid of glasses. An optician's prescription is needed.

## **4.3 Filters (See Chapter III)**

## **4.4 Flash unit (See Chapter II)**

## **4.5 Microscope attachment**

Special attachments and tubes available to connect Contaflex to eyepiece of microscope to make photomicrographs.

## **4.6 Right angle finder**

Attachment to viewfinder eyepiece which enables camera to be held at chest level or lower with eye looking downward instead of straight ahead as at eye-level focusing position. Particularly useful when camera is mounted on copying stand or when low angles are desired. Also used to take pictures in one direction while viewing in another, without being observed.

## Chapter II

# OPERATING THE CAMERA

**NOTE:** The procedures which follow are for the Contaflex Super. Procedures for the Contaflex prima are identical except for some slight differences in section 2.2, Automatic exposure control. While handling of all Contaflex cameras is basically the same, there are differences from model to model, and these are explained at the end of this chapter.

## 1. Loading and Unloading

### 1.1 Opening the camera

Hold camera in left hand with back facing upwards. Locking keys at base of camera should be folded outwards with right hand and turned away from center of camera. Back can now be removed.

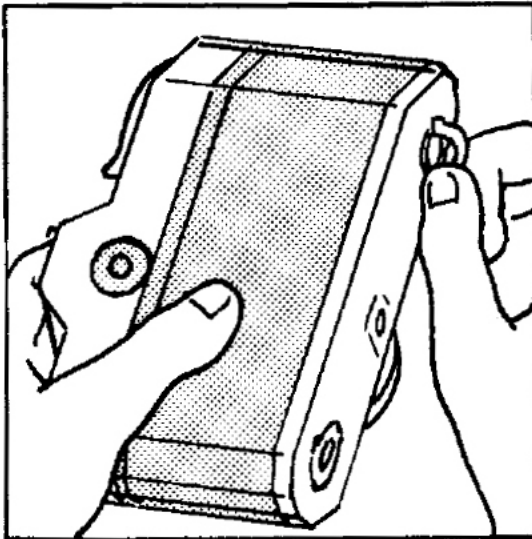

II-1.1 First step in opening camera is to lift locking key and turn it clockwise.

## 1.2 Loading film

a) *Attaching film to spool*: Attach film end to take-up spool by hooking one perforation hole over the small lug. This can be done with spool in camera or in hand. Film cartridge and take-up spool should then be inserted into the two film chambers so that the two prongs engage the cores of the spools. Rotate take-up spool with the right hand until the perforations of the film *on both sides* engage the teeth of the transport sprocket.

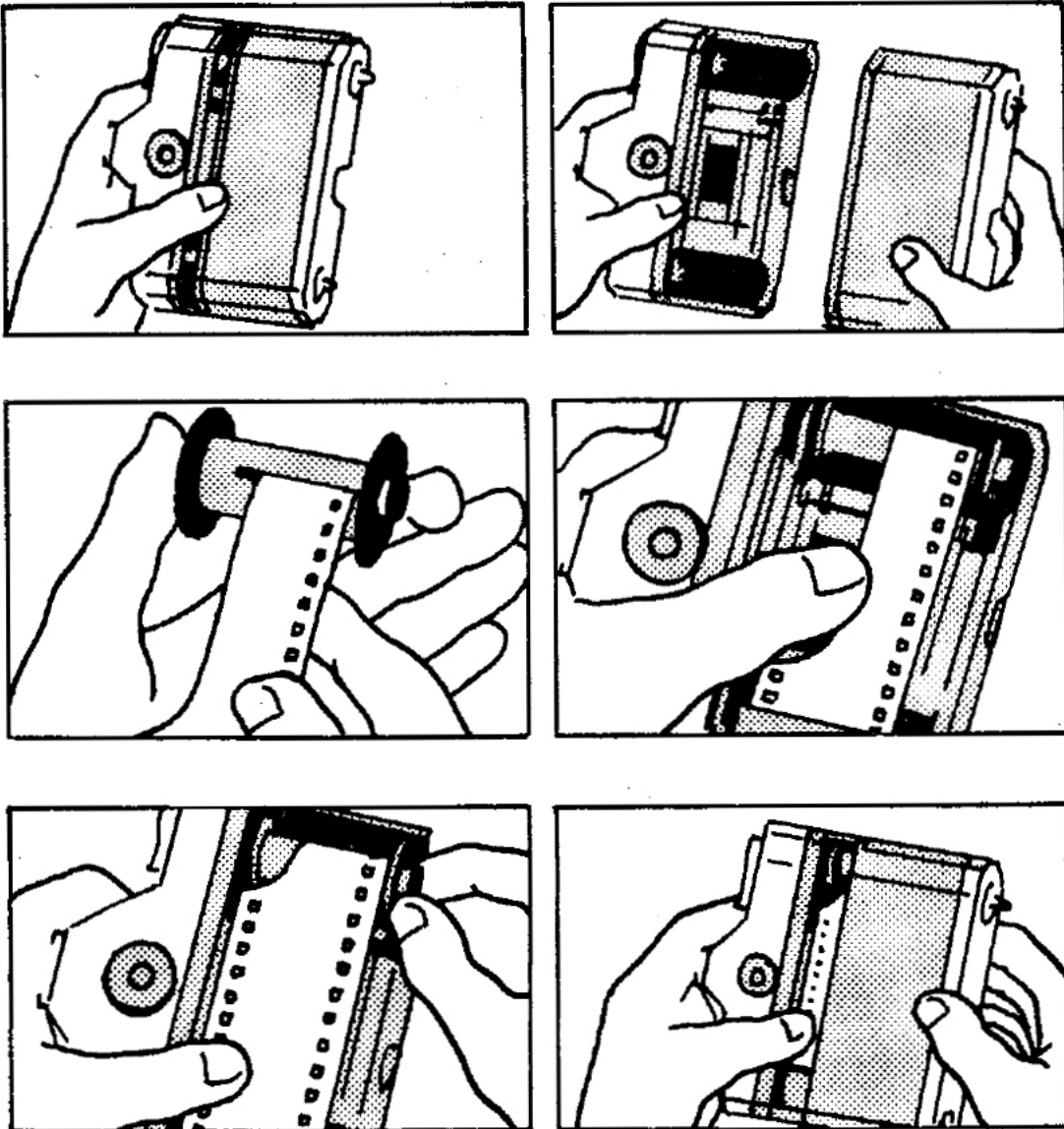

11-1.2a. Follow this procedure when loading a roll of new film into your camera.

b) *Close the camera:* With left thumb, hold film in contact with sprocket while sliding camera back into grooves of camera. Twin locking keys on base toward each other and fold them up. If keys cannot fold, back is not properly positioned.

### 1.3 Preparing first exposure

a) *Frame counter:* The frame counter, which is part of the film-advance mechanism, shows the number of unexposed frames remaining in the camera. With a 20-exposure cartridge in your camera, set the white indicator mark opposite the red triangle between 20 and 25. With a 36-exposure cartridge, set the white indicator to the red diamond between 1 and 36. Now, swing rapid-wind lever around with right thumb until it butts against stop. Press the shutter down to release it.

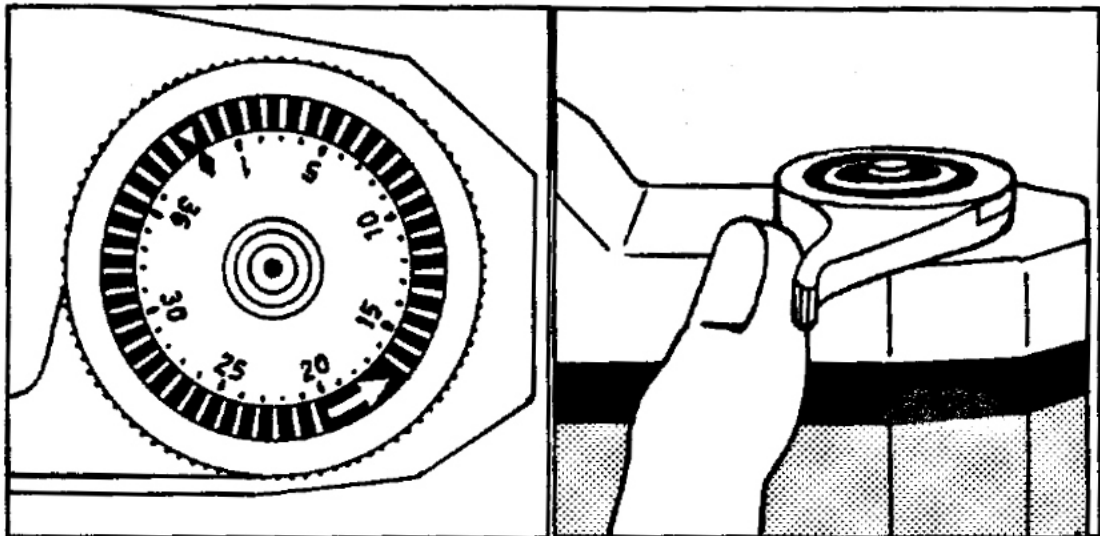

11-1.3a. After loading a 36-exposure roll of film into the camera, set film counter so that red diamond faces white triangle. Then make two blank exposures.

Repeat this sequence once more. The white mark will then appear opposite either the 20 or the 36 and thereafter will indicate the number of frames available.

b) *Film-wind checkup*: As film is advanced, rewind knob should rotate in opposite direction to engraved arrow. If it does not, unfold small crank in rewind knob and turn slowly in direction of arrow until a distinct resistance is felt. This will rewind any slack in the film if it is properly attached to the take-up spool. If no resistance is felt after a few turns, open camera back to make sure film is properly secured to take-up spool.

c) *Entering film speed, Contaflex Super*: Speed of film in use (see Chapter III) should then be transferred to the automatic exposure control of the camera. Press the film speed scale in the light selector disc inwards and turn it until the desired ASA number coincides with the black triangle. When using filters, the film speed may be set opposite the filter factor indicator, 2X or 4X.

11-1.3c. Press speed scale in light selector disc inwards and turn it until required ASA figure coincides with black triangle.

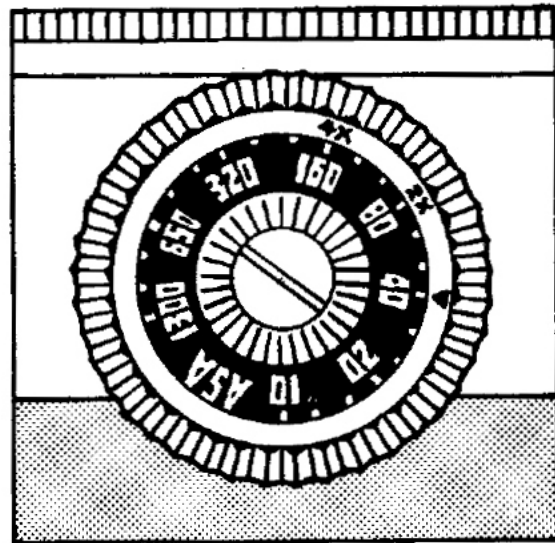

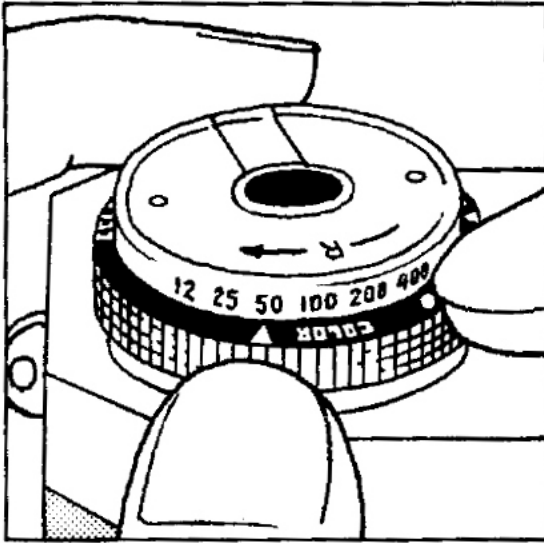

11-1.3c. Type of film and its ASA rating should be entered on film type indicator.

d) *Entering film speed, Contaflex prima:* Film speed scale is underneath lens. Press in small lever and turn ring to left or right in order to bring desired ASA number opposite triangular indicator mark. If filters are used, bring film speed opposite filter factor 2X or 4X, as appropriate.

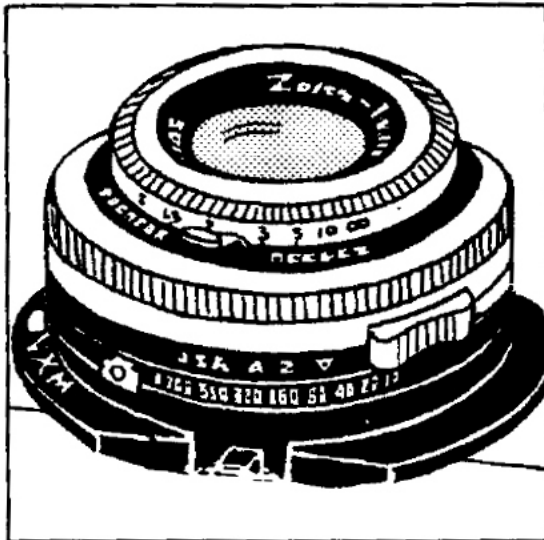

11-1.3d. ASA ratings for films are dialed into Contaflex prima on scale at base of lens mount.

e) *Film type indicator:* Turn film type dial on rewind knob until indicator mark for type of film being used appears opposite ASA reminder scale.

## 1.4 Unloading

If camera is loaded with a commercial cartridge, the film must be rewound into the cartridge before unloading. The locking key on the back marked "R" is folded up and turned so that it points to the letter "R". Fold out the countersunk crank from the rewind knob and turn it in the direction of the arrow until a slight pull is felt, which will signal that the film has been rewound into the cartridge. Then, remove the back and take out the cartridge. Remove any dust or film particles left inside the camera.

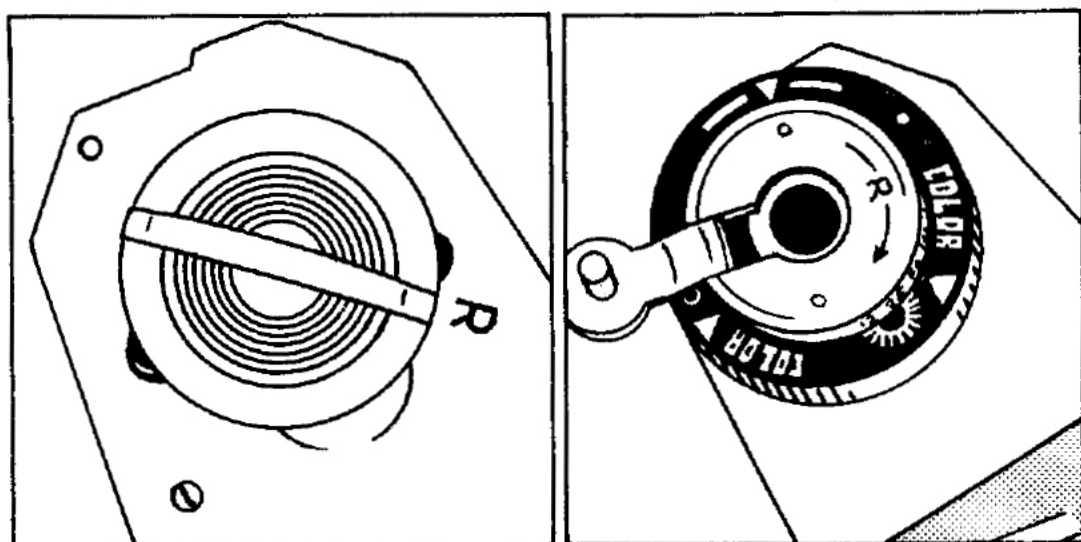

11-1.4. To unload camera, lift locking key and turn it to face R. Then fold out countersunk crank and wind it in direction of arrow.

## 1.5 Cassettes

a) *Use:* The cassette is a lightproof film container which can be used in place of the take-up spool or which can be loaded with film and used in place of a commercial cartridge. If desired, two cassettes can be used; one as the film supply and the other as the take-up. When a cassette is used as a take-up, it is not necessary to rewind the film after the last

exposure. Instead, the camera back is opened and the film is detached from the supply cassette. The use of a take-up cassette makes it possible, also, to change from one film to another even though the first film is not fully exposed. The only film loss is the short length between the take-up and supply. Critical workers find that they minimize scratching by not having to rewind film. Some photographers prefer to load their film for greater variety as well as for economy.

b) *Changing film*: When changing an incompletely exposed film, protect the last exposure by further exposing two blanks. Then the camera can be opened safely. When this film is restored, remember that the two blanks must be advanced into the take-up before new exposures are made.

c) *Rewinding into cassettes*: If film is to be rewound into a cassette, the end of the film must be secured to the center slot of the spool before the film is loaded into it.

## **2. Measuring the Light**

### **2.1 Shutter speed ring**

Figures to the right of "B" denote fractions of a second ( $60 = 1/60$  second, etc.). "B" stands for "brief time." It also stands for 2 seconds as a required exposure time. All green figures, as well as "B", are time exposures. None of them operates automatically through the shutter mechanism. They merely indicate the length of time the shutter release is to be held depressed.

11-2.1. Top of lens mount shows shutter speed ring, f/stop scale, depth of field scale, and footage indicator.

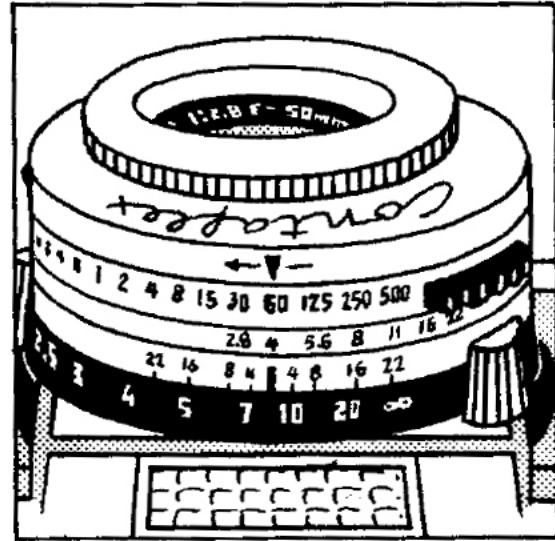

## 2.2 Automatic exposure control

a) *Contaflex Super*: Turn shutter speed ring to desired setting. If aperture scale reaches its final value, continue turning shutter speed ring if necessary. Now, observe position of pointer in window on top of camera or on side of viewfinder screen. Turn light selector disc one way or the other until the pointer is in the center of the circular mark on top of the camera or opposite the centered setting mark in the viewfinder. This operation automatically sets the lens aperture. You now can make any selection of mutually related shutter speeds and lens apertures merely by turning the shutter speed ring. When you turn to a higher shutter speed, you will automatically open the lens aperture wider (smaller f/number), while if you turn to a slower shutter speed, you will automatically narrow the lens aperture (larger f/number).

b) *Contaflex prima*: While holding camera horizontally (even though you later turn it vertically), aim camera at subject and turn

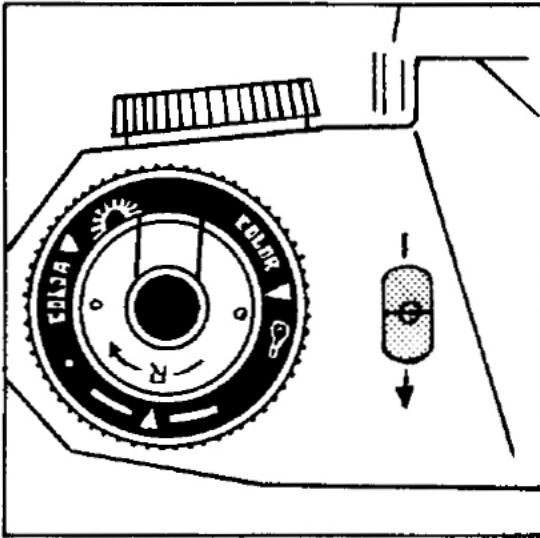

11-2.2a. Automatic exposure control is maintained by aligning needle in window on top of camera.

exposure setting disc so that the two pointers of the exposure meter coincide. Now turn shutter speed ring to find most suitable shutter speed/aperture pairing.

### 2.3 Manual settings

a) *Contaflex Super*: Select desired shutter speed first. Then, turn light selector disc until desired lens aperture appears opposite indicator mark and shutter speed.

b) *Contaflex prima*: Select desired shutter speed first. Then, disengage coupling of lens aperture ring and turn to desired lens aperture.

### 2.4 Snapshot setting

a) *Contaflex Super*: To be ready for the greatest variety of pictures without having to focus for each one, pre-set the camera for that shutter speed-f/number combination which includes f/8. F/8 is marked in red. Distance should be set at 20 ft., also marked in red. Everything between 10 ft. and infinity will be recorded sharply.

11-2.4a. Set footage indicator to 20, f/stop scale to 8 for depth of field from 10 ft. to infinity.

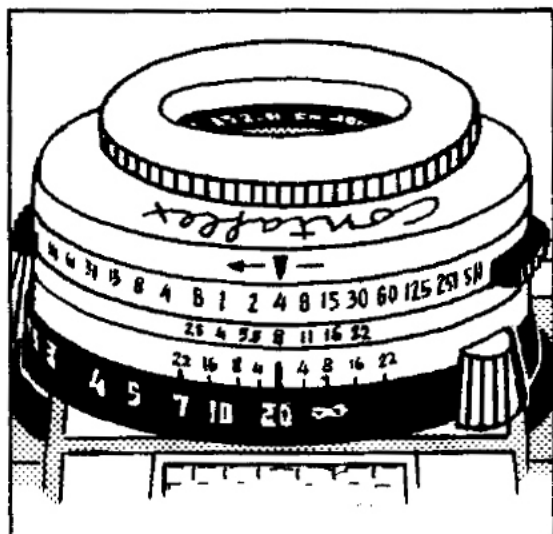

b) *Contaflex prima*: Same as Super but settings are  $f/8$  and 15 ft. Everything between 8 ft. and infinity will be recorded sharply.

### 3. Picture-taking

#### 3.1 Holding the camera

a) *Horizontal pictures*: Hold camera cradled in both hands with right index finger resting over shutter release. Hold camera snugly against cheekbone, using it as part of support for camera. Legs should be slightly apart, one foot forward for greater stability in order to reduce likelihood of movement during exposure.

b) *Vertical position*: Hold camera snugly against forehead for added support. Stand as above.

#### 3.2 Shutter release

Press shutter release down firmly but gently. Do so with a squeezing rather than a tapping motion. Abrupt pressure on shutter release might cause movement and blurring of

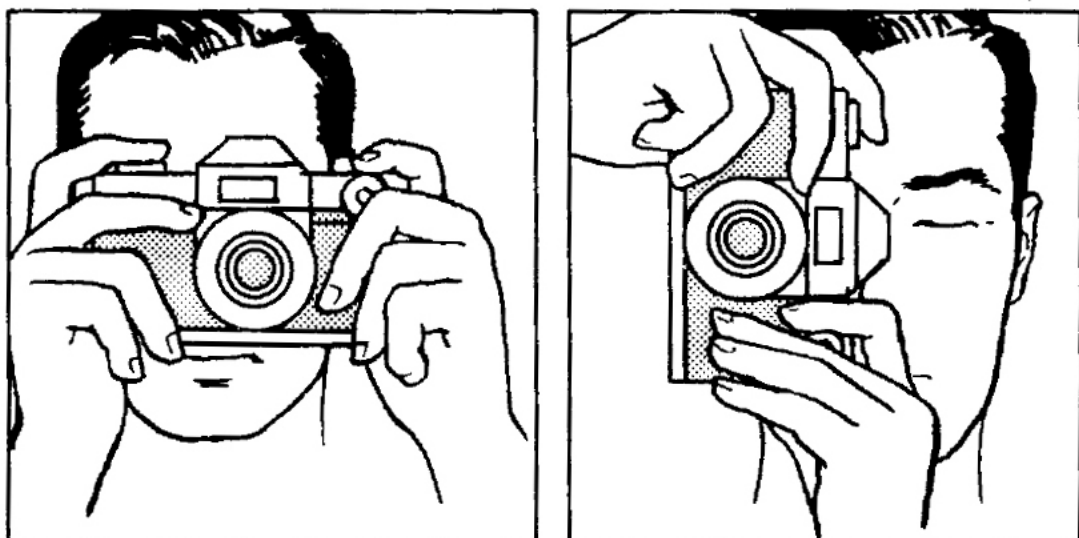

II-3.1. Proper positioning of camera and hands for horizontal and vertical picture-taking.

image. Shutter releases as slow as  $1/30$  second can be hand-held although  $1/60$  should be ordinary limit. Shutter speeds slower than  $1/30$  should be on solid support or tripod should be used. If hand-held, lean against wall, tree, back of chair, etc.

### 3.3 Rangefinder focusing

In innermost circle of viewfinder you will observe two images separated from each other by a thin line. When you turn the distance ring, these move in opposite directions. The distance is correctly set when the two partial images are exactly aligned and form one single undistorted image. Look for a sharp perpendicular line within the subject such as a tree or the edge of a house or the side of the face on which the correct alignment should be checked. When taking pictures vertically, a horizontal line should be chosen.

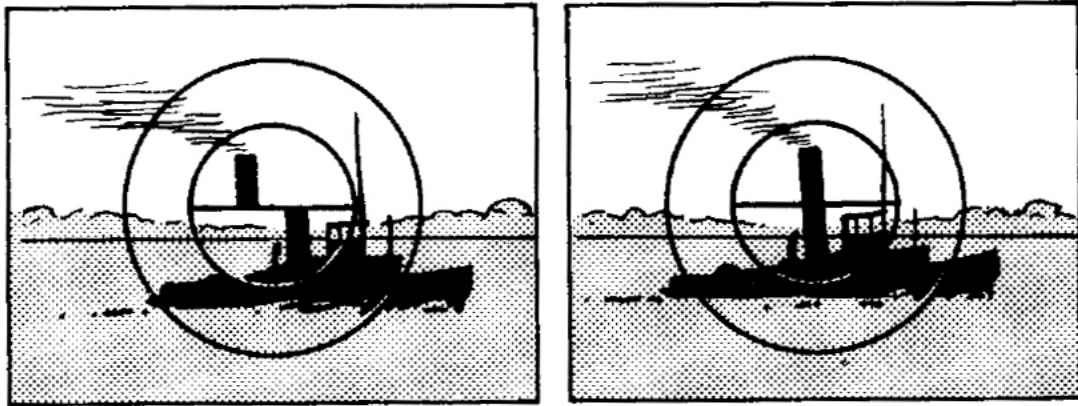

11-3.3. Split-image rangefinder shows out-of-focus image at left, in-focus image at right.

### 3.4 Ground-glass screen focusing

With objects which have no distinct vertical lines, focusing with the split-image rangefinder will not be satisfactory. You will also have difficulty if the subject moves too rapidly. Then the fine-screen ring should be used for focusing in the same way a normal ground-glass screen is used. Do not focus with the area outside the circular fine-screen ring.

### 3.5 Depth-of-field scale

a) *Zone of sharpness*: Sharpness of the picture is not limited to objects at the exactly focused distance. The sharpness will also cover a certain range nearer and farther from this point. At the full aperture of  $f/2.8$ , this zone of sharpness is comparatively small but as the lens is stopped down to smaller apertures, the zone of sharpness grows deeper. This zone of sharpness is called the depth of field.

b) *Depth-of-field scale*: Between the lens aperture ring and the distance scale, you will notice two sets of  $f$ /numbers on either side of the indicator mark. These numbers give

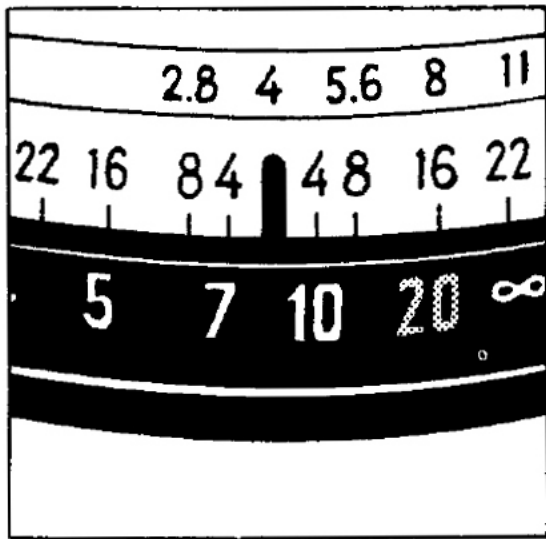

11-3.5b. Close-up of depth-of-field scale showing 20 ft. setting marked in red.

you an approximate zone of sharpness at any given lens aperture. You can set the camera in the ordinary way and then look for the lens aperture number on both sides of the indicator mark. Opposite the twin aperture numbers, you can read off the two distance scale numbers (or approximate distances between the numbers) and you will have the near and far points of sharp focus. If you prefer, you can predetermine the depth of field desired and select the lens aperture needed to obtain that depth of field.

### 3.6 Delayed-action release

At the base of the lens, you will find a VXM setting lever. At the "V" setting the delayed-action release (or self-timer) is brought into action. When the release knob is depressed, a retarding mechanism is set in motion which opens the shutter at about 8 seconds afterwards. Time exposures cannot be made with the self-timer. If flash lamps are connected to the shutter, set to "V" and the delayed-action mechanism will fire the flash

11-3.6. VXM setting lever at base of lens is set at X, indicating use of electronic flash.

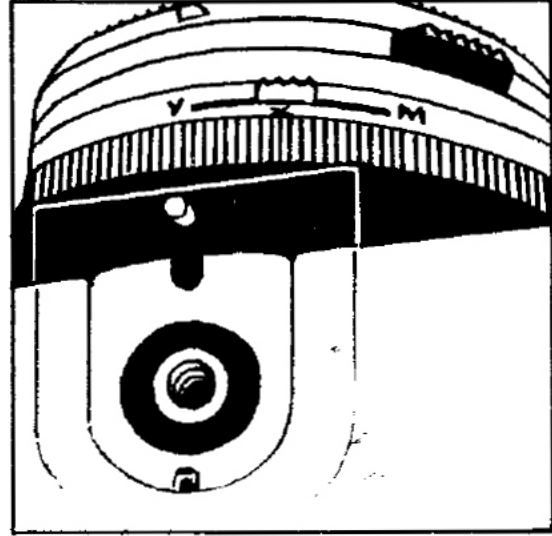

as though it were set at the "X" setting. The synchro-lever can be set to "V" only when the shutter has been tensioned and the lever depressed.

11-3.7b. Proper method for inserting interchangeable lens elements.

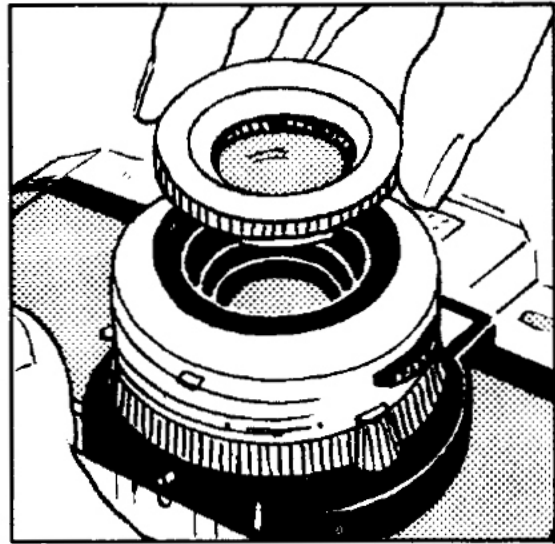

### 3.7 Interchanging lens components

a) *Removing front element:* Hold Contaflex in left hand and press the lock pawl in direction of lens with thumb. The milled front ring of standard lens is then turned with right hand to the left until it comes to a stop; a slight resistance has to be overcome. Lift the front element upwards from its bayonet mount.

b) *Insertion*: Red dot of front lens unit must be opposite red dot of lock pawl. Lens unit is pressed home with a right turn until an audible click is heard.

## 4. Flash Pictures

### 4.1 Flash equipment

a) *Ikoblitz 4*: The Ikoblitz 4 B-C flash unit is made of almost unbreakable plastic material. It slips directly into the accessory shoe and after being attached to the flash contact is ready for use.

b) *Other flash units*: Any other flash unit for flash bulbs or electronic flash can also be used with the Contaflex for attachment to the base of the camera with an adapter bracket or for direct attachment to the accessory shoe. The flash unit must have a continental P-C connector tip or an adapter.

### 4.2 Synchronization

a) *X or V settings only*: M2, M2V, M25, M25B, AG-1 and AG-1B bulbs should be set at 1/30 second or slower. SF or SM bulbs should be set at 1/125 or slower. Electronic flash can be set at any shutter speed.

b) *M settings*: 5, M5, M5B, 25, 25B can be used at any speed between 1/60 and 1/500.

c) *Optional "V" settings*: When bulbs which ordinarily are used at "M" setting are used at "V" setting, shutter should be set at 1/30.

## Table of Exposure Times for Flashbulbs

Flashbulb	Synchro-Lever set to	
	X or V	M
Osram		
XM 1, XM 5, SO, SO blue	1— $\frac{1}{30}$	$\frac{1}{60}$ — $\frac{1}{500}$
XM 1 B, XM 5 B	1— $\frac{1}{30}$	$\frac{1}{60}$ — $\frac{1}{125}$
Philips		
PF 1, PF 5, PF 60	1— $\frac{1}{30}$	$\frac{1}{60}$ — $\frac{1}{500}$
F 1/blue, PF 5/blue		
PF 60/blue	1— $\frac{1}{30}$	$\frac{1}{60}$ — $\frac{1}{125}$
PF 100, PF 100/blue	1— $\frac{1}{15}$	$\frac{1}{30}$ — $\frac{1}{60}$
General Electric and Westinghouse		
5, 8, 11, 22, M 5	1— $\frac{1}{30}$	$\frac{1}{60}$ — $\frac{1}{500}$
M 5 B	1— $\frac{1}{30}$	$\frac{1}{60}$ — $\frac{1}{125}$
M 2, M 2 B, M 25 B	1— $\frac{1}{60}$	—
SM	1— $\frac{1}{125}$	—
50	1— $\frac{1}{15}$	$\frac{1}{30}$
Sylvania		
No 0, No 2, Bantam 8, Press 25, 40, M 5	1— $\frac{1}{30}$	$\frac{1}{60}$ — $\frac{1}{500}$
M 5 B	1— $\frac{1}{30}$	$\frac{1}{60}$ — $\frac{1}{125}$
M 2, M 2 B, M 25, M 25 B,	1— $\frac{1}{60}$	—
SF	1— $\frac{1}{125}$	—
3	1— $\frac{1}{15}$	$\frac{1}{30}$
Electronic flash	1— $\frac{1}{500}$	—

## **5. Contaflex Rapid**

### **5.1 Similarities to Contaflex Super**

All physical details of the Contaflex Rapid are the same as those of the Contaflex Super except for the omission of the exposure meter and the addition of an exposure value scale. Accordingly, those steps in the preceding material which relate to automatic exposure control should be ignored. All other operations, except as next indicated, are identical.

### **5.2 Exposure value system**

By pressing the exposure value setting knob located adjacent to the shutter speed ring, towards the body of the camera, the adjacent red dot should be moved until it coincides with the required value on the red exposure value scale. Intermediate or half-values can also be set. As the ring with the red dot can only be moved to a limited degree, it will sometimes be necessary to move the aperture and shutter speed setting ring as well. The exposure value is determined from the exposure table packed with the film or through the use of an exposure meter which gives exposure value readings. Once the exposure value is set on the lens mount, all aperture and shutter speed settings are coupled so that they can be paired for desired combinations of lens apertures and shutter speeds. If manually adjusted settings are desired, independent of the exposure value system, the shutter speeds should be set first. Then, the lens aperture can be set by uncoupling the aperture ring.

## **6. Contaflex IV and III**

These two models preceded the corresponding later models Super and Rapid. The built-in exposure meter of the Contaflex IV is not coupled. The Contaflex III has no meter at all. In general, operation of both these models is similar to that of the Contaflex Rapid, described above. Film advance, however, is through use of a knurled knob rather than a rapid-wind lever. The rewind knob does not have a self-contained crank.

## **7. Contaflex beta and alpha**

The built-in exposure meter of the beta is not coupled to the lens. The alpha has no built-in meter. The lens, shutter, focusing and depth-of-field scales are similar to the Contaflex prima. Film advancing and rewinding are similar to the Contaflex IV and III.

## **8. Contaflex II and I**

Basic procedures of loading and unloading film, focusing, flash synchronization and delayed-action release are the same as for all subsequent models. Film advance and rewind procedures are similar to those of the Contaflex IV and III. One minor difference in focusing is that the front lens cell is turned rather than the entire lens mount. The lens aperture and shutter speed rings are not cross-coupled. They are set independently. No exposure value scale is incorporated. The front lens cells are not removable. A tele attachment was available called the Teleskop converting the standard lens to a 3-inch lens. The Contaflex II had a built-in uncoupled exposure meter.

## FILMS AND FILTERS

### 1. Black-and-white Film

#### 1.1 Film characteristics

a) *Film speed*: Faster films more sensitive to light; require less exposure under identical conditions than slower films. Slower films usually have finest grain and sharpest image contours. Faster films usually are grainier, lose contrast.

b) *Graininess*: Smoothness or coarseness of tonal areas of film when enlarged or projected. Fine-grain film smoother texture than coarse-grain film. Fineness of grain helps preserve image details.

c) *Contour sharpness (acutance)*: Refers to sharpness of tonal separation between dark and light objects. Sharpest is knife-edge separation. In poorest, tonal areas soften into each other. Good contour sharpness heightens effect of image sharpness apart from fineness of grain.

d) *Film contrast*: Contrast refers to range of difference between least dense and most dense (or dark) areas. Contrasty film jumps from light to dark in very few steps. Film of low contrast has shorter tonal scale with softer gradation. Films are popularly characterized by their speed, grain structure, acutance, contour sharpness, and gradation

(tonal range). Usually, the faster the film, the more grain, and the less acutance and tonal range.

## 1.2 Slow films

For biggest enlargements, sharpest image contours, finest grain. Ample sensitivity for vast majority of pictures in daylight. Tendency toward being contrasty; poor with contrasty subjects but good for subjects of little contrast.

Name of Film	ASA Exposure Index
Adox KB-14	40
Agfa Isopan-FF	25
Ilford Pan-F	
Kodak Panatomic-X	40
Perutz Pergrano-14	50

## 1.3 Medium films

Best all-around films. Excellent grain. Very good contour sharpness. Best tonal scales. For practically all daylight subjects, flash and some indoor lighting.

Name of Film	ASA Exposure Index
Adox KB-17	80
Agfa Isopan-F	100
Gevaert Gevapan-27	64
Perutz Peromnia-21	100

## 1.4 High-speed films

For wide variety of conditions, leaning toward adverse lighting. Best "available light"

films; reasonably fine grain, good image contrast.

Name of Film	ASA Exposure Index
Adox KB-21	125
Agfa Isopan-SS	200
Gevaert Gevapan-30	125
Gevaert Gevapan-33	250
Ilford FP-3	125
Kodak Plus-X Pan	160
Perutz Peromnia-25	250

### 1.5 Ultra-high speed films

Unusually sensitive, for adverse lighting, such as dusk outdoors, indoor lighting without flash, street illumination. Grainy, relatively low contrast.

Name of Film	ASA Exposure Index
Agfa Isopan Ultra	400
Agfa Isopan Record	1250
AnSCO Super Hypan	500
Gevaert Gevapan-36	500
Ilford HP-3	400
Ilford HPS	800
Kodak Tri-X Pan	400

### 1.6 Special films

a) *Copying films*: For copying line materials. Very contrasty. Not recommended for other purposes. Generally available is Kodak High Contrast Copy Film.

b) *Direct positive films*: For positive projection transparencies when developed according to manufacturer's instructions. Kodak Direct Positive Panchromatic ASA exposure index 64.

c) *Infrared films*: Used when important to cut through haze, when nighttime effects desired during daylight exposure and for special medical and scientific purposes. Infrared filter required. NOTE: After finding distance through rangefinder or physical measurement, use "R" on lens mount as pointer to desired distance.

## 2. Black-and-white Filters

### 2.1 Purposes of B-W filters

Colored filters hold back complementary colors. Thus, green filter holds back red light thereby making red objects darker and green objects lighter in final print. Conversely, red filter holds back green and renders red objects lighter, green objects darker. Certain filters exclude excessive ultraviolet radiation which otherwise creates haziness.

### FILTER TABLE (Black-and-white films)

Filter	Uses	Filter factor Day
Yellow	Darken blue sky, bring out clouds, other light objects against blue sky. Snow: reduce excessive blue sky reflection. Reduce haziness of distant scenes.	1.5-2

Yellow-Green	Preferred for outdoor portraiture when darkened sky desired; doesn't lighten lips. Lightens green foliage. Other uses similar to yellow filter.	2-3
Orange	Similar to yellow, but more pronounced effects. Darkens green foliage; lightens autumn foliage. Subdues freckles. Simulates night effects, daytime, with slight underexposure and overprinting.	3-5
Blue	Copying, to darken faded or yellowed handwriting. Washes out blue sky completely.	1.5
Ultra-violet	Reduces haziness caused by excessive scattering of ultra-violet light. Landscapes, seascapes, high altitudes.	0-1.2
Red	Extreme contrasts; similar but more pronounced in effect to orange filter. "Washes out" lips and skin tones in pictures of people.	

	Variable factor; bracketed exposures recommended.	6-25
Polarizing	Reduces or eliminates reflections from water, glass or other polished surfaces. Also used in color photography.	2.5-3
Infrared (with IR film)	Haze penetration, most effective. Document photography. Medical photography. Simulated night effects made during daytime.	6-100

### 3. Color Films

#### 3.1 Color film characteristics

a) *Reversal films*: Developed as transparencies for direct or projected viewing. Balanced for specific types of lighting, including daylight, tungsten (artificial light) and clear flash. These different types of lighting should not be mixed in same scene. NOTE: Blue flash bulb and electronic flash considered same as daylight. If film intended for one type of light is to be used with another, conversion filter must be used over lens. (See III-4.2.)

b) *Negative color films*: Can be used with different types of light. (Balancing filters used when enlargements are made.) Although you can mix lighting sources on same film, *you cannot mix lighting sources in any one*

exposure. Whenever possible, advisable to adhere to one lighting source throughout to minimize error when processing color prints.

### 3.2 Daylight reversal films

a) *Medium speed*: Finest grain with medium speed films, particularly Kodachrome II.

Name of Film	Daylight Exposure Index	Tungsten Exposure Index (with conversion filter)
Agfa	50	....
Ansochrome	32	8
Ektachrome	32	10
Kodachrome	10	6
Kodachrome II	25	12
Perutz 50 Color	50	....

b) *High speed films*: For action as well as for uncertain daylight conditions.

Super		
Ansochrome	100	25
High Speed		
Ektachrome	160	—

### 3.3 Tungsten reversal films

For use with artificial light, tungsten-type, as indicated:

Name of Film	Daylight Exposure Index (with conversion filter)	Tungsten Exposure Index
Super		
Ansochrome	80 <sup>1</sup>	100
Kodachrome		
Type A	10 <sup>2</sup>	16

## High Speed

### Ektachrome

Type B                      64<sup>1</sup>                      125<sup>3</sup>

<sup>1</sup> With Wratten filter 85B

<sup>2</sup> With Wratten filter 85

<sup>3</sup> Requires 3200° K lighting.

### 3.4 Flash reversal films

Intended for use with clear-type flash bulbs. See film instructions for conversions.

Ansochrome Flash Type

Kodachrome Type F

Ektachrome Type F

### 3.5 Negative color films

Name of Film	Daylight Exposure Index	Tungsten Exposure Index
Agfa Negative CN-14	20	16
Agfa Negative CN-17	40	32
Kodacolor	32	24

## 4. Color Film Filters

### 4.1 Conversion filters

a) *85C (Type F)*: Use with Type F Kodachrome, Ektachrome or Ansochrome when shooting outdoors in daylight.

b) *85 (Type A)*: Use with Kodachrome Type A when shooting outdoors in daylight.

c) *80A (PF, Photoflood)*: Use with Kodachrome, Ektachrome or Ansochrome Daylight to take pictures with photofloods.

