

Contax

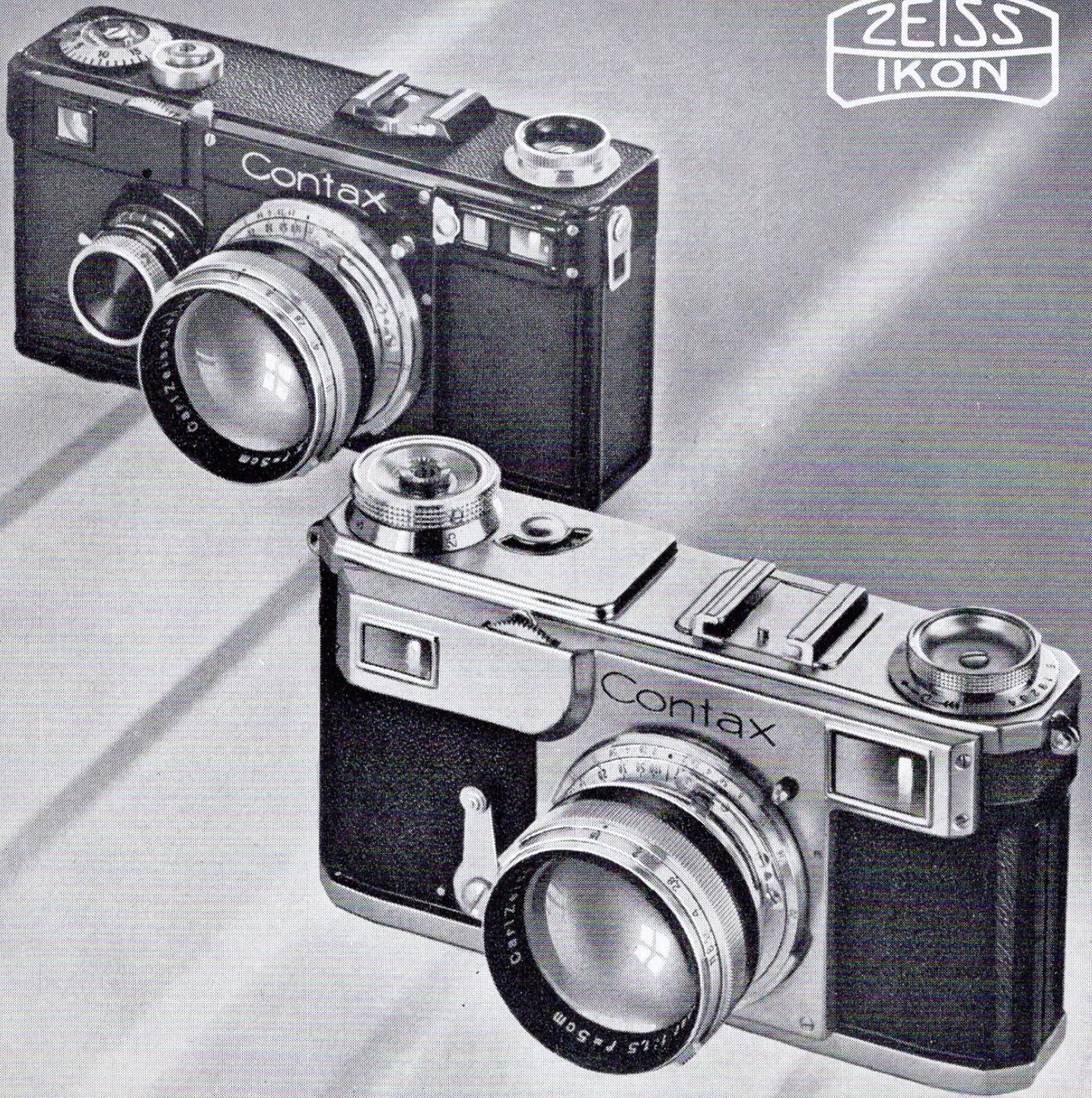

ZEISS LENSES

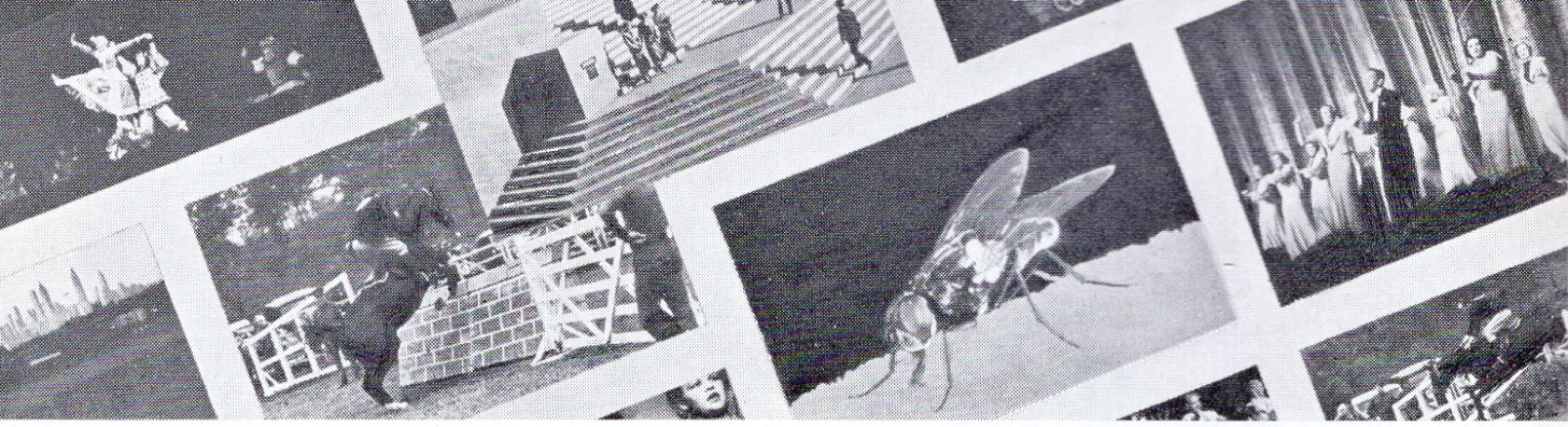

UNLIMITED SCOPE



CONTAX—*Universal Miniature Camera*

IN THE CONTAX, Zeiss Ikon has produced a camera so universal in scope that it really represents several cameras in one. This extreme versatility is the result of many constructional features, of the use of interchangeable Zeiss lenses, and of numerous accessories. The CONTAX takes critically sharp negatives under the most difficult lighting and speed conditions. Indoors or out, in daylight or in ordinary artificial light, "CONTAX gets the picture."

With its load of thirty-six exposures on one roll, you can snap one shot after another in quick succession. Ready at an instant's notice, you catch your subjects unposed—true-to-life candid shots full of character and human interest . . . children at play, friends in interesting attitudes, banquet scenes, stage pictures, etc. And at sporting events your CONTAX will snap the fastest action, getting all the detail and tone value that make a picture pulse with life. If you are a nature fan you will find your CONTAX invaluable in taking telephoto shots of birds and wild animals, or close-up studies of insects, flowers, etc. Or if your interest lies along scientific lines, your same CONTAX can readily be adapted to the making of copies from books, charts, prints, etc., or photomicro pictures of every description.

In short, the CONTAX offers unlimited scope in picture making. It opens the way to new and exciting adventures in photography.

To secure such extremely sharp negatives as the CONTAX makes—negatives capable of considerable enlargement—35 mm. motion picture film is used. The Zeiss lenses are especially designed to insure sharpest definition over the whole negative. Minutely accurate focusing—so necessary in the miniature camera—is assured by a mechanism of extra-

ordinary precision, yet easily operated. The film lies absolutely flat in the film gate to insure the same accuracy as with the plate and plate-holder, and the shutter is so designed that all single points of the negative receive even exposure.

CONTAX is a product of Zeiss Ikon, Dresden, Europe's largest and leading camera concern. In design, construction, and operation, the CONTAX is the foremost 35 mm. miniature camera.

CONTAX I (Black) CONTAX II (Chromium)

CONTAX is now available in two models, CONTAX I and the new CONTAX II. Basically, both models offer the same fundamental photographic possibilities and accommodate the same range of lenses and accessories. They differ, however, in the following respects.

The CONTAX I is finished in nickel and black enamel, whereas the CONTAX II is finished in chromium, partly dull and partly bright.

In the new CONTAX II (Chromium) the range-finder and view-finder are combined in one opening, giving speedier manipulation and a larger image. The winding knob is situated on top of the camera with the shutter release conveniently located in the center of the knob. The top speed has been increased from 1/1000th to 1/1250th of a second. The whole scale of shutter speeds is always visible. Adjustments can be made both before and after winding the shutter, same as with CONTAX I. A self-timing device permits delayed action release for taking your own picture; the release takes place automatically after a delay of approximately twelve seconds. The same mechanism also permits an automatic exposure of one second.

The CONTAX I (Black) which has so many friends, will be continued. The new CONTAX II (Chromium) is priced somewhat higher.

CONSTRUCTION OF CONTAX

Shape of Body

To avoid blurring due to movement of the camera during exposure, the camera must be firmly held by the photographer. Weight and dimension of the camera influence this. Research and actual experiment have proved that best results are obtained with a camera almost rectangular, with corners slightly rounded off. This is the shape of the CONTAX. The rectangular shape helps the operator to keep the camera level and to avoid a tilted position. The CONTAX has an all-metal body of light metal casting. Cast camera bodies are known for their rigidity.

Accessibility

All cameras, especially those using roll or motion picture film, must be kept thoroughly clean. Dust or small particles of film or perforation chips accumulate and may cause trouble. The surface around the picture aperture and the sliding track of the film require special attention. The interior of the CONTAX is easily and completely accessible. Simply remove the back, and the camera is open for easy and thorough cleaning. This removable back has many other advantages. First, it renders the insertion of daylight loading spools as easy as in any roll film camera, and further, it permits the use of a ground glass screen, plate back, and other accessories. This detachable back is made of a specially rigid metal.



Correct way to hold camera

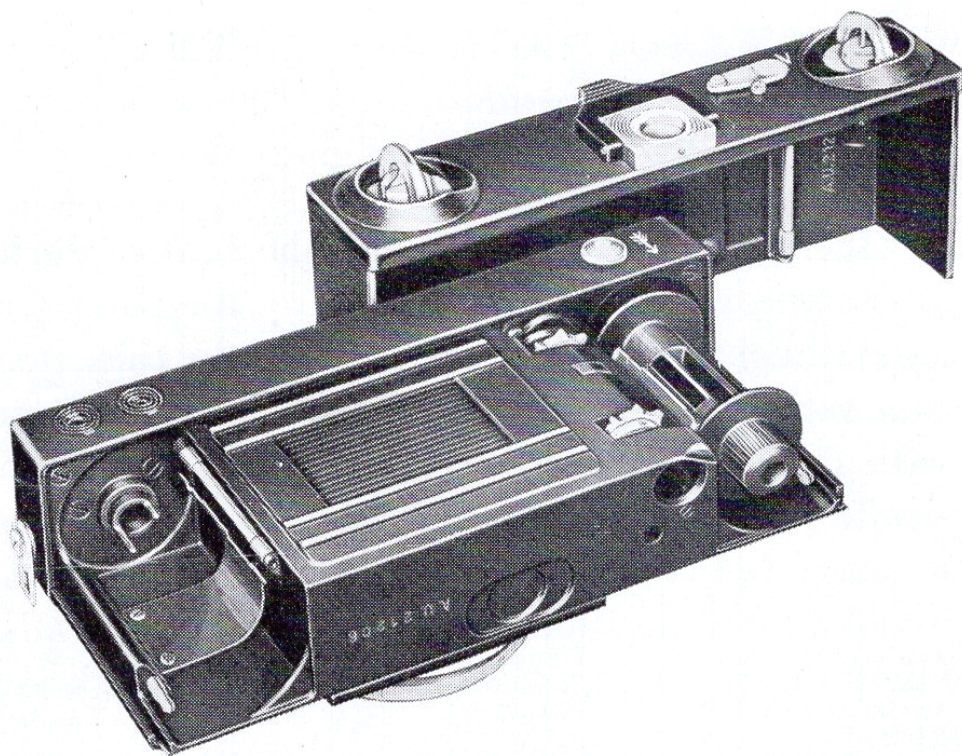

CONTAX opened, showing accessibility of interior

When fitted in place, the camera is absolutely light-tight, and the spring pressure plate ensures that the film will be kept flat in the picture aperture at all times.

Focusing

For negatives which are to be enlarged, as practically all miniature negatives are, there must be no guesswork. They must be absolutely clear and sharp. The only sure way of avoiding errors of focus is to couple the focusing mechanism of the lens with an accurate range-finder, as embodied in the CONTAX.

Operating the knurled wheel actuates the range-finder and at the same time automatically focuses the lens.

The CONTAX Range-finder

The accuracy of an optical range-finder depends to a great extent upon the length of its so-called optical base. The ideal

range-finder must cover the requirements of short- and long-distance photography.

The CONTAX is equipped with a range-finder of approximately the full length of the camera—about four inches. This gives it a high degree of accuracy for all lenses and for all distances.

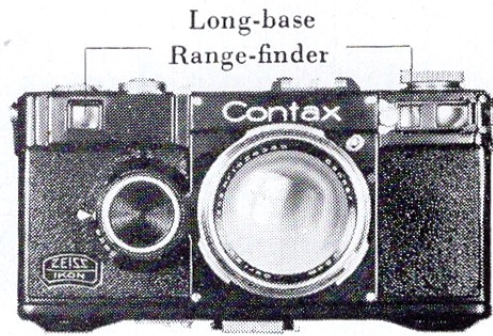

The range-finder of the CONTAX is built-in so that it forms an integral part of the camera body and is completely protected against damage. It is of the wedge-type construction which is not only inherently more accurate but also more durable and shock-proof.

The range-finder gives an extremely bright and clear image. The mechanism of an optical range-finder brings together two images of the same object. When they are exactly superimposed the correct focus has been obtained. It is not always easy to superimpose images of the same color. Tinted glass, which is frequently used for one image, reduces up to forty percent of the light, and thereby greatly decreases the efficiency of a range-finder. The CONTAX avoids this disadvantage by the ingenious arrangement of a semi-transparent gilded mirror and a prism producing two images, one red and one green (complementary colors). These, when brought together in focus, produce one clear and brilliant object in approximately natural colors. The automatic coupling of the range-finder to the focusing mount of the lens insures an extremely high degree of accuracy in focusing.

The Automatic Focusing Device of the CONTAX

In designing the focusing mechanism of the CONTAX, two very important points had to be taken into consideration. First, the highest possible accuracy of mechanical parts;

second, to make them immune to external influences which might destroy the exact relation between lens and measuring device. The mechanism was, therefore, designed to insure utmost accuracy. It was made solid, substantial, and rigid, so that it would withstand wear and tear, and it was housed within the camera so that all mechanical parts would be fully protected.

The user superimposes the images by observing the action of the range-finder, as he rotates the knurled wheel, which at the same time automatically focuses the lens. Once the two images are perfectly superimposed, their vertical lines forming one line, the lens is in exact and critical focus.

CONTAX lenses can be interchanged without altering the relative position of the focusing mechanism. It is always possible to use the range-finder even when the lens has been removed.

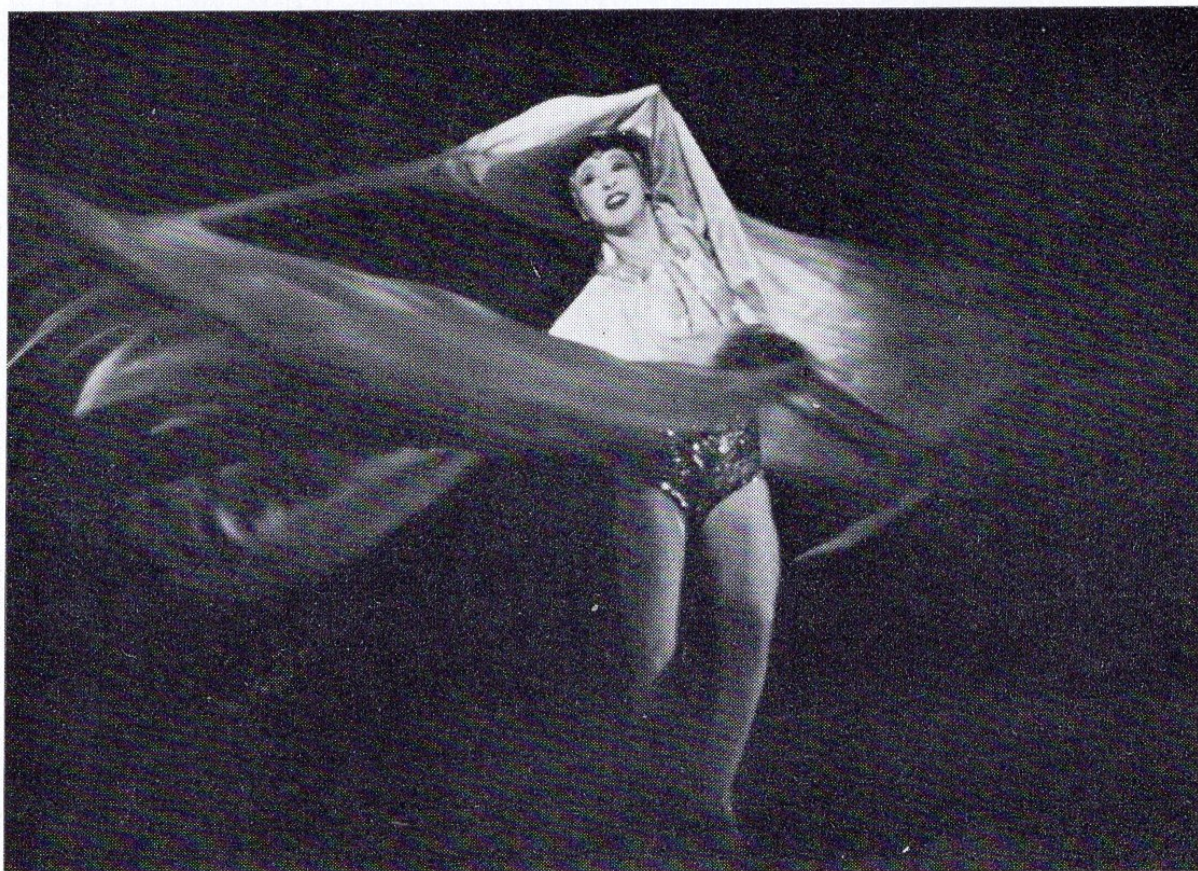

Example of CONTAX stage photography

Leo S. Pavelle

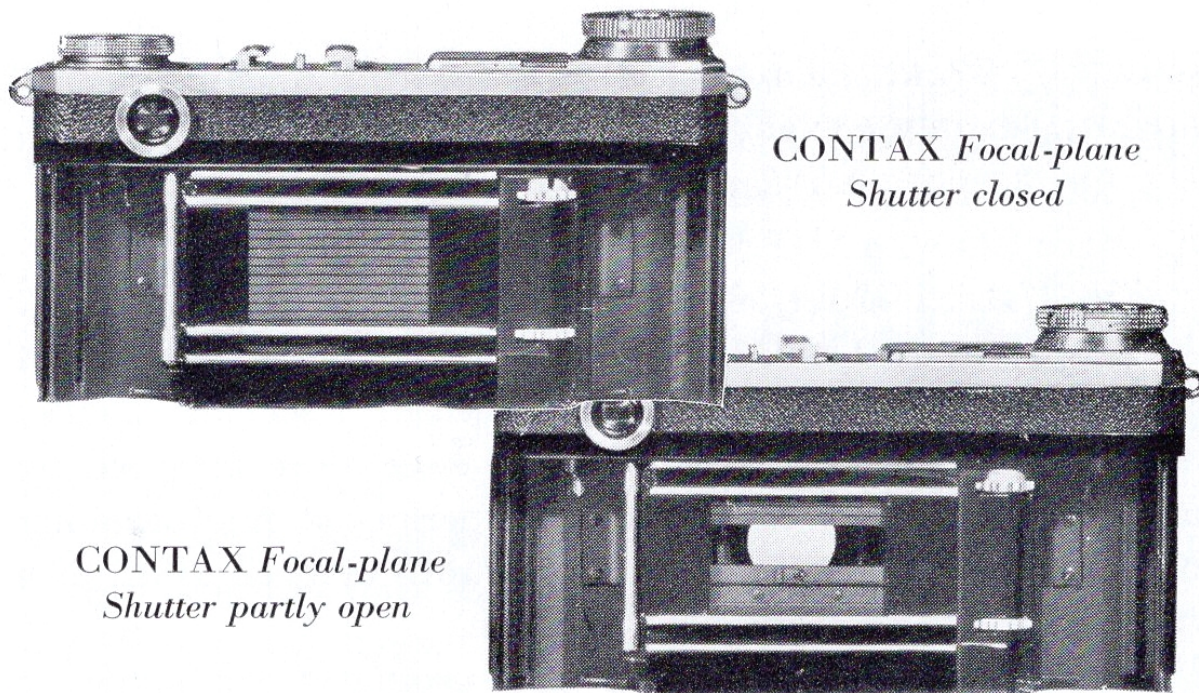

*CONTAX Focal-plane
Shutter closed*

*CONTAX Focal-plane
Shutter partly open*

The CONTAX All-metal Focal-plane Shutter

A truly universal camera such as the CONTAX must be equipped with a focal-plane shutter, for only a focal-plane shutter permits of the shortest possible exposure and the best possible use of the light entering the lens. The CONTAX shutter travels over the shortest distance of the film, vertically, thereby assuring even illumination of the negative.

The focal-plane shutter of the CONTAX is automatically coupled with the film mechanism so that the winding of the shutter automatically transports the film. This prevents accidental double exposures. However, when desired, any number of consecutive exposures may be made on the same negative.

The CONTAX shutter is the result of many years of scientific and technical research, both with regard to design and material. The material is a light metal with unlimited durability and a tremendously greater resistance to changes in temperature and climate, as well as to mechanical wear and tear, than a focal-plane shutter made of any other material.

The shutter consists of two metal blinds set with extreme

accuracy. The speeds of the shutter are:

for the CONTAX I (Black): 1/2, 1/5, 1/10, 1/25, 1/50, 1/100, 1/200, 1/500, and 1/1000th of a second, B and T.

for the CONTAX II (Chromium): 1/2, 1/5, 1/10, 1/25,

1/50, 1/125, 1/250, 1/500, and 1/1250th of a second, B and T.

At all speeds, the CONTAX metal shutter runs smoothly and quietly. Exposures at 1/25th or 1/50th of a second, camera held in hand, show a sharpness not heretofore attained by amateur photographers, and the experienced photographer may quite easily use exposures of 1/10th or even 1/5th of a second with the camera held in hand.

The first focal-plane shutter ever produced was made by C. P. Goerz, now merged in Zeiss Ikon. The long and highly specialized experience of Zeiss Ikon with the difficult problem of design and construction of focal-plane shutters, has resulted in the all-metal focal-plane shutter which is used in the CONTAX, and which embodies their knowledge, tradition, and standards.

Picture Aperture and Film Guide

To obtain a perfect negative, it is, of course, necessary that the film lie absolutely flat—as flat as a plate. In the CONTAX the film passes through an extremely shallow channel with a spring pressure plate on the reverse side of the film. It is held absolutely flat and in the focal-plane, which insures the sharpest negative possible.

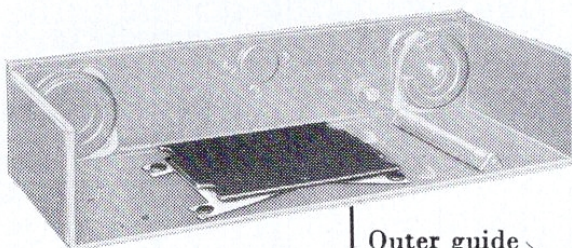

*Back cover of
CONTAX showing
pressure plate*

*Sectional diagram
of film channel*

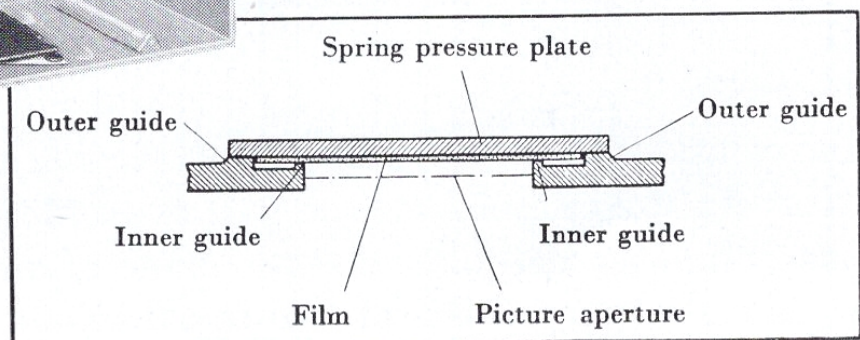

Film Loading

In the CONTAX - you use standard perforated 35 mm. motion picture film in lengths of approximately sixty-three inches. Each film spool gives thirty-six pictures of 24 x 36 mm., approximately $1\frac{5}{16}$ x $1\frac{3}{8}$ inches. The automatic exposure counter shows the number of exposures made.

Double exposures (except where deliberately intended) are completely eliminated by the automatic film transport

which, when winding the shutter, automatically transports the film necessary for the next exposure.

We recommend the use of CONTAX daylight loading spools with paper leader and paper trailer, which are inserted and removed from the camera in plain daylight in the same manner as you would load and unload any roll film camera. CONTAX daylight loading spools are supplied by the leading film manufacturers throughout the world.

When the photographer desires to use bulk film which is more economical and may be obtained in lengths of twenty-five to one hundred feet or to use shorter lengths of film, magazines are provided which may be loaded in the dark room with the requisite lengths of film. It is possible to use two magazines, winding the film from one magazine into the other, so that the film may be removed from the camera after any given number of exposures.



John A. Davis

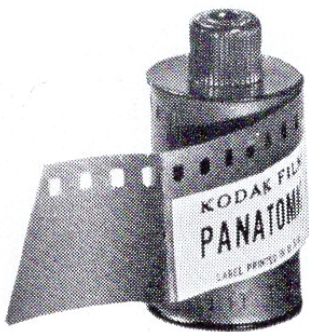

*Daylight
loading
spools*

Interchangeability of Lenses

For the CONTAX there are available thirteen lenses of various focal lengths and apertures, meeting the most exacting photographic requirements, and most of them are coupled with the range-finder.

The various Zeiss lenses available for the CONTAX are conveniently and quickly interchanged by means of a bayonet mount. This bayonet mount insures absolute focus as well as ease of operation. It takes but a second to change lenses. The bayonet mount with which the CONTAX is equipped is impervious to wear and tear, and the infinity point, represented by two red dots, remains the same no matter what lens is fitted to the camera. The only precaution necessary in changing lenses is to match the red dot on the mount of the lens with the two red dots—one on the focusing mount and one on the CONTAX body. This operation having been accomplished, accurate adjustment of the lens is assured.

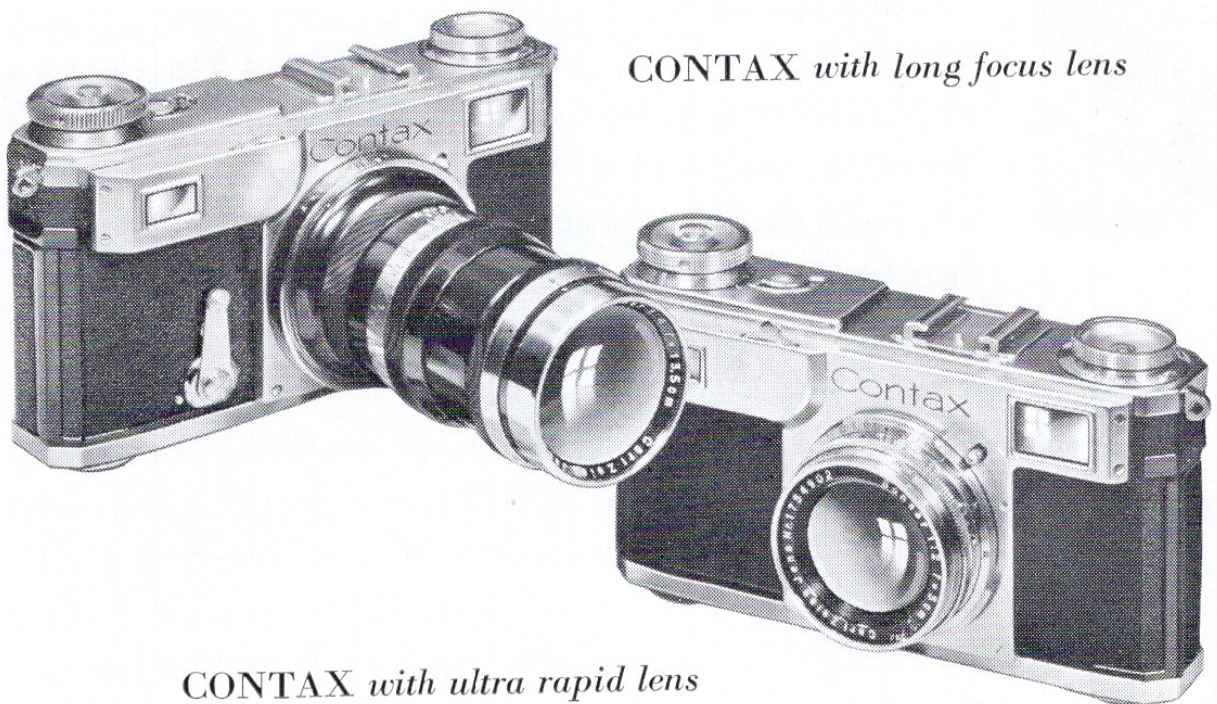

CONTAX with long focus lens

CONTAX with ultra rapid lens



Ten of the 13 CONTAX Lenses now available

CONTAX LENSES

The unrivaled results obtained with the CONTAX are due in a large measure to the fact that Zeiss lenses, famous throughout the world for their remarkable optical qualities, are employed. Altogether, thirteen lenses are available for the CONTAX, covering practically every requirement.

Universal Lenses

Tessar F/3.5 50 mm. (2 in.)	Sonnar F/2 50 mm. (2 in.)
Tessar F/2.8 50 mm. (2 in.)	Sonnar F/1.5 50 mm. (2 in.)

Long-distance Lenses

Triotar F/4 85 mm. (3 ³ / ₈ in.)	Tele-Tessar-K F/6.3 180 mm. (7 in.)
Sonnar F/2 85 mm. (3 ³ / ₈ in.)	Tele-Tessar F/8 300 mm. (12 in.)
Sonnar F/4 135 mm. (5 ³ / ₈ in.)	Tele-objective F/8 500 mm. (20 in.)
Sonnar F/2.8 180 mm. (7 in.)	

Wide-angle Lenses

Tessar F/8 28 mm. (1 ¹ / ₈ in.)	Biotar F/2 40 mm. (1 ⁹ / ₁₆ in.)
---	--

UNIVERSAL LENSES

Zeiss Tessar F/3.5 50 mm. (2 in.)

For all-round use and subjects which occur in every-day photography, first consideration should be given to the Tessar F/3.5 50 mm. This lens seldom needs to be stopped down and may also be used to great advantage as an enlarging lens. The Tessar F/3.5 50 mm. for the CONTAX represents an improvement on the previous Tessar types and is especially adapted to miniature cameras.

Zeiss Tessar F/2.8 50 mm. (2 in.)

This Tessar is similar to the preceding Tessar F/3.5 50 mm., in its excellent optical qualities at the same aperture. The larger aperture adds to the scope of this lens and makes it a truly universal objective.

Zeiss Sonnar F/2 50 mm. (2 in.)

The Sonnar type of lens is the most recent development in lens construction. Its outstanding feature, in addition to the large aperture, is its compactness. The entirely new design of the Sonnar lenses has helped to overcome the disadvantages which hitherto attended the manufacture of lenses of extreme aperture. The six components are so combined that pictures of excellent brilliance, sharp to the very edges, are assured. The Sonnar F/2 50 mm. is now available both in a rigid and a collapsible mount.

Zeiss Sonnar F/1.5 50 mm. (2 in.)

This super-speed lens has opened an entirely new field of photography — candid photography — in other words the photography of objects under unfavorable conditions. This is the lens recommended for indoor photography where short exposures are necessary. The seven lenses of this objective

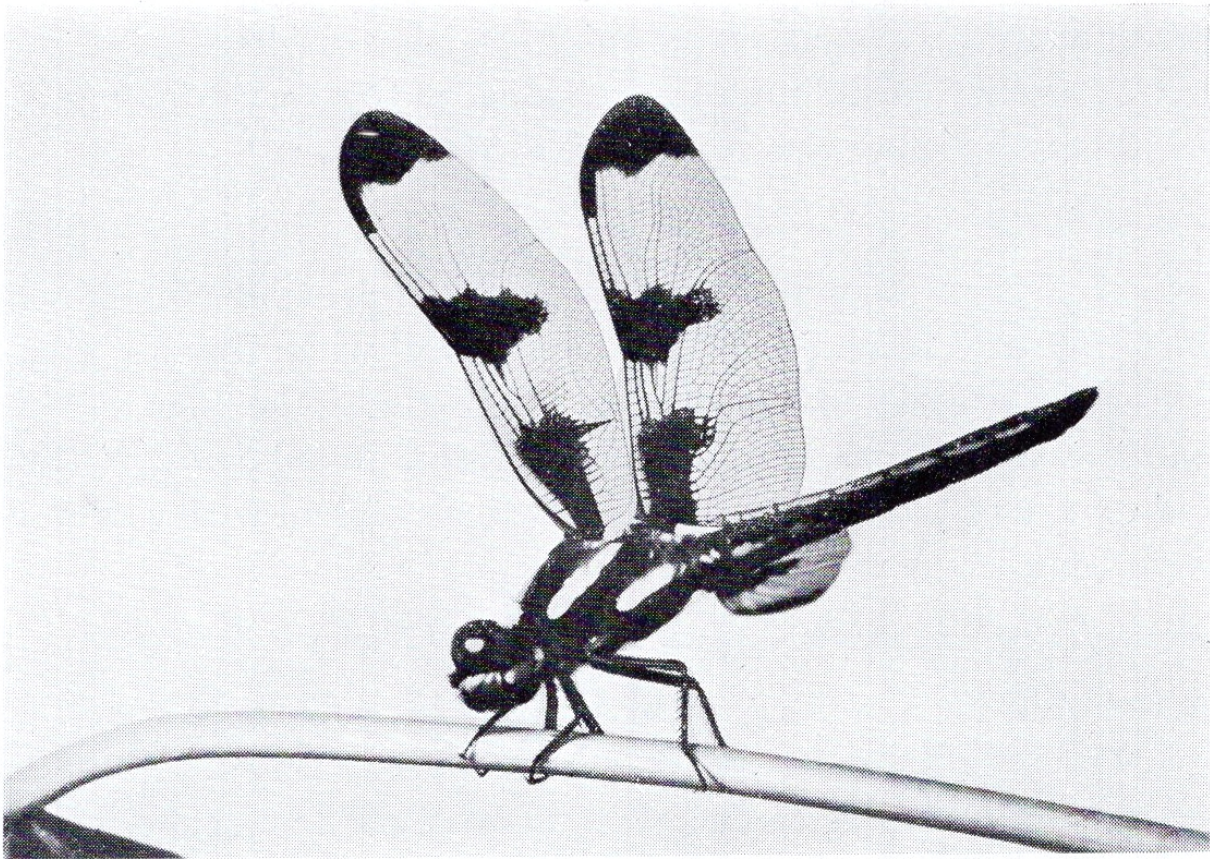

Dragonfly

Vernon E. Whitman

Made with CONTAX and Contameter

are so arranged that a flat field and critical definition to the margins are assured.

LONG DISTANCE LENSES

Zeiss Triotar F/4 85 mm. (3³/₈ in.)

This lens is very suitable for portraiture, in which a greater focal length has always been preferred. The Triotar F/4 85 mm. will give a very pleasing perspective in portraiture and at the same time may also be used as a medium telephoto lens for landscape work.

Zeiss Sonnar F/2 85 mm. (3³/₈ in.)

For press photography and portraiture under less favorable lighting conditions, the Sonnar F/2 85 mm. is very strongly

recommended. Negatives obtained with this lens have an extraordinary brilliance and are sharp to the very edges—the ideal lens for close-ups in stage photography.

Zeiss Sonnar F/4 135 mm. (5³/₈ in.)

This objective may justly be termed the premiere telephoto lens for all-round purposes. Compared with the 50 mm. lenses, it renders objects nearly three times the size at the same distance. Its outstanding feature, in addition to the comparatively large aperture, is flatness of field with extreme definition.

Zeiss Tele-Tessar-K F/6.3 180 mm. (7 in.)

With this lens of long focal length, long-distance work is greatly facilitated. In spite of the comparatively small angle covered, the lens is to be recommended for landscape work.

***Zeiss Tele-Tessar F/8 300 mm. (12 in.)
and Tele-Objective F/8 500 mm. (20 in.)***

Intended for extreme telephoto work, these lenses are used on a tripod, the camera being attached to them by means of the bayonet lock. A special optical view-finder with parallax adjustment is used for locating the subject to be photographed. These extremely long focal length lenses are ideal for the scientific photographer who wishes to cover unusual subjects at great distance.

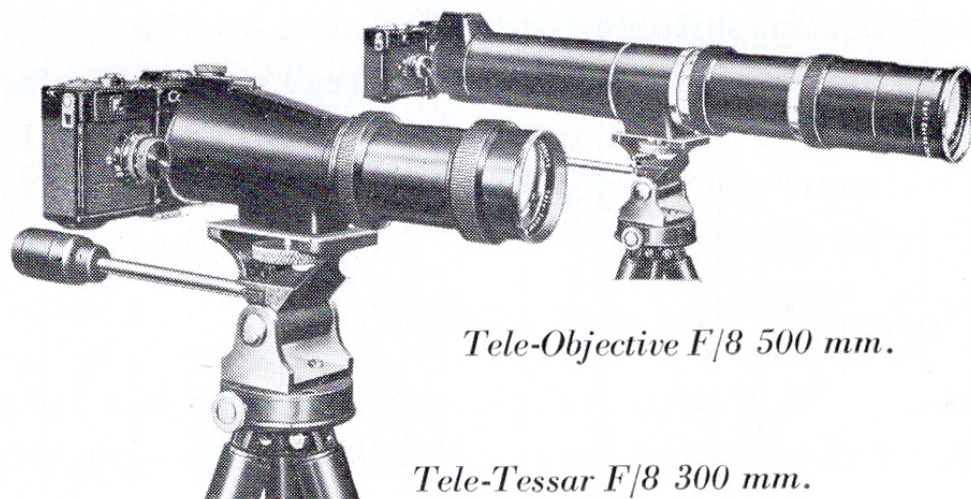

Tele-Objective F/8 500 mm.

Tele-Tessar F/8 300 mm.



28 mm.



40 mm.



50 mm.

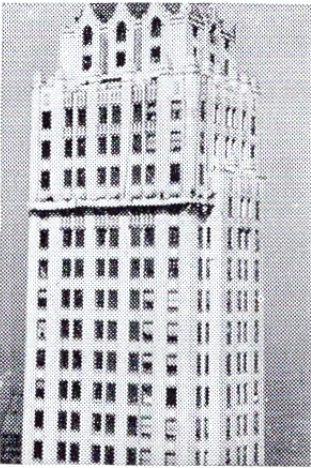

85 mm.

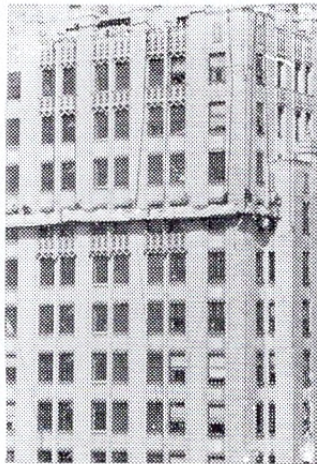

135 mm.

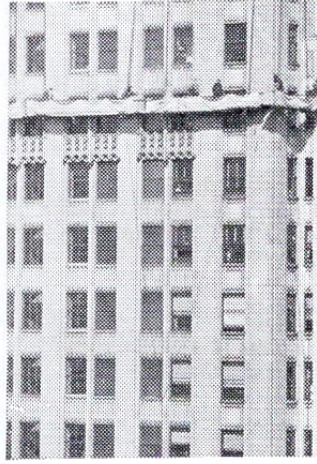

180 mm.

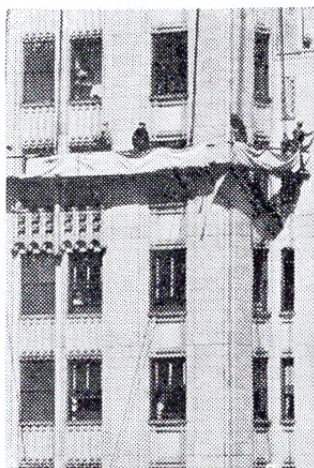

300 mm.

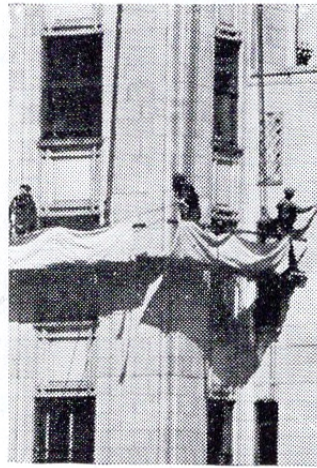

500 mm.

Photographs of same object taken with lenses of different focal lengths

Zeiss Sonnar

F/2.8 180 mm. (7 in.)

This is the last word in lens construction and represents an entirely modern telephoto lens of extremely large aperture. It is the press and sports photographer's lens, which will produce a cor-

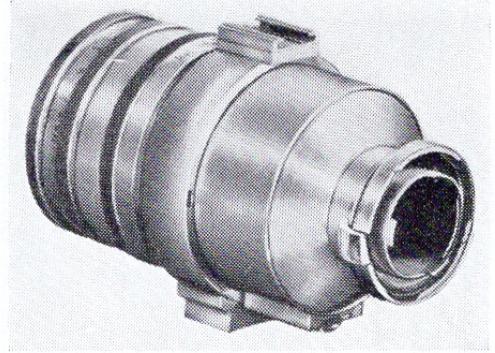

rectly exposed negative of fast moving objects, no matter what the lighting conditions may be.

WIDE ANGLE LENSES

Zeiss Tessar F/8 28 mm. (1 $\frac{1}{8}$ in.)

The Tessar F/8 28 mm. is an extremely wide-angle lens covering an angle of seventy-five degrees. The flatness of its field results in outstanding negatives, sharp to the very edges.

Zeiss Biotar F/2 40 mm. (1 $\frac{9}{16}$ in.)

This objective covers an angle of fifty-five degrees, and may be considered a wide-angle lens of the speed type.

SUPPLEMENTARY LENSES

Proxar supplementary lenses by decreasing the focal length of the 50 mm. lenses permit close-up photography. They are used at given distances and permit you to focus as close as 12 inches.

ENLARGING AND PROJECTION

All 50 mm. (2 in.) lenses provided for the CONTAX are suitable for use in the enlargers, copying apparatus, and projectors. The Sonnar F/1.5 is somewhat less suited to these uses because it is essentially a super-speed lens rather than a universal lens.

A special, moderately priced anastigmat is available for use in the enlarging devices.

VIEW-FINDERS

A built-in view-finder is an integral part of the CONTAX camera. In addition, a number of special view-finders aiding in picture taking, are available.

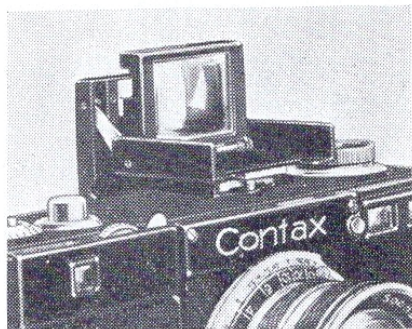

Albada View-finders

The special feature of this new type of view-finder is the fact that the image is shown as seen normally with the eye. This means that one can use both eyes, as the image seen through the Albada View-finder corresponds to that seen by the other eye. The Albada Sports Finder is especially suited for taking fast moving objects. The image is seen in unreversed position. In addition to the Albada Sports Finder for 50 mm. lenses, there are available two other Albada Finders for use with different focal length lenses, one for 50 and 85 mm. and one for 50 and 135 mm. The front glass is slightly silvered on the inside and by reflection a white border line is shown giving the correct field for a particular focal length lens.

Universal Revolving View-finder

The Universal Revolving Finder is a precision optical instrument. It covers the focal lengths of 28, 50, 85, 135, and 180 mm., or 28, 40, 50, 85, and 135 mm. In this revolving view-finder the image is shown right side up, for each of the focal length lenses given, for close-up and infinity, and with the parallax carefully taken care of. For the amateur owning a variety of lenses, this revolving view-finder may be recommended as a valuable and efficient adjunct.

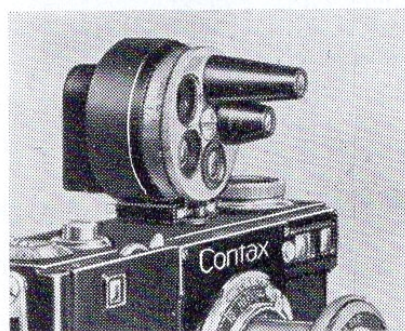

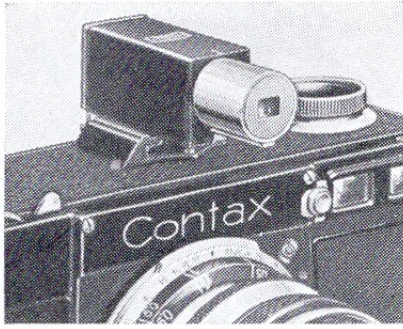

Multiple View-finder

The Multiple Finder is a telescopic finder for the focal lengths of 50, 85, 135, and 180 mm. The field is shown right side up, both for infinity and close-up.

Vertical Telescopic View-finder

The Vertical Telescopic Finder is a small finder of great brilliance, which shows an unreversed image for 50 mm. lenses. It is particularly useful when taking pictures of children, as it enables the photographer to hold the camera at a lower level. It may also be used at right angles to the direction in which the camera appears to be held.

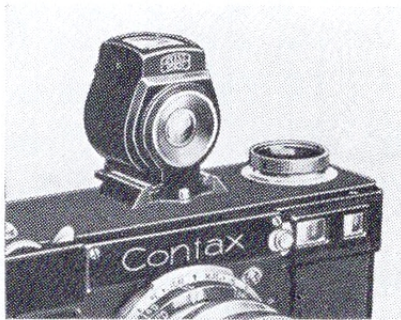
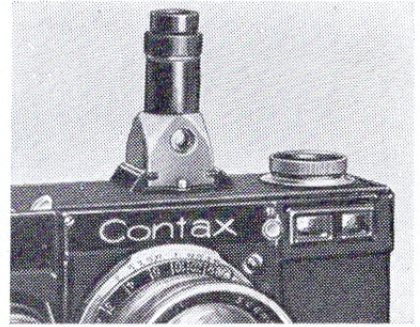

Brilliant Prism View-finder

The Brilliant Prism View-finder is used at low level and at right-angles. It is held at a distance from the eye for distant viewing.

Wide-angle View-finders

Wide-angle view-finders showing the correct field for either the 28 mm. or the 40 mm. lenses are available, as well as

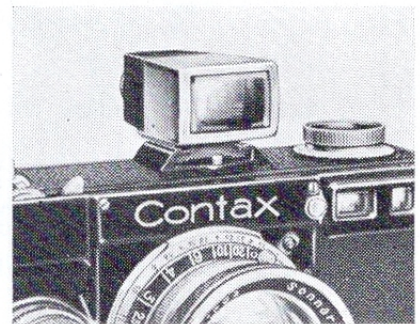

Special Tele View-finders

for the 180, 300, and 500 mm. lenses, the finders for the last two lenses being fitted with an extremely accurate parallax adjustment.

CONTAX ACCESSORIES

The CONTAX camera is a foundation upon which an entire system of photography can be built up, covering all photographic requirements.

Accessories are available for enlarging, for reproduction work of every description, for photomicrography and close-up work. For example, the Zeiss Ikon Contameter for close-up photography represents a lens system permitting the use of the CONTAX without an elaborate set-up.

A complete listing of the accessory equipment for the CONTAX is found in the following pages.

Contax Plate Back

The construction of the CONTAX permits the use of a plate back. The plate back is interchangeable with the standard removable back of the camera and is so constructed that both plates and cut film of 30 x 45 mm. ($1\frac{1}{8}$ x $1\frac{3}{4}$ in.) may be used. Focusing is done on an insert ground glass.

This plate back is especially useful in scientific and research photography where it is desired to see the composition of the image and check up on its definition before taking the actual picture. A large variety of sensitized material is available, and any standard 9 x 12 cm. or $6\frac{1}{2}$ x 9 cm. plate or cut film may be conveniently cut to size.

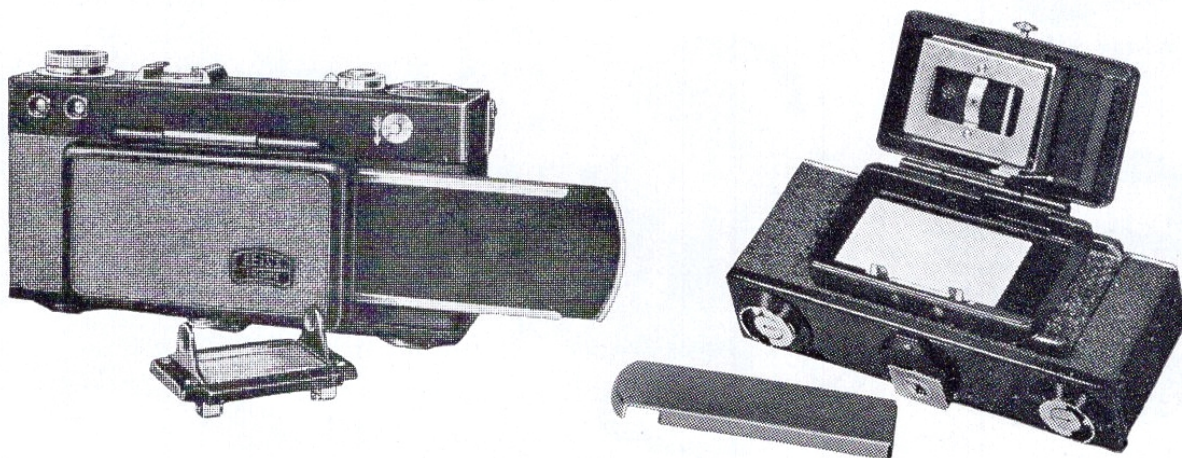

CONTAX plate back for plates and cut film

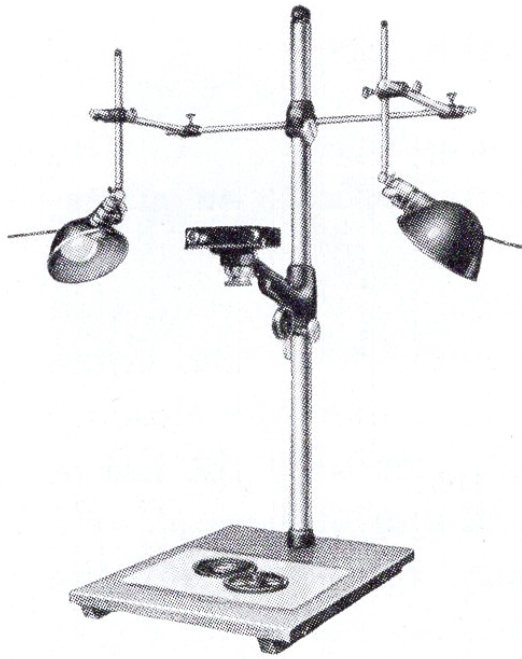

Large copying stand with illuminating apparatus

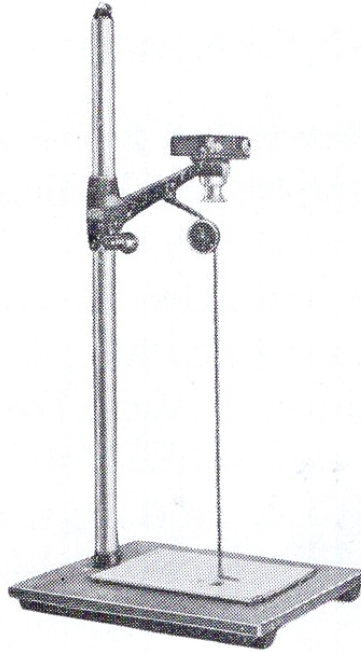

Large copying stand

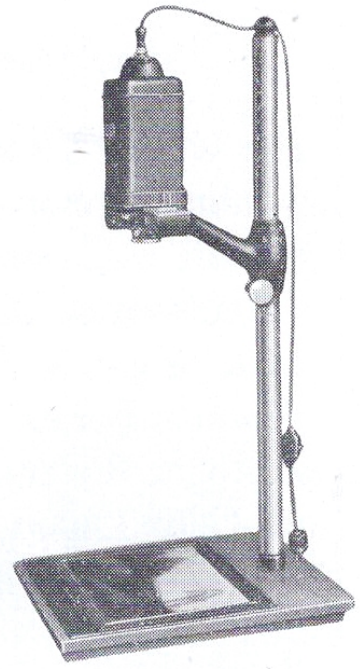

Magniphot enlarger

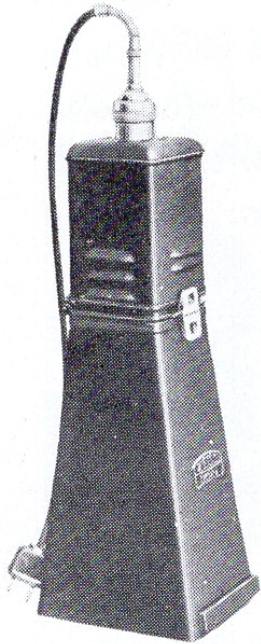

Helinox printer

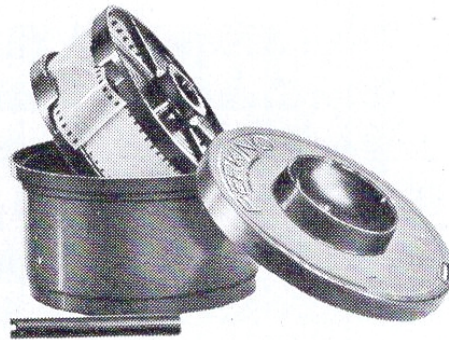

Developing tank

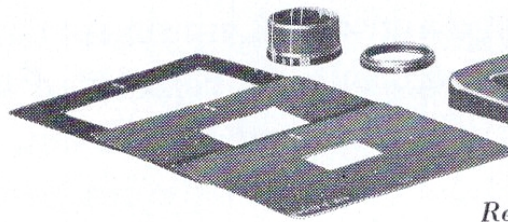

Reproduction stand

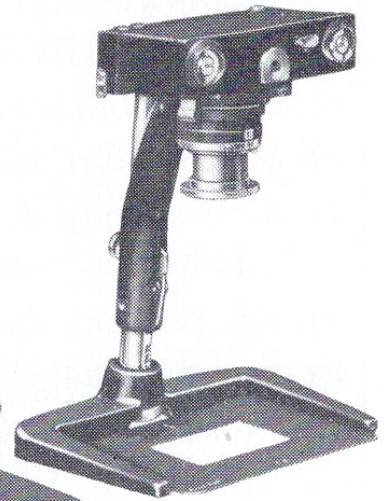

Ground glass screen adapter

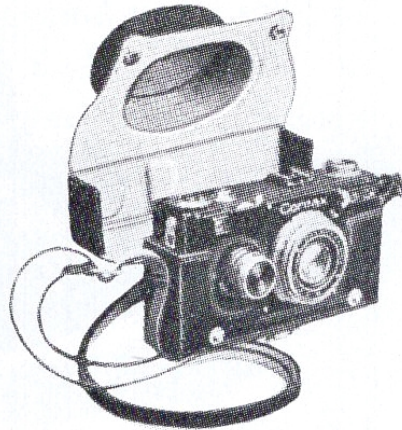

Eveready carrying case

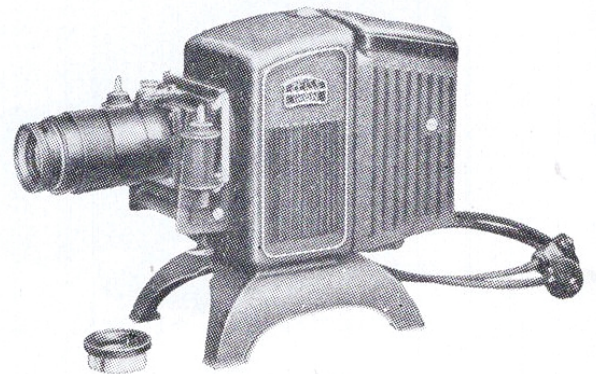

Projector

SUPPLEMENTARY CLOSE-WORKING ATTACHMENTS

Optical near-focusing device "Contameter," comprising a special viewing-range-finder with three interchangeable range-finder objectives and three matching supplementary lenses fitting 50 mm. Contax lenses; permitting photography at distances of 10", 15" and 20"; 1343/0.

Proxars for inner mount fitting only 50 mm. Tessars, 1x27, working distances from 3'7" to 1'8½". 2x27, working distances from 1'11" to 1'3".

Proxars, fitting either 50 mm. Tessars or Sonnars, 1x42, working distances from 3'4½" to 1'8½". 2x42, working distances from 1'9½" to 1'2¼".

Adjustable extension tube set comprising 4 threaded graduated rings, rear mount with bayonet-lock and front mount with bayonet-lock, capable of giving up to 2¼x mag. with 50 mm. lens.

SUNSHADES

Regular sunshades are available for all lenses.

For Tessar F/8, 28 mm., special sunshade, 1283/2.

Collapsible sunshade for 50 mm. lenses, 1283/3.

Adapter for using above with 135 and 180 mm. lenses, 1283/11.

FILTERS

Carl Zeiss light or dark yellow.

Zeiss Ikon light, med., or dark yellow.

Zeiss Ikon ultra-violet.

Zeiss Ikon graduated yellow sky filter.

Zeiss Ikon green.

Zeiss Ikon yellow-green.

Zeiss Ikon orange.

Zeiss Ikon light red.

Zeiss Ikon medium red.

Zeiss Ikon dark red.

Zeiss Ikon infra-red (black).

Intermediate ring adapting 42 mm. filters to 37 mm. mounts.

VIEW-FINDERS

For wide-angle Tessar F/8, 28 mm., 432/3.

For wide-angle Biotar F/2, 40 mm., 432/4.

For Tele-Tessar K F/6.3, 180 mm., 436/11.

Albada sports finder for 50 mm. lenses only, 433/24.

Albada sports finder for 50 and 85 mm. lenses, 433/25.

Albada sports finder for 50 and 135 mm. lenses, 433/26.

Multiple finder for 50, 85, 135 and 180 mm. lenses, 436/1.

Universal revolving finder for 28, 50, 85, 135 and 180 mm. lenses, 436/4.

Brilliant low-level waist finder for 50 mm. lenses only, 436/5.

Oblique sighter (60° angle finder), 436/3. (for Contax I only)

Vertical telescopic and angle finder for 50 mm. lenses only, 436/2.

Holder for spectacle lenses, fitting over view-finder and range-finder Contax sights. Special lenses should be obtained from local opticians on prescription. Holder, 540/12.

LEATHER CARRYING CASES

Soft pouch to fit Contax with 50 mm. Tessar.
Soft pouch to fit Contax with 50 mm. Sonnar.
Eveready case to fit Contax with 50 mm. Tessar.
Eveready case to fit Contax with 50 mm. Tessar and Albada.
Eveready case to fit Contax with 50 mm. Sonnar.
Eveready case to fit Contax with 50 mm. Sonnar and Albada.
Reinforced rectangular case to fit Contax with 50 mm. lens.
Reinforced round case for 50 mm. lens, 1777/14.
Reinforced round case for 85 mm. Sonnar F/2, sunshade and filter, 1777/7.
Reinforced round case for 85 mm. Triotar F/4, sunshade and filter, 1777/6A.
Reinforced round case for 135 mm. Sonnar F/4, sunshade and filter, 1777/6.
Universal case for Contax I (black) with 50 mm. lens, wide-angle Tessar, filters, supplementary lens, magazines, daylight-loading roll film and one telephoto lens, 1777/3.

TRIPODS AND TRIPOD PARTS

Tabletop and chain tripod, 1624/10.
Unipod single-legged telescoping support, 1624/11.
Tilting tripod head, 1630/2.
Ball and socket swivel tripod head, 1628/10.
3-section wooden tripod, 1672/5.
Intermediate extension piece for tripod when using Contax in Eveready case, 1628/11.

PLATE BACK ADAPTER AND ACCESSORIES

Contax plate back (specify for which model), using 3 x 4.5 cm. plates, complete with one holder, 540/13.
Extra plate holder, 540/14.
Sheath (wedge-plate) for using cutfilm with plate back, 540/8.
Template for cutting 3 x 4.5 cm. plates from large sizes, 2006/1
Insert ground glass focusing screen, 540/11.

PROJECTION APPARATUS

Large Contax projector for diapositive strips and 2" x 2" slides, complete with condensor, 250 watt projection bulb, water-jacket cooling

system and special objective Alinar F/2.5, 10 cm. with removable front element for which an Agfa color element, also included, may be substituted. Contax lenses need not be used.

PHOTOMICROGRAPHIC ATTACHMENT

Phoku-Contax, for photography through a microscope, with bayonet-lock for attaching Contax body (no Contax lens necessary).

ENLARGING APPARATUS

Magniphot enlarger, complete with column, baseboard, condenser, bulb and clamp-down negative lever, but without lens, 1455.

Magniphot, as above, but with special projection anastigmat.

Opal bulb 60W-110V (75W-125V) for Magniphot, 1557/49.

Red filter attachment for Magniphot.

Glass sheets for wet negative projection, 1455/22.

Helinox-Contax fixed-focus (to 9 x 12 cm.) enlarger, 1411/7.

Frosted bulb for Helinox 40W-110V (50W-125V).

Focusing mount for using 50 mm. screw-in (without bayonet-lock) lenses in Magniphot, 1454/23.

Intermediate ring with bayonet-lock for using 50 mm. Contax lenses with enlargers having screw-in mounts, 1454/31.

Metal paper-holders (hinged):

For paper 2½" x 3½" (6.5 x 9 cm.)	For paper 5" x 7" (13 x 18 cm.)
For paper 3¼" x 4¼" (8 x 10.5 cm.)	For paper 7" x 9½" (18 x 24 cm.)
For paper 4" x 6" (10 x 15 cm.)	For paper 9½" x 12" (24 x 30 cm.)

REPRODUCTION AND COPYING APPARATUS

Reproduction stand, complete with rings and masks, for copying in ratios 1:1 to 1:4, 5520/1.

Wooden box for above, 5520/0.

Reproduction bracket for use with column and baseboard of Magniphot enlarger, for copying in ratios 1:1.6 to 1:14 (objects from about 1½" x 2" to 13½" x 20"), 1454/25.

Lighting equipment for use with reproduction bracket on Magniphot column, 1454/27.

Set of 2 additional reflectors with attachment clamps, 1454/37.

Baseboard and column for reproduction bracket (as with Magniphot), 1454/28.

Set of 3 Delta lenses required when 50 mm. Sonnar is used with reproduction bracket, 995/32.

Ground glass focusing screen with bayonet-lock, for use with reproduction stand or reproduction bracket, 5520/6.

Slip-on focusing screen magnifier and light-exclusion hood, 5520/7.

VIEWING MAGNIFIERS

Viewing magnifier with film-notching device and bulb and cable for attachment to light socket.

Hand magnifier with clamp collar focusing lock, mag. 6x.

Hand magnifier with clamp collar focusing lock, mag. 10x.

Hand magnifier with sliding sleeve, mag. 6x.

Hand magnifier with sliding sleeve, mag. 10x.

MISCELLANEOUS

Autex self-timing automatic release, 1394/6.

Cable release for time and instantaneous exposures, 1312/24.

Liliput printing frame for single 24 x 36 mm. negative, 2643/24.

Neck strap for the Contax.

Spirit level, 888/1.

Perkino developing tank.

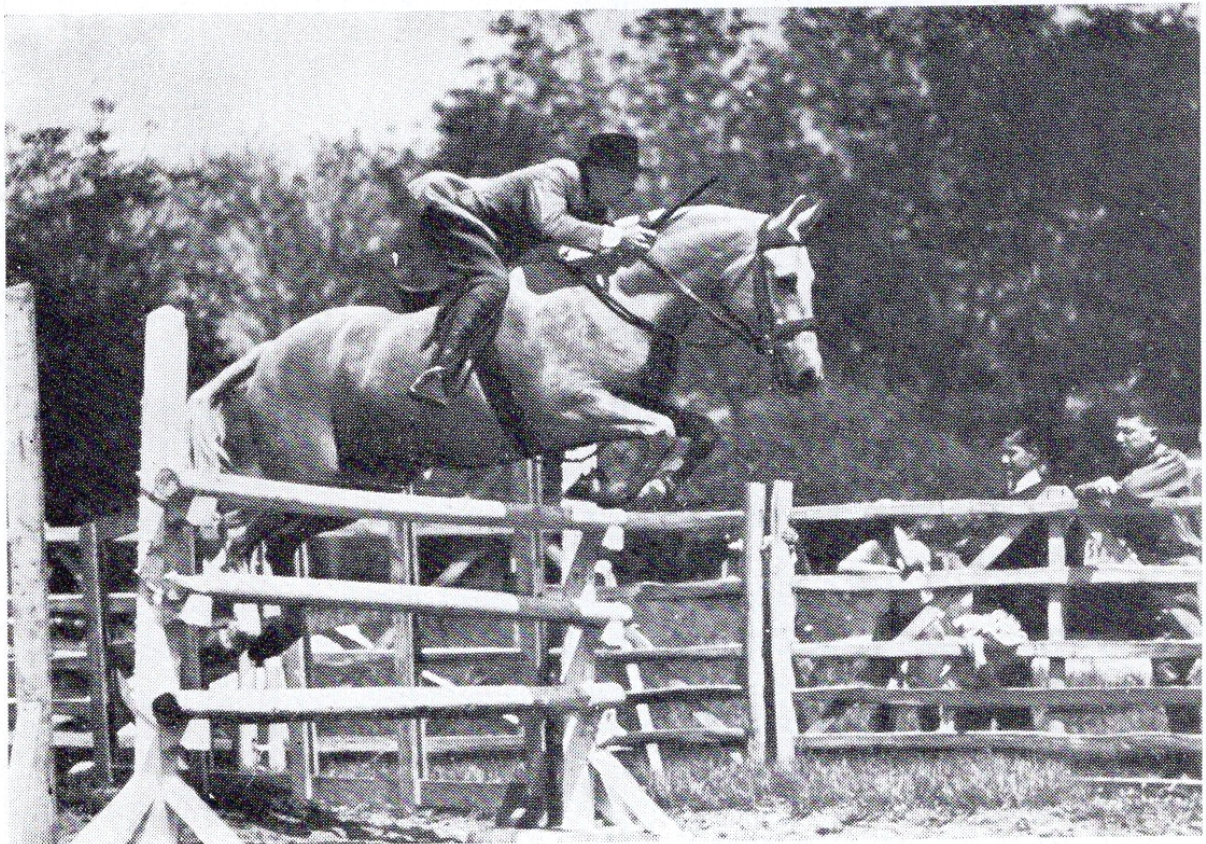

Sonnar F/2-8.5 cm. 1-1000 sec. F/2

Fenwick G. Small



Bob Leavitt



CONTAX PHOTO, TONI FRISELL

CARL ZEISS, Inc.
485 FIFTH AVENUE, NEW YORK
728 So. Hill St. Los Angeles

C-65-936



Printed in U. S. A.

Zeiss Ikon Cantax Zeiss Lenses Prospekt 1936 EN

 [01.jpg](#)

 [02.jpg](#)

 [03.jpg](#)

 [04.jpg](#)

 [05.jpg](#)

 [06.jpg](#)

 [07.jpg](#)

 [08.jpg](#)

 [09.jpg](#)

 [10.jpg](#)

 [11.jpg](#)

 [12.jpg](#)

 [13.jpg](#)

 [14.jpg](#)

 [15.jpg](#)

 [16.jpg](#)

 [17.jpg](#)

 [18.jpg](#)

 [19.jpg](#)

 [20.jpg](#)

 [21.jpg](#)

 [22.jpg](#)

 [23.jpg](#)

 [24.jpg](#)

 [25.jpg](#)

 [26.jpg](#)

 [27.jpg](#)

 [28.jpg](#)