



ZEISS
IKON

CAMERAS



Whatever your subject, a Zeiss Ikon camera will always give you a good picture. Zeiss Ikon cameras offer many advantages: the built-in exposure meter for example, which is made in our own factory and backed by twenty years' experience! Progress and tradition combine to bring you the very latest in high-grade German cameras. For decades Zeiss Ikon products have been the embodiment of highest optical and mechanical precision throughout the world. There is a Zeiss Ikon camera to suit everyone: in all price ranges, for every kind of picture and for all film sizes. They are described in the following pages.



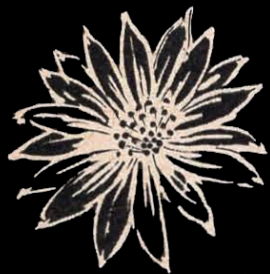

Here is what Zeiss Ikon has to offer:

35 mm CAMERAS

Contina	Page 4-5
Contaflex	6-8
Contax	10-11

ROLL-FILM CAMERAS

Nettar	12
Signal Nettar	12
Nettax	13
Super Ikonta	14
Ikoflex, Ikoflex Favorit	16-17

ACCESSORIES

Ikophot Rapid	15
Ikoblitz (Flashgun)	15
Filters,	
Lens hood, etc.	18
Ikolux (Projectors)	19
Stereo equipment	9

MOTION-PICTURE EQUIPMENT

Movikon 8 (8 mm camera)	20-21
Movilux 8 (8 mm Projector)	22
Moviphon (Tape recorder)	23

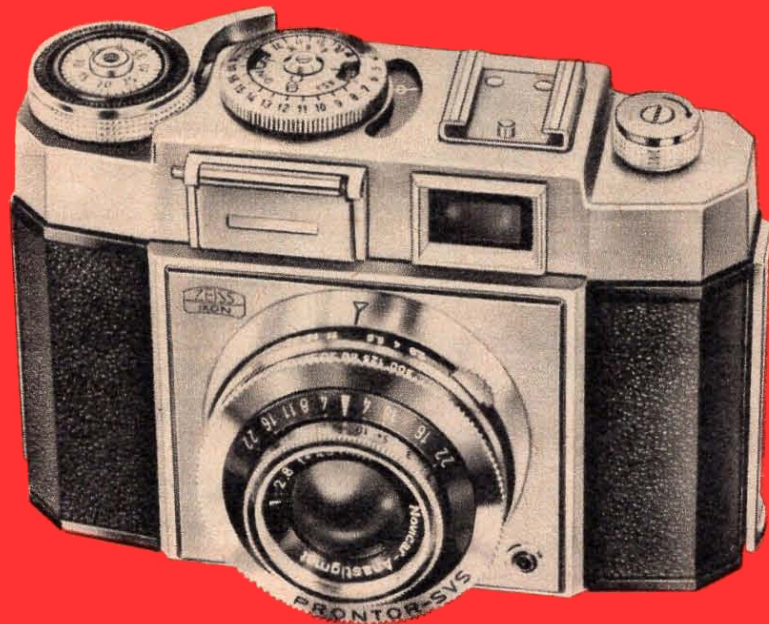

Contina II with exposure meter

Contina I and II 35 mm

You want pictures without a lot of fuss beforehand. This ever-ready miniature camera is the right choice for you. A thrust stroke of the rapid winding lever cocks the shutter and winds the film. The built-in Rapid photo-electric exposure meter gives the correct exposure value settings. A gentle pressure with the finger and the fleeting moment is captured for ever. All types of flash can be used, there is a delayed action release, exposure-value shutter speeded to $1/300$ sec. and wide-aperture lenses. The ideal camera for colour shots, too.

Contina II: Novar f/3.5, Prontor-SVS
Novicar f/2.8, Prontor-SVS

Order No. 527/24 Fpms
Order No. 527/24 Vpms

Contina I: as II, but without exposure meter
Novar f/3.5, Prontor-SVS

Order No. 526/24 Fpms

The Contina III System 35 mm

With the Contina III you can take pictures anywhere. With the telephoto lens you bring your neighbour's apple tree closer; with the wide-angle lens you can shoot in confined spaces indoors. And if you want a record of your friends in 3-D, the Stereo attachment will get it for you. The lens units can be interchanged by a turn in the bayonet mount. There are the same features as on the Contina II: exposure meter, rapid winding lever, delayed action release, etc.

Contina III: Pantar f/2.8-45 mm, Prontor-SVS Order Nr. 529/24 Gpms
Interchangeable lens elements: Pantar f/4-30 mm (Order No. 1001),
Pantar f/4-75 mm (Order No. 1002), Steritar-D complete (Order No. 814).

For special finders and further accessories see separate prospectus.



Contina III with Pantar 75 mm
and telephoto view and rangefinder

Contaflex I and II 35 mm

The miniature camera with the "magic finder"! You glance through it and this is what you see: the subject in nearly natural size, brilliantly clear, laterally correct and always sharply outlined, and in addition the images of a coupled rangefinder and a ground glass. Then there are these additional features: springloaded pre-selector iris diaphragm, delayed action release, XM-synchronized shutter speeded to $1/500$ sec., world-famed Zeiss lens, provision for use of two cassettes (important for colour film!), Model II with Rapid exposure meter.

Order No.

Contaflex II: Tessar f/2.8, Synchro-Compur MXV 862/24 Pcms
Contaflex I: as Modell II but without exposure meter 861/24 Pcms
Zeiss Ikon Teleskop 1.7x (Order No. 861/03). Accessories for stereo, copying work and photomicrography see pages 8 & 9.

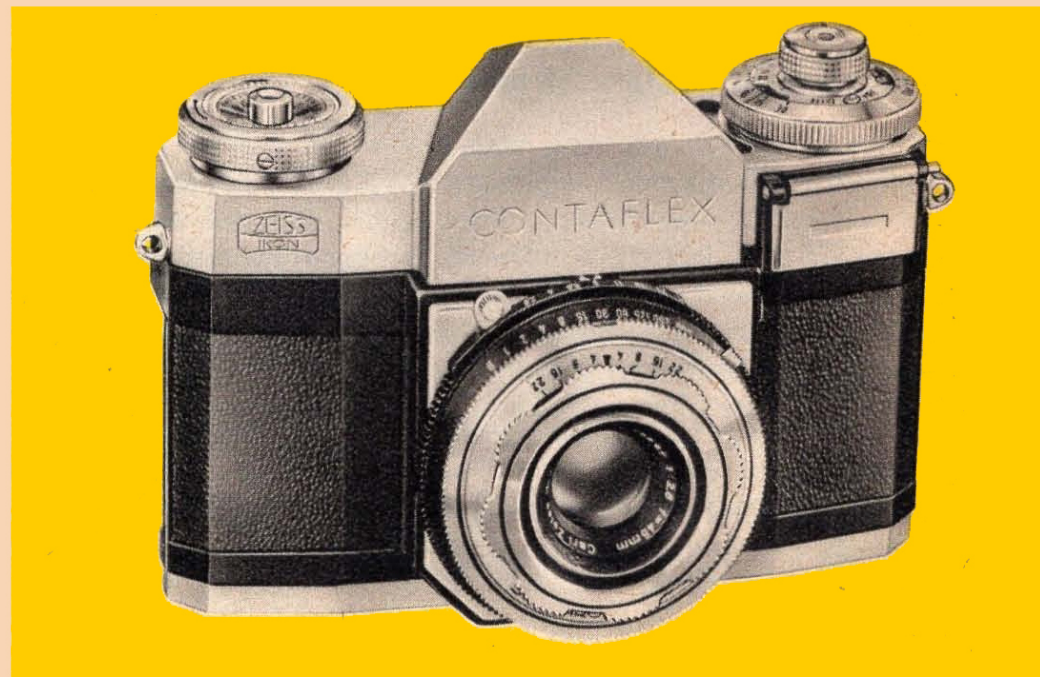

Contaflex II with exposure meter

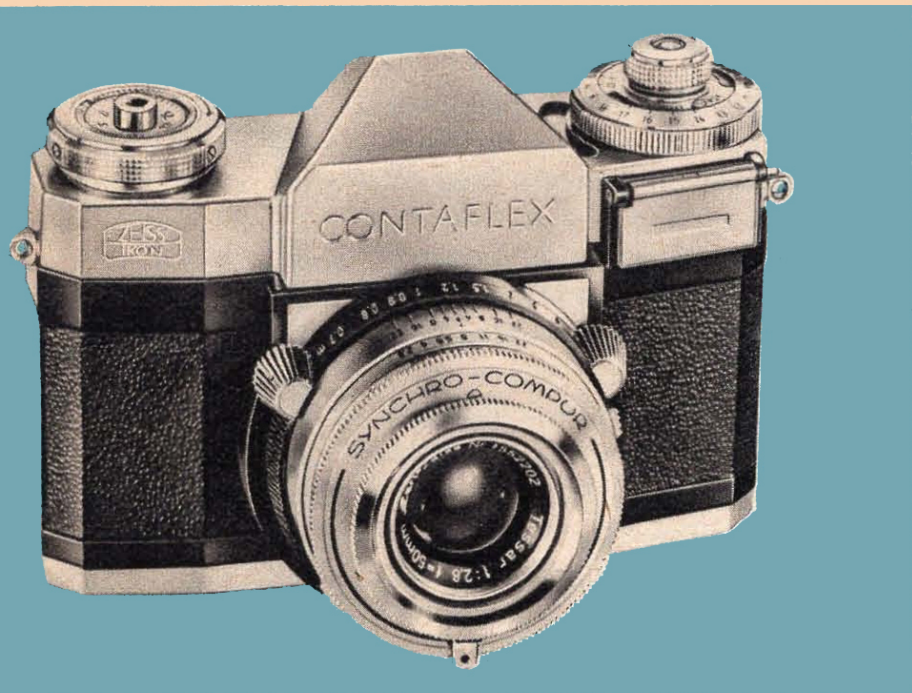

Contaflex IV with exposure meter

Contaflex III and IV 35 mm

A further development of the world-famed Contaflex series, with the ingenious brilliant finder that shows the correct field of view with all lenses. The Contaflex models III and IV (IV with Rapid exposure meter) have a Tessar convertible lens: the front element, which is bayonet-mounted, can be removed by a turn of the hand and replaced by telephoto, wide-angle or stereo unit. The outstanding performance of these Zeiss lenses, especially for colour shots, will amaze you. Focusing is controlled in the finder. The shutter has exposure-value settings and a flash control with safety lock.

Order No.

IV: Convertible Tessar f 2.8, Synchro-Compur 864/24 Ucms

III: as model IV but without exposure meter 863/24 Ucms

The next page gives more details of the Contaflex System.



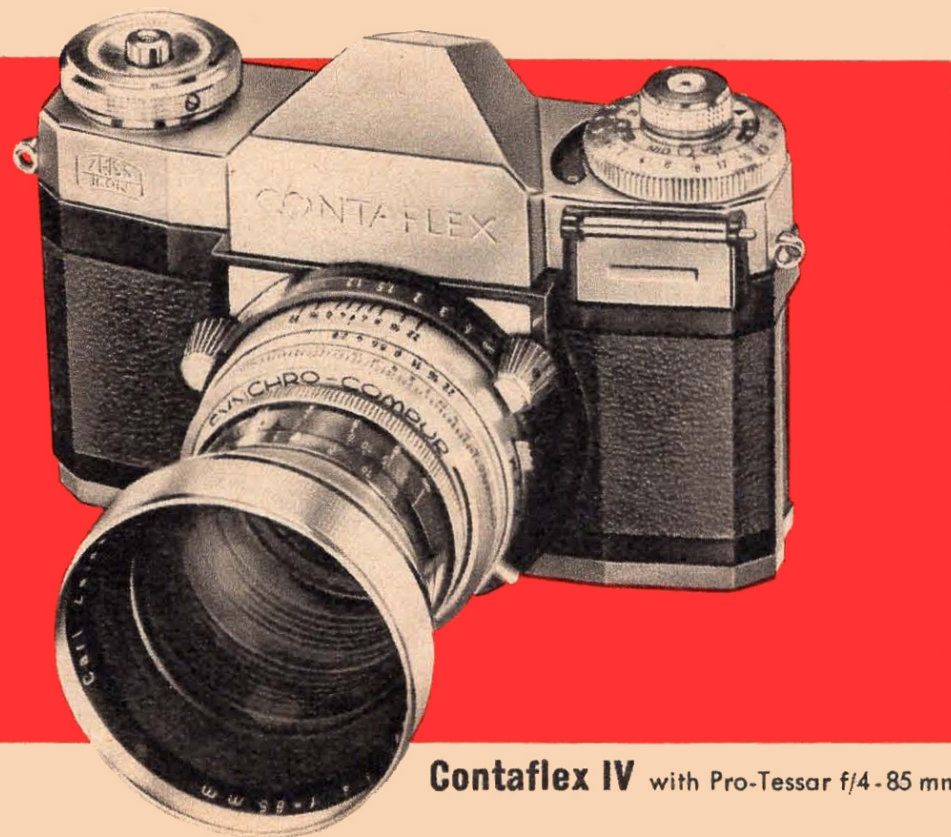

Contaflex IV with Pro-Tessar f/4-85 mm

The Contaflex System

This is where the Contaflex scores: no matter which lens you use, the brilliant finder always shows the correct field of view and a focusing image. And this applies with close-ups (down to 6.25 inches), stereo and copying work, and photomicrography. Separate finders are unnecessary.

For Contaflex III and IV:

Pro-Tessar f/4-35 mm. Order No. 1003

Pro-Tessar f/4-85 mm. Order No. 1004

For all four Contaflex models:

Zeiss Proxar supplementary lenses (for close-ups down to 20, 12, 8 $\frac{3}{4}$ and 6 $\frac{1}{4}$ inches) Order No. 909. For accessories for copying and photomicrography see separate prospectus.

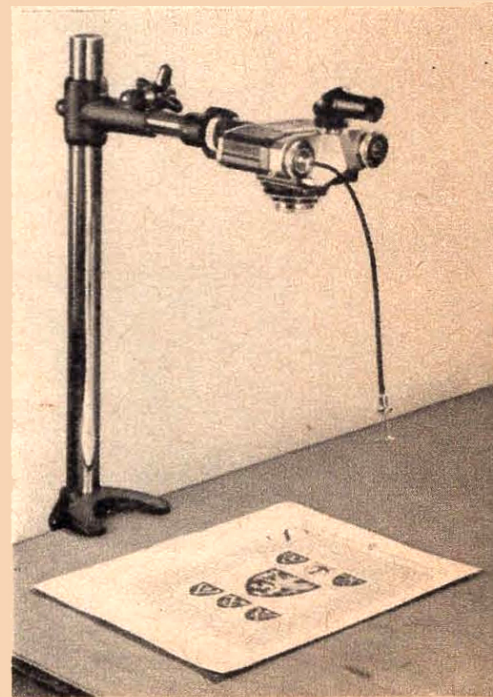

Contaflex with right-angle viewfinder
on table copying device

The Zeiss Ikon Stereo System

You can have no idea of the fascination of Stereo pictures until you actually see them. Your dealer will gladly arrange it. The Zeiss Ikon System now makes stereo work very easy. You convert your camera with a few simple manipulations, then you can take ordinary and stereo shots on the same film – in colour too of course – in any order you like. Zeiss Ikon equipment has one important advantage: all elaborate mounting is dispensed with; you just mount the pair of Stereo images, uncut, like any normal transparency. The Stereo viewers then give an excellent three-dimensional image. But projection is even more effective. No special projector is necessary here either: the Ikolux 150, 300 or 500 (see page 19) is merely fitted with an attachment. Handling remains the same. Just give it a try! There are Stereo attachments for the **Contina III**: Steritar-D, Order No. 814, **Contaflex III and IV**: Steritar-B, Order No. 813, **Contaflex I and II**: Steritar-A, Order No. 812, **Contax IIa and IIIa**: Stereotar-C, Order No. 810. Stereo-viewer for Steritar pictures, Order No. 1427, for Stereotar pictures, Order No. 1428. Stereo Attachment for Ikolux 150 and 300 in preparation, for Ikolux 500, Order No. 1479/01. Details of additional accessories on application.

ZEISS
IKON



Contaflex I with Steritar-A

Stereo viewer

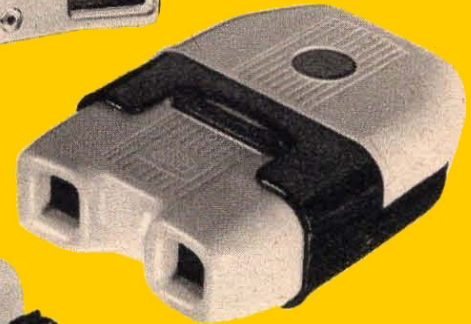

Ikolux 300
with Stereo Attachment

Contax II a and III a 35 mm

Here is the queen of the Zeiss Ikon cameras. Two fingers are all you need to work the Contax: the middle finger for focusing and the index finger to press the shutter release. Just a glance through the combined range and view finder, and there is your subject framed and focused. Never mind how fast that racing car is: the metal focal plane shutter can manage any speed up to $\frac{1}{1250}$ sec. And if you want to use flash, it is fully synchronized. Other important features are the removable back and the two-cassette system for rapid change-over from black & white to colour film in daylight, delayed action release, coupling of film transport and shutter-winding and a range of world-famed Zeiss lenses with apertures up to f/1.5.

The Contax System

From a raindrop to a skyscraper, from a snail to a racehorse: the Contax can tackle any assignment with its interchangeable lenses, from the unique f/4.5-21 mm Biogon with its 90° acceptance angle to the telephoto lenses, the wide range of special attachments for close-up work, copying and photomicrography, and last but not least the stereo attachment with accessories for close-ups down to $2\frac{3}{8}$ inches. That shows how versatile the Contax is. Ask your dealer for the special prospectus.

Contax	II a III a (with exposure meter)	
With Zeiss Tessar f/3.5-50 mm	563/24 L	564/24 L
With Zeiss Sonnar f/2 -50 mm	563/24 N	564/24 N
With Zeiss Sonnar f/1.5-50 mm	563/24 J	564/24 J



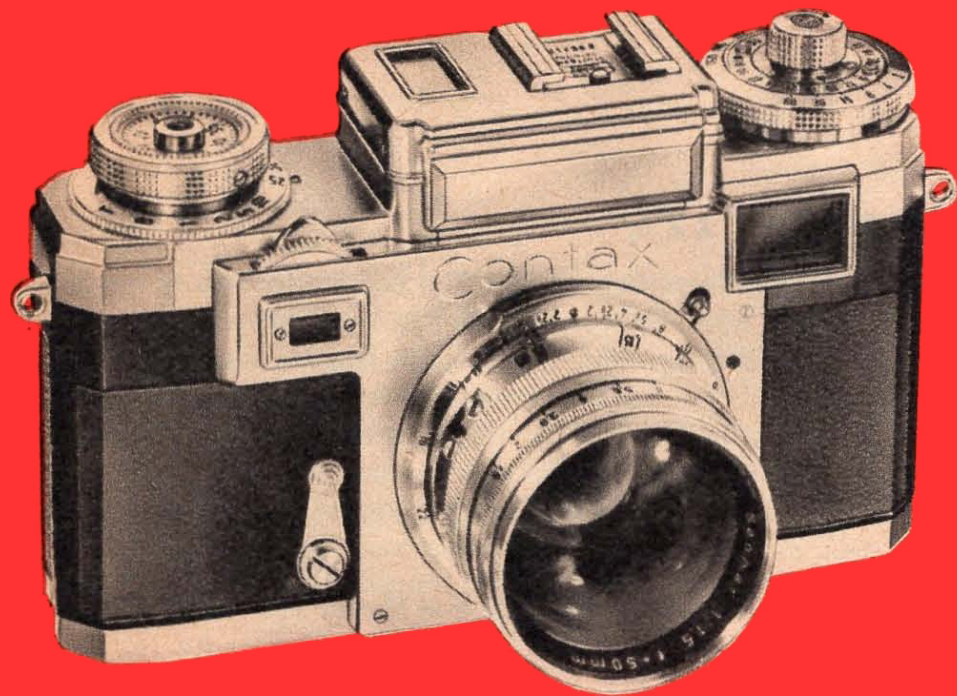

Contax III a with exposure meter

Panflex, Bellows focusing device and Panflex-Tessar with spring-loaded pre-selector iris diaphragm



The interchangeable Zeiss lenses

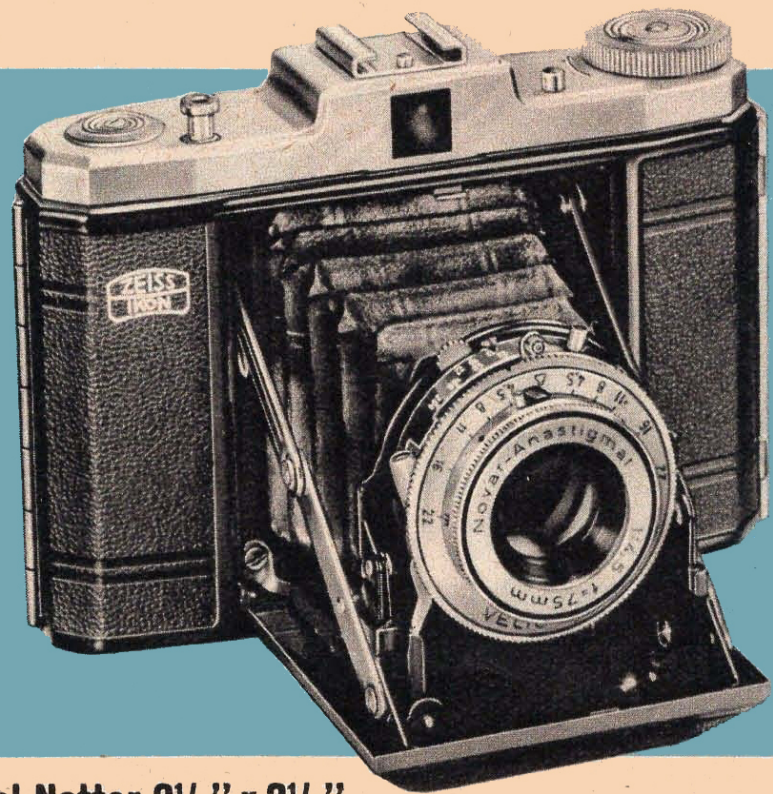

Signal Nettar 2 1/4" x 2 1/4"

Signal Nettar 2 1/4" x 2 1/4"

Moderate price – yet Zeiss Ikon quality! The special feature of the Signal Nettar is the "stop" light. To warn you not to snap off two exposures on one negative a red disc appears in the finder. This means: stop, first wind the film. Then there is the double-exposure prevention lock, self-erecting front – just press a button, the front opens and the lens springs into taking position; when closed all delicate parts are well protected – flash contacts, colour-corrected Novar lens, and Pronto and Prontor Shutters have a delayed action release.

Signal Nettar 2 1/4" x 2 1/4"	Order No.	Signal Nettar 2 1/4" x 3 1/4"	Order No.
Novar f/4.5, Velio	518/16 lh	Novar f/4.5, Prontor-SV	518/2 lpms
Novar f/4.5, Pronto	518/16 lts	Nettar 2 1/4" x 2 1/4" (without lock)	
Novar f/4.5, Prontor-SVS	518/16 lpms	Novar f/4.5, Vario	517/16 lv

Nettax 2 1/4" x 2 1/4"

Of course you would like to take colour pictures too. That is particularly easy with the Nettax, for it has a Rapid photo-electric exposure meter. It gives you an instant reading, and every picture is a winner. As you know, Zeiss Ikon exposure meters are particularly reliable. In addition the Nettax has the same "stop" signal in the finder as the Signal Nettar, and the double-exposure lock, so it is economical in film stock. And the 2 1/4 inch square format makes contact prints large enough for your album. Other features are flash contacts, delayed action release, wide-aperture Novar anastigmat and self-erecting mechanism. Just the right camera for holidays and week-ends.

Nettax 2 1/4" x 2 1/4": Novar f/4.5 Pronto Shutter
Order No. 513/16 Its

ZEISS
IKON

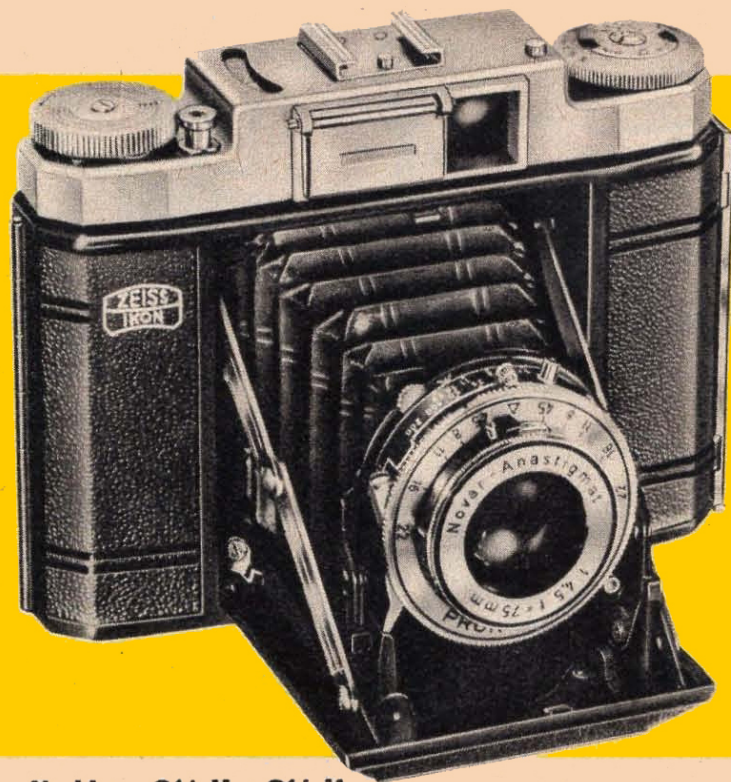

Nettax 2 1/4" x 2 1/4" with exposure meter

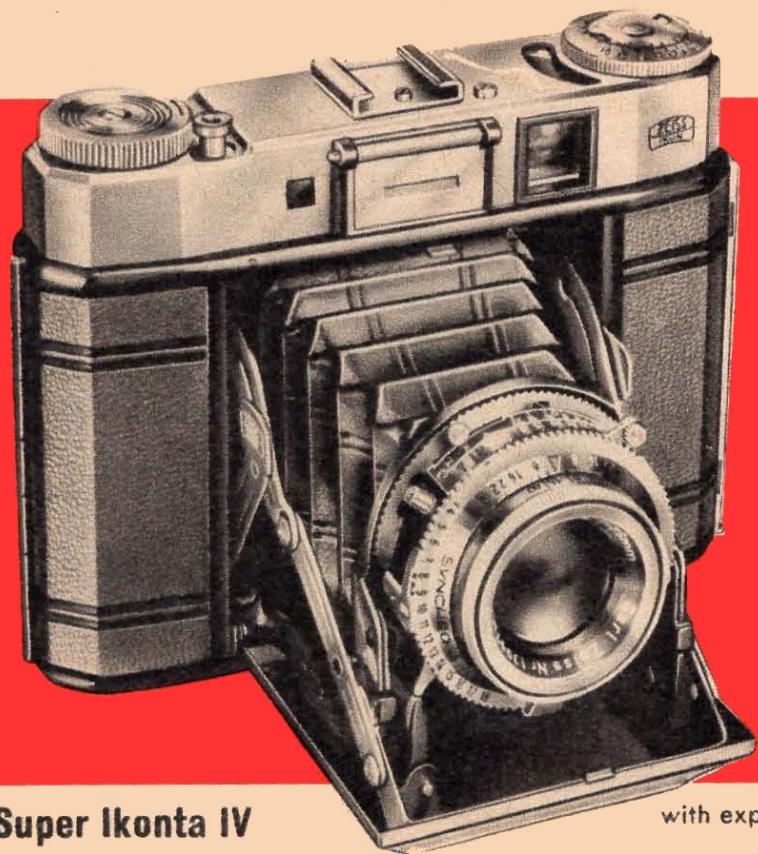

Super Ikonta IV

with exposure meter

Super Ikonta III and IV 2 1/4" x 2 1/4"

With this roll-film camera you simply cannot go wrong. It does your thinking for you, and its refinements are worth years of practical experience in photography. No guesswork is needed in setting the controls. The coupled rangefinder is combined with the viewfinder. On Model IV the Rapid exposure meter also gives an accurate exposure-value reading. So a complete outfit is incorporated in the camera itself. Other Super Ikonta features are delayed action release, XM-flash synchronization, self-erecting mechanism and wide-aperture lenses. The film transport mechanism requires no window. Just wind on until a stop is reached, that is all. Double exposures are impossible too!

IV: Tessar f/3.5, Synchro-Compur
III (w/o meter): Novar f/3.5, Prontor-SVS

Order No.
534/16 Lcms
531/16 Fpms





Ikophot Rapid

Don't guess it – measure it! This advice applies particularly to exposure, for if you set the controls wrong, you will spoil the picture. If you have no built-in meter, then the Ikophot-Rapid is an invaluable aid, especially for colour shots. It gives an immediate reading of aperture, shutter speed or exposure value in any lighting conditions. Its tasteful shape makes it a handsome adjunct to any photographic outfit.

Ikophot Rapid with leather case and chain. Order No. 1329. Special model for cine work: Cine Ikophot.

folding Ikoblitz

As small as a packet of cigarettes – the reflector folds away. This capacitor flashgun has many refinements: test lamp, ejector, fits any camera. No. 1318, Case No. 730.

Ikoblitz 0

with removable reflector and case Order No. 1316.

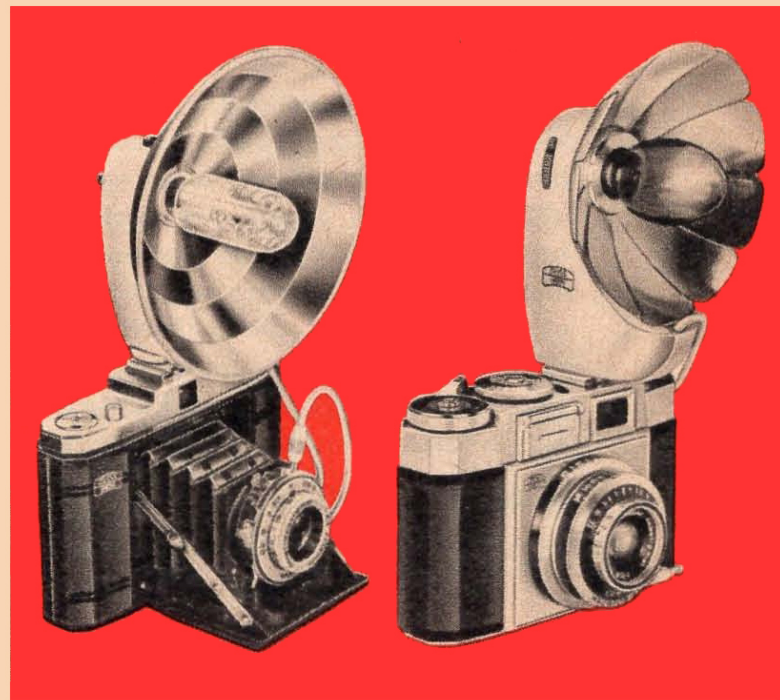

Ikoblitz 0

folding Ikoblitz

Ikoflex Ib and Ic 2 1/4" x 2 1/4"

With the Ikoflex you really have two cameras: one to take the picture, the other as a "subject-finder." When the focusing hood springs open, you see the picture as it will look when you paste it in your album: in natural size and brilliantly clear. Zeiss Ikon is particularly proud of the focusing screen. The picture is bright right into the corners, and you can check the focusing all the time. While you do so the taking lens is automatically set on the correct distance. A hinged magnifier ensures maximum accuracy. On the Ikoflex Ic you also see the exposure meter needle in the finder – which is very handy in changeable lighting conditions. Simple manipulation is assured by a film transport mechanism incorporating a positive stop. There is a lock to prevent double exposures and blanks. The Prontor shutter has a delayed action release and XM-synchronization and is speeded to 1/300 sec.

Ikoflex Ic: with Novar f/3.5 Order No. 886/16 Fpms
with Tessar f/3.5 Order No. 886/16 Lpms

Ikoflex Ib (without exposure meter):
with Novar f/3.5 Order No. 856/16 Fpms.

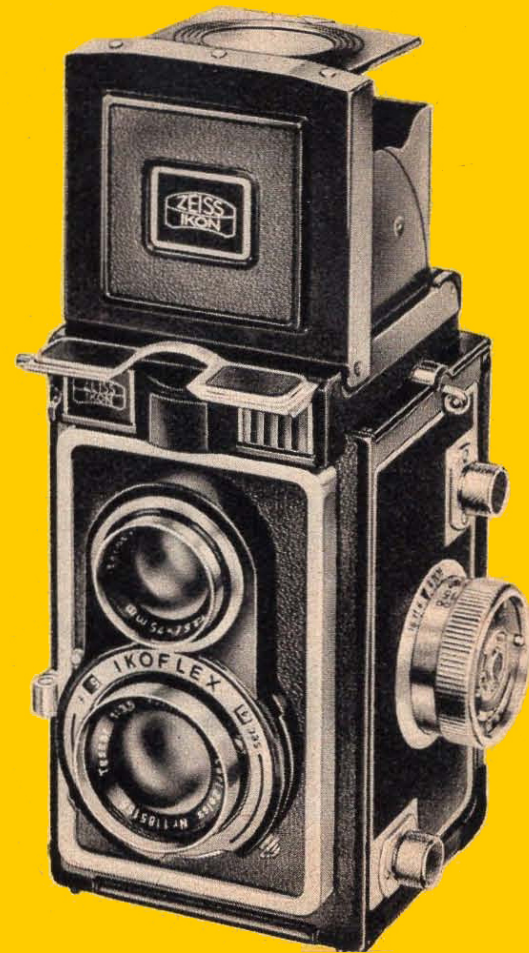

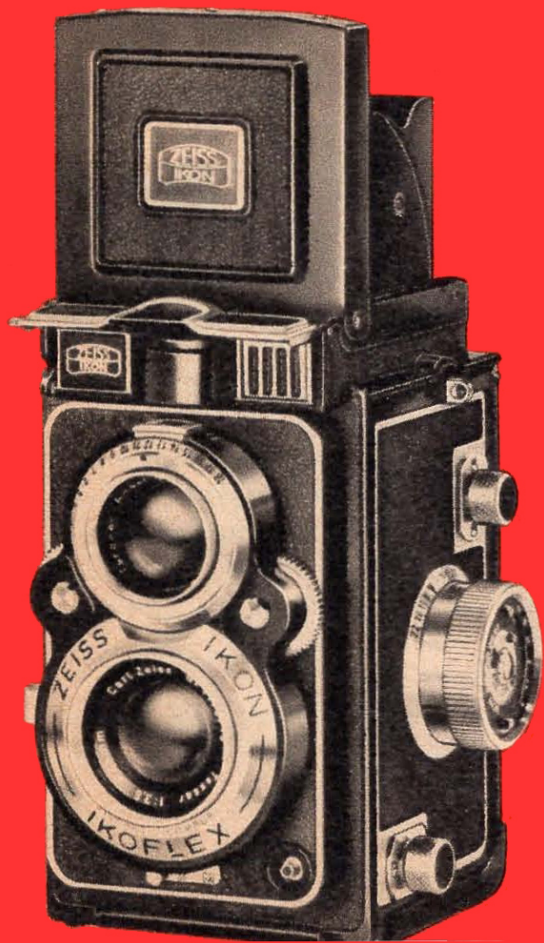

Ikonoflex Favorit 2 1/4" x 2 1/4"

Experienced photographers know the reason why they get their best pictures with a twin-lens reflex camera. The Ikonoflex Favorit gives you a head start on every other camera. It incorporates all features of the model Ic, and the following besides: film transport is coupled to shutter winding; the window is dispensed with even for loading. So you can easily reload in the dark. The XM-synchronized Compur shutter has an exposure-value scale and speeds up to 1/500 sec. The controls incorporate locking devices to prevent mistakes, and all settings can be read off from above. The picture area, focus, and – thanks to the built-in exposure meter – the light are all observed in the finder. The optical equipment is of special importance to the colour worker: a Zeiss Tessar with a maximum aperture of f/3.5, already proved in thousands of cameras throughout the world.

Ikonoflex Favorit: Tessar f/3.5, Synchro-Compur, Order No. 887/16 Lcms
Accessories for close-ups (Ikoprox) etc., available for all Ikonoflex models.

Zeiss Ikon
Cable Release



Zeiss-Ikon accessories for all Zeiss Ikon cameras and lenses

Zeiss Ikon precision filters get the best out of your pictures: clouds, contrasts, clear rendering of distant subjects. They are prepared under strict optical supervision and are available in seven types, mostly coated.

Polarizing filters: Contapol or Bernotar, eliminate unwanted reflections. With colour film they also serve to enhance cloud effects.

Lens hood protects the lens from stray light, and in bad weather from rain and snow. Your pictures have more sparkle.

Zeiss Proxar lenses for close-ups down to 20 and 12 inches, and with Contaflex and Contina down to 6 $\frac{1}{4}$ inches.

Zeiss Ikon cable release for rock-steady exposures with a tripod. It has a lock for time exposures.

Ever-ready case: keeps your valuable Zeiss Ikon camera safe even while you are taking the picture, and the camera is always ready for use. Handy leather cases are available for the accessories.



Zeiss Ikon
Precision Filters



Zeiss Ikon
Lens Hood

Ikolux Projector for 2" x 2" slides

Would you think of stopping half way in your profession, and giving up the achievement of your ambition? Of course not! So in photography why be satisfied with paper prints? To get the full effect you make slides and have them projected. But you need the brilliant illumination provided by the Ikolux. For home use the moderately-priced model 150, for larger audiences the 300 with fan cooling, adaptable to any size of room by use of interchangeable lenses. The rapid slide changer is a useful extra accessory. For Stereo accessories see p. 9. Your dealer can supply a full prospectus.

Ikolux 150: with Globar f/2.5 - 85 mm	Order No.1482/1	Slide changer with
Ikolux 300: with Globar f/2.5 - 85 mm	Order No.1483/1	magazine No.1478/027.
with Orikar f/2.5 - 100 mm	Order No.1483/2	Magazine only
with Orikar f/3.2 - 150 mm	Order No.1483/3	No. 1478/029.

Ikolux S 300 with economy switch and Ikolux 500 for 2" x 2" and 2³/₄" x 2³/₄" slides – particulars on application.



Ikolux 300

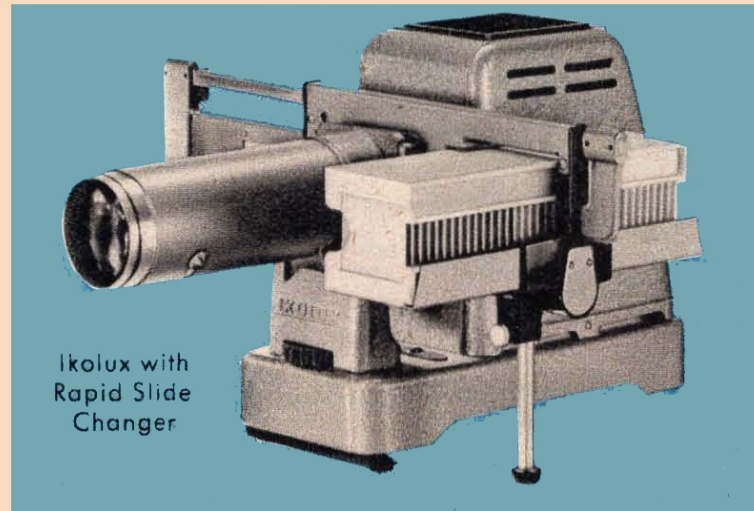

Ikolux with
Rapid Slide
Changer

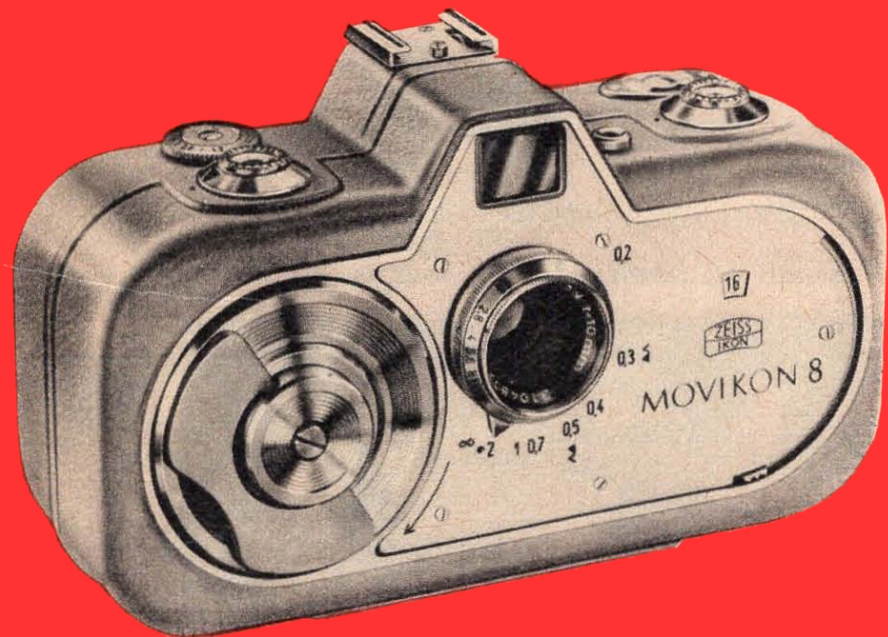

Movikon 8 "transverse"

Do you like going to the movies, or do you prefer to look at picture-books? Of course a film is more life-like, so why not store your own happy memories in a film? Take up movie-making. Once you make a start, you will never get away from this fascinating hobby. The horizontal Movikon 8 and its system offer you unlimited scope.

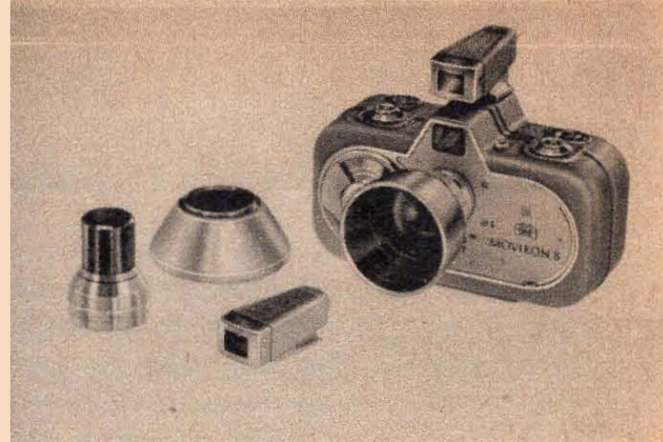

Movikon 8 with telephoto and wide-angle attachments

Movitrix titler with Movilum

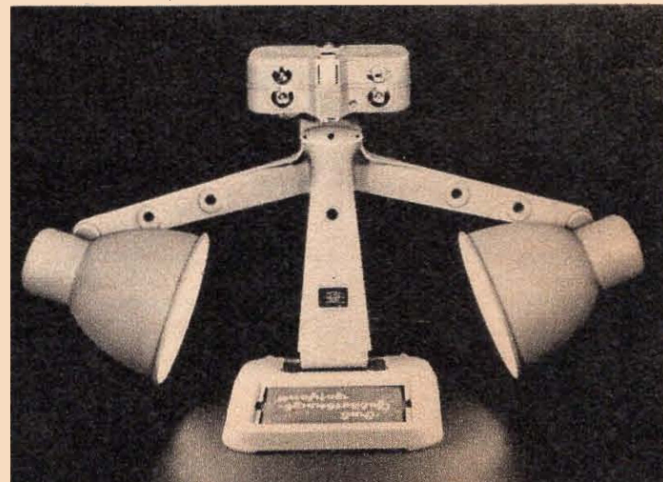

Movikon 8 "transverse"

The famous cine camera with transverse design. What does that mean? The horizontal shape guarantees that the camera lies comfortably in your two hands, enabling you to devote all your attention to directing and shooting the film. This makes filming really easy. The Movikon 8 is very versatile: easy to load thanks to the removable back, four running speeds (16, 24, 32 and 48 pictures per second). Single-frame exposures, continuous running lock. The wide aperture f/1.9 Movitar lens can be focused for close-ups down to 8 inches without supplementary lenses. The lens attachments enable you to introduce plenty of variety by including wide-angle and telephoto shots. Then there is the universal yet moderately-priced Movitrix for titles and special effects, with which you can make a complete film studio of your own. For title illumination and especially for interior shots, there is the Movilum. And to prepare your films for projection there is the Moviscop. **Movikon 8** with Movitar f/1.9 - 10 mm – Order No. 5532/288.

The Movikon System: Movigonar (wide-angle) order No. 5532/07, Movitelar (telephoto) order No. 5532/06, Cine Ikkophot exposure meter, order No. 1329, Movitrix titler, order No. 1426, Movilum lighting unit, order No. 1310, Moviscop editor, order No. 1431/28 (also available for 16 mm, order No. 1431/30). For details of projector and sound equipment see the following pages.

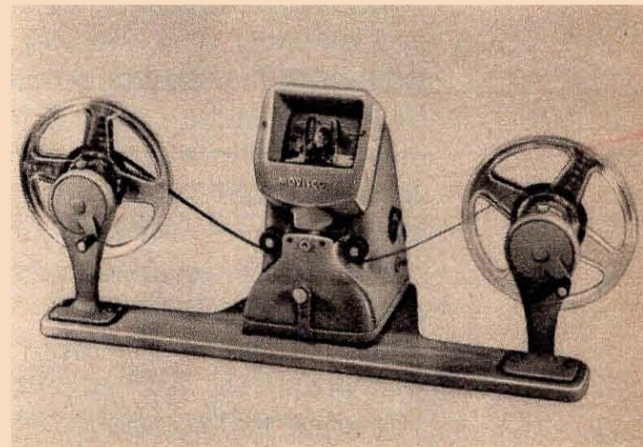

Moviscop editor



Movilux 8

When you buy a projector, think of the future. The Movilux 8 is equipped for future developments. First and foremost it is one unit of Zeiss Ikon equipment with which you can easily add sound to your films. With its 300 watt lamp and wide-aperture lens the Movilux gives a brilliant screen image. Its motor (induction type) runs silently and at constant speed, a most important requirement for sound reproduction. Absolute picture steadiness, bearings permanently grease packed and requiring no maintenance, and easy threading are additional features. Handy suitcase shape; all parts well protected. You can easily take the Movilux with you when visiting friends.

Movilux 8 Order No. 1491. Synchronizing switch for any tape recorder Order No. 1491/01.

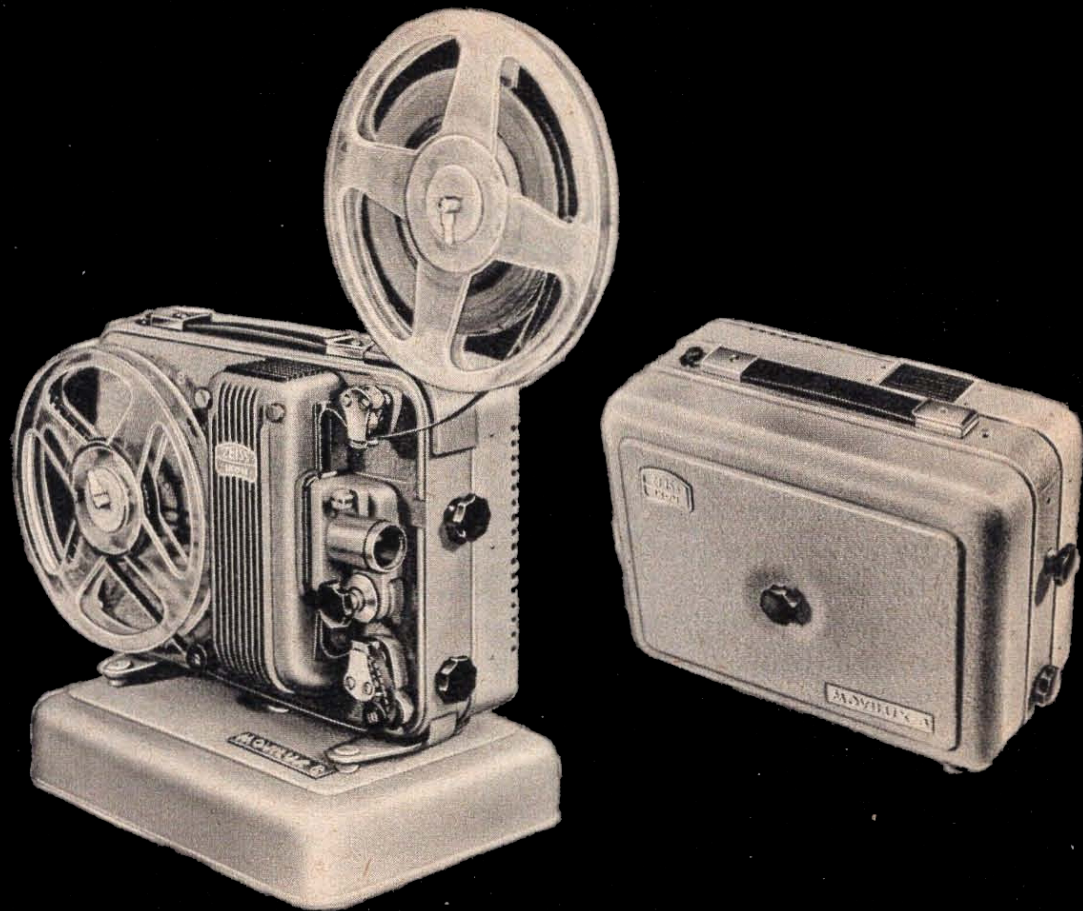

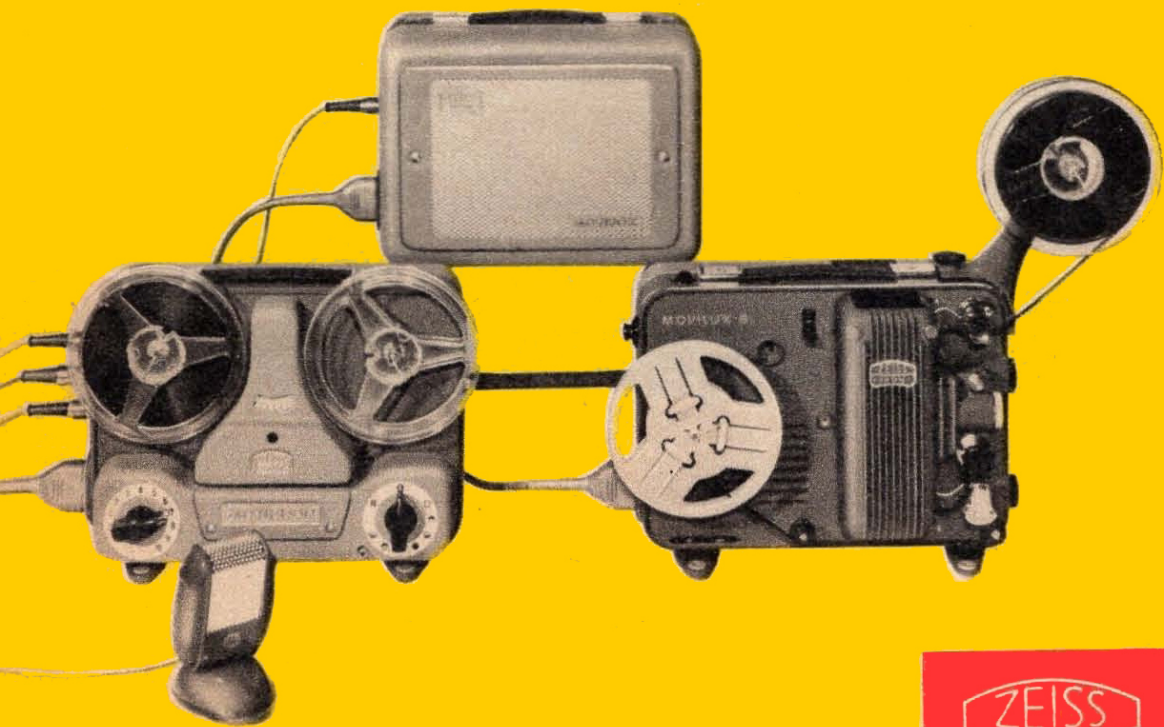

ZEISS
IKON

Moviphon

Together with the Movilux 8 this forms a complete 8 mm. sound projection outfit which is easy to operate and versatile in scope.

Novel features are the drive of the tape recorder unit, the Moviphon, by the Movilux motor via a flexible shaft without further accessories. This provides frame synchronization of the film and tape. Two parallel tracks, which can be played back separately or together, simplify adding sound to the film. The amplifier incorporates transistors which, unlike radio valves, do not wear out. The Movivox loud speaker with built-in amplifier (see illustration above) is only required if you have no radio set. Delivery from second semester 1957.

Moviphon, Order No. 1495; moving coil microphone, order No. 1495/02; Movivox, Order No. 1495/01.



ZEISS
IKON



Order No. : 2026 englisch 2 Printed in Germany, Author: J. Kraatz 0457

Z E I S S I K O N A G . S T U T T G A R T