

**The new Kodak Retina and
its System**

In all technical fields

genuine progress must be based on a sound foundation of existing achievement. In the 20 years since its inception the RETINA has developed into a leading camera of its class and has thoroughly proved its robustness, reliability, and versatility all over the world. But technical development never stands still. Out of the sum of many years' development grows new knowledge which finds practical application in new designs. Thus the new RETINA has been perfected into a miniature camera with new pioneering features, increased versatility, and many proven advantages.

The new RETINA Ib literally "has got something". New constructional ideas have been applied which make photography with this miniature camera supremely simple even in unusual conditions. The collapsible lens panel, locking absolutely rigid for perfect lens alignment, the new line frame viewfinder with its bright, reflected outline of the picture area and its parallax indicator, the new Synchro-Compur shutter with light value settings and built-in self-timer, the high-quality 2 inch (50 mm) RETINA Xenar f/2.8 lens: all these features, together with the stylish yet handy body, give the RETINA Ib its own particular character: a versatile and up-to-date camera for exacting amateurs.

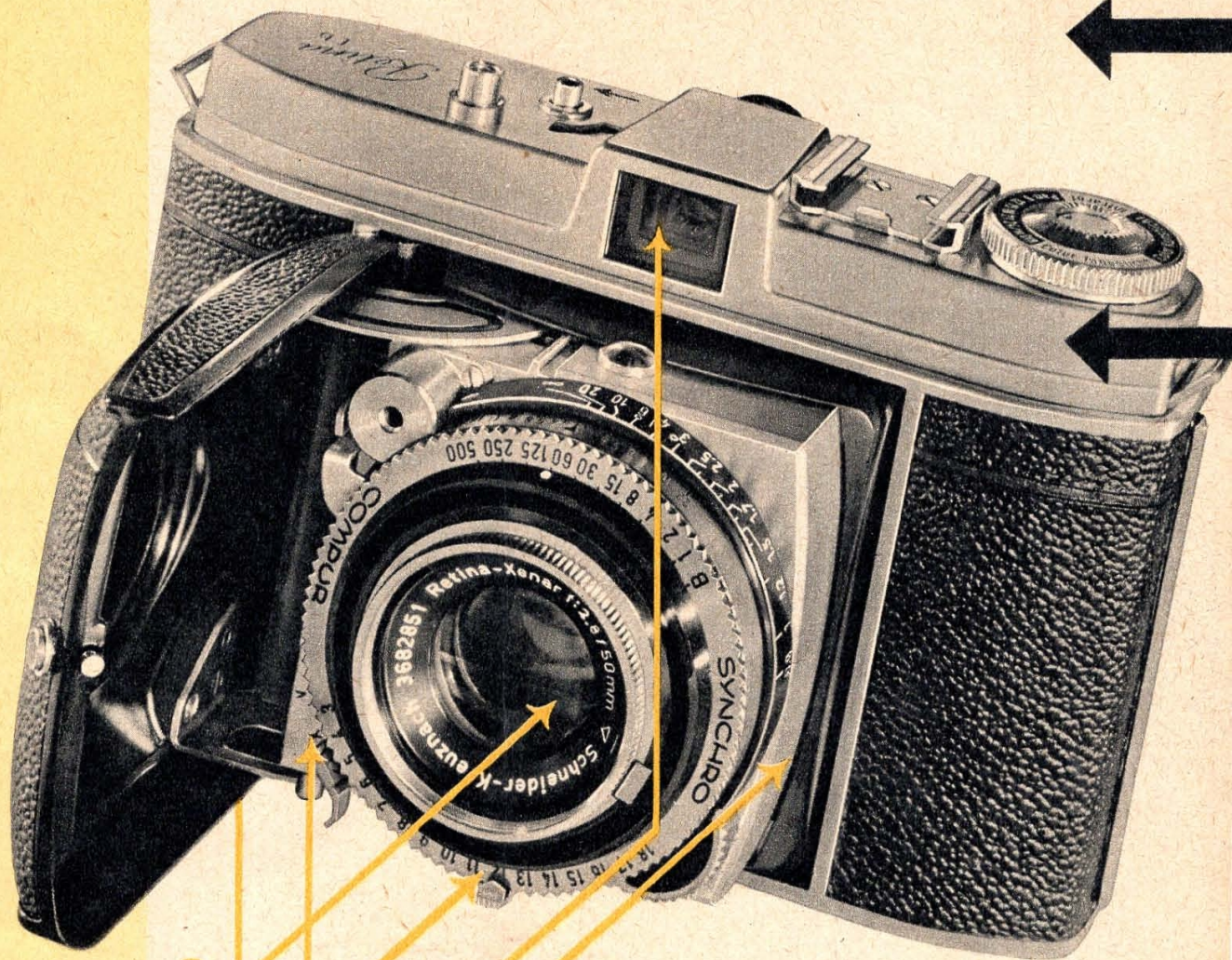

2 inch (50 mm) RETINA-Xenar f/2.8,
Synchro-Compur shutter with
built-in self-timer and
light value settings,
Rapid winding lever,
Collapsible lens panel, locking
absolutely rigid,
Stylish, elegant body.

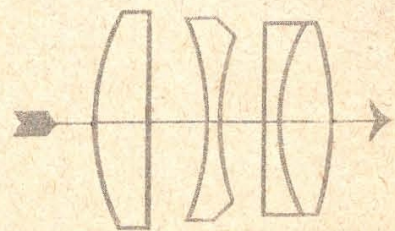

When reading this page please
open out the folded-in page 10.

Kodak
Retina

16

RAPID WINDING LEVER

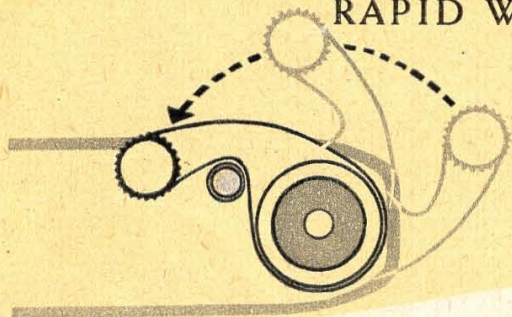

Real live action shots don't just happen. You have to be quick if you want to capture the fleeting moment or take several sequence shots in rapid succession. The RETINA is just what you need. Sighting, releasing the shutter, re-winding the film: all this takes longer to read than to do. The RETINA never lets you down - it is always ready for action.

THE SPEED-SYNCHRONIZED SHUTTER

Quick as a flash - bright as a flash. True enough, for the RETINA with its speed synchronized shutter knows no lighting problems. Flash bulbs and electronic flash can be used at all speeds, including the shortest shutter speed of $1/500$ second. The RETINA with its speed-synchronized shutter can deal with any situation.

HANDY ELEGANT BODY

A fine camera gives pleasure to the eye as well. The RETINA has no awkward corners or sharp edges. Stylishly rounded, it really nestles in your hands. The shapely and functional body even helps with your pictures because you can hold the camera securely and operate it smoothly. With the baseboard closed, you can carry it in comfort.



RIGID, YET COLLAPSIBLE LENS PANEL

The absolutely rigid locking of the lens panel guarantees that the high quality of the RETINA lenses is not wasted. The panel is supported by the camera body, not by the baseboard. The latter only serves to slide the panel out until it locks. The lens panel is easily unlocked; on closing the baseboard it glides smoothly back into the camera body. Locking rigid and yet collapsible, that means: whenever the camera is open for picture taking the lens is accurately positioned; whenever the camera is closed, the lens is safely protected against all outside hazards like knocks or pressure, as in a safe-deposit box. Focusing is effected by moving the lens bodily, not by adjusting its front element.

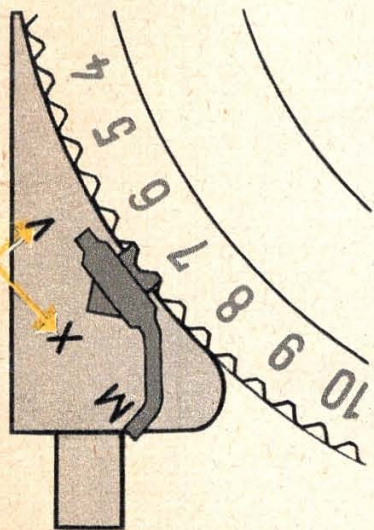
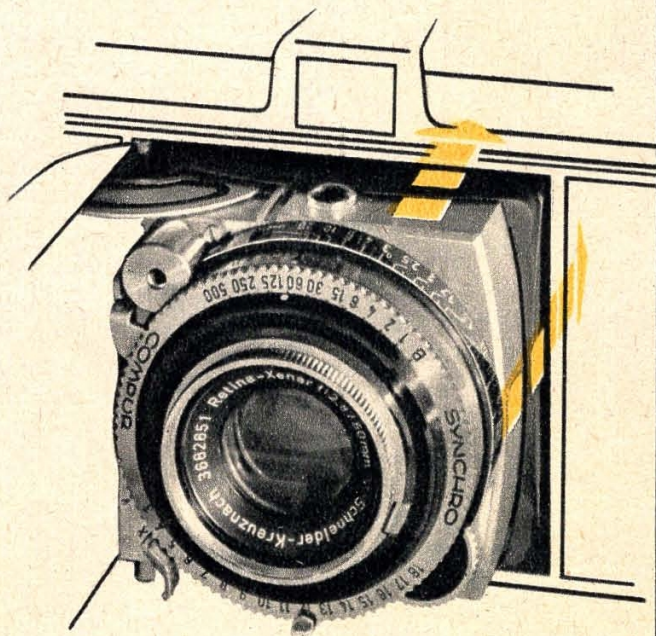

BUILT-IN SELF-TIMER

There was always one missing from the family picture in the album: the photographer. The self-timer built into the Synchro-Compur of the new RETINA gets the whole of the family in the picture. And when you are alone you can take self-portraits without any trouble.



And now: The RETINA has interchangeable lenses.

A wish long harboured by many miniature enthusiasts has been fulfilled in the

RETINA II c and III c. Better still:

The RETINA provides the ideal solution to the problem of fitting interchangeable lenses without having to sacrifice the between-lens-shutter (Synchro-Compur). In order to ensure uniform illumination of the negative at all shutter speeds and aperture settings, we refrained from putting the shutter behind the lens and instead kept it between the elements of the lens. Thus it remains at the optically correct place with all focal lengths: at the point of intersection of the light rays. The standard 6-element 2 inch (50 mm) f/2.8 RETINA-Xenon C and RETINA-Heligon C lenses as well as the interchangeable lenses have been specially computed for the RETINA II c. They show outstandingly brilliant definition and, because of their colour correction and specially adapted coating, are eminently suitable for colour photography.

In the new RETINA II c, the viewfinder and rangefinder have been combined into one unit, using the same eyepiece. The rangefinder is coupled with the lens and focusing takes but a moment.

INTERCHANGEABLE LENSES

Synchro-Compur shutter with light value settings, coupled shutter speed and aperture settings, and built-in self-timer.

Collapsible lens panel, locking absolutely rigid.

Stylish, elegant body.



 Six-element 2 inch (50 mm) f/2.8 RETINA-Xenon C or RETINA-Heligon C lens. Coating specially adapted for colour film.

 Built-in coupled rangefinder combined with bright line frame viewfinder.

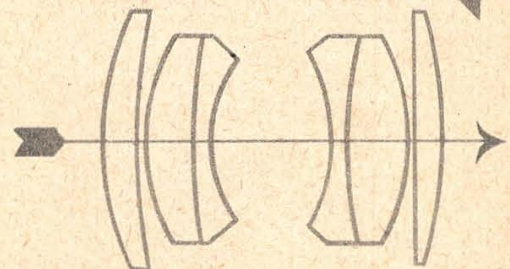

When reading this page please open out the folded-in page 10.

 Kodak
Retina

IIc



You will find all the advantages of the RETINA II c in the RETINA III c as well. In addition, the RETINA III c uses the fast 2 inch (50 mm) f/2 lenses and has a built-in photo-electric exposure meter.

In two different but equally simple and quick ways the light value is found, either by pointing the meter towards the subject (reflected light method), or the other way round, from the subject towards the taking position (incident light method). With the new Synchro-Compur shutter you can set the correct exposure more quickly and simply because there is only one setting, the light value, Shutter speed and aperture settings are coupled together.

Altering the shutter speed setting automatically adjusts the aperture to the equivalent setting as long as the light value remains the same. On the other hand, resetting the aperture automatically alters the shutter speed. Therefore, the amount of light reaching the film (i. e. the exposure) remains constant. Of course, both shutter speed and aperture can still be set in the hitherto usual manner.

INTERCHANGEABLE LENSES

Synchro-Compur shutter with light value settings and built-in self-timer

Solid collapsible lens panel locking absolutely rigid

Bright line frame viewfinder

Coupled rangefinder

Stylish, elegant body

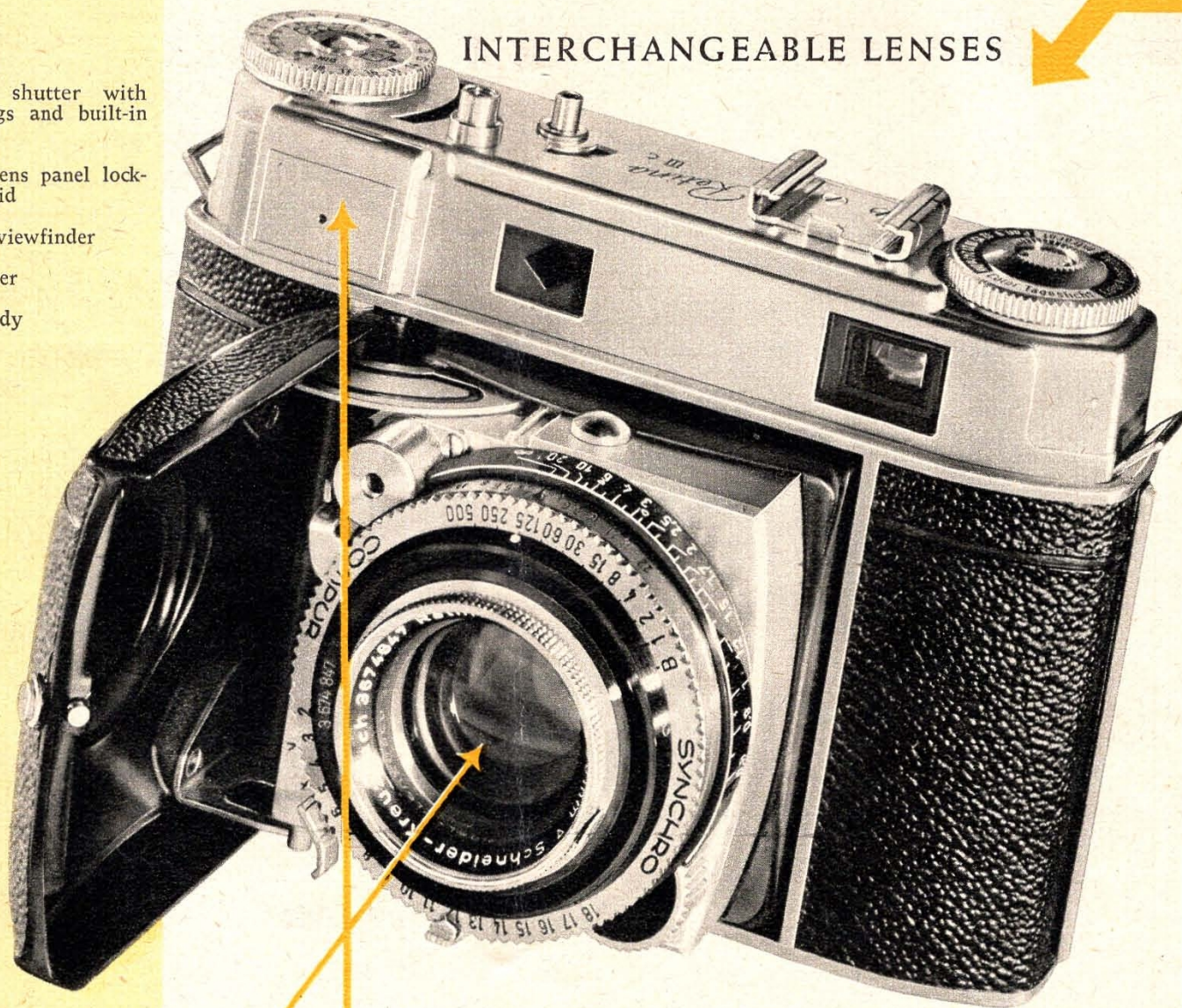

+

Six-element 2 inch (50 mm) f/2 RETINA-Xenon C or RETINA-Heligon C lens. Coating specially adapted for colour film

Built-in photo-electric exposure meter for reflected light and incident light reading

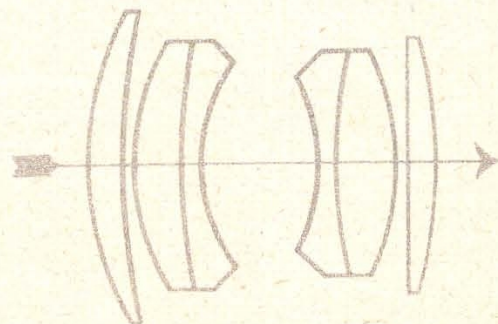

Kodak
Retina

III c



The Line Frame Viewfinder

has a bright, large field of view. A reflected line frame with parallax indicator marks shows you the exact picture area. Spectacle wearers are also able to see the whole field of view. If you have faulty vision but do not wear spectacles, you can screw a correction lens into the eyepiece mount.

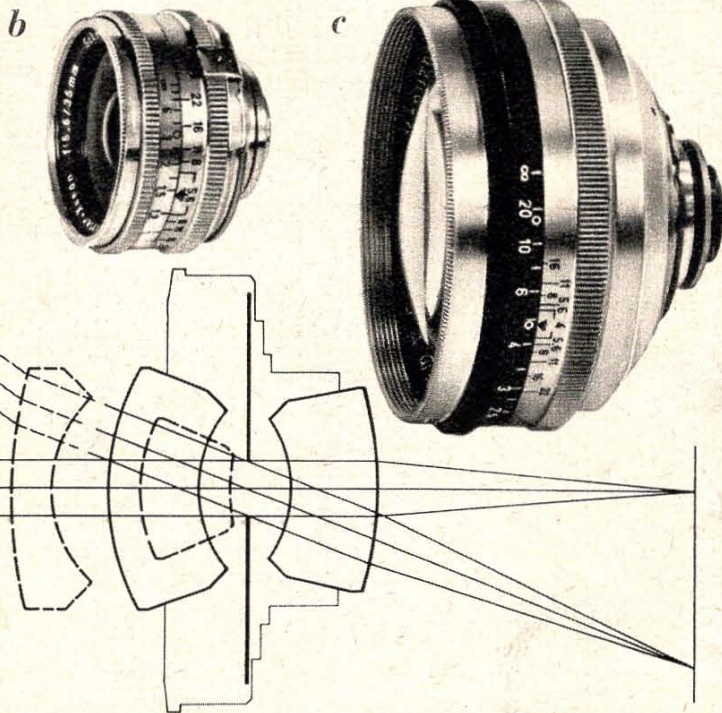
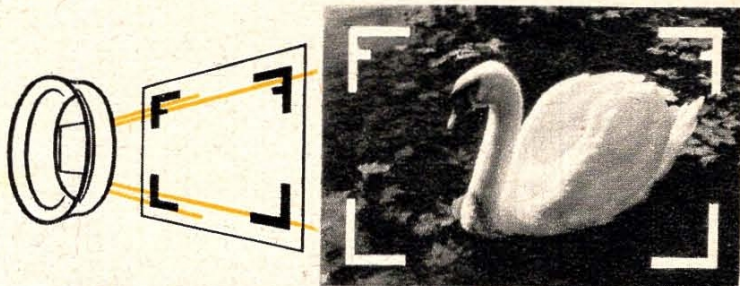

Interchangeable Lenses

Three focal lengths are available for the RETINA II c and III c:

- Standard lenses: 2 inch (50 mm) f/2 RETINA-Xenon C or RETINA-Heligon C (f/2.8 for the RETINA II c).
- Wide-angle lenses: 1³/₈ inch (35 mm) f/5.6 RETINA-Curtar-Xenon C or RETINA-Heligon C.
- Telephoto lenses: 3¹/₈ inch (80 mm) f/4 RETINA-Longar-Xenon C or RETINA-Heligon C.

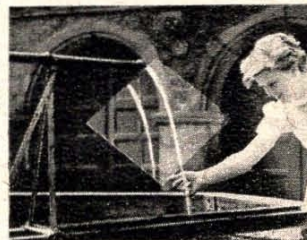

The Coupled Rangefinder

The diamond shaped rangefinder field within the field of view first shows the subject with double outlines. All you have to do is to turn the focusing knob of the distance scale until the outlines fuse into one. The camera is now correctly focused.

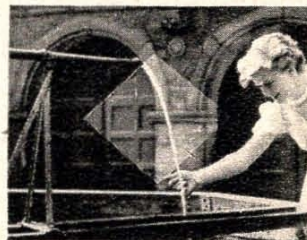

Built-In Photo-Electric Exposure Meter

The built-in, shockproof, exposure meter of the RETINA III c indicates the correct light value for any lighting conditions, whether subdued light indoors or in brilliant sunlight outdoors. Its two light scales cover an unusually wide measuring range. If the subject is bright, sufficient light penetrates through the small aperture in the closed cover of the meter; in dull light the cover is opened. The exposure meter is suitable for incident light readings as well as reflected light readings. For incident light readings, a diffusing screen is fitted over the front of the meter (see cut a).

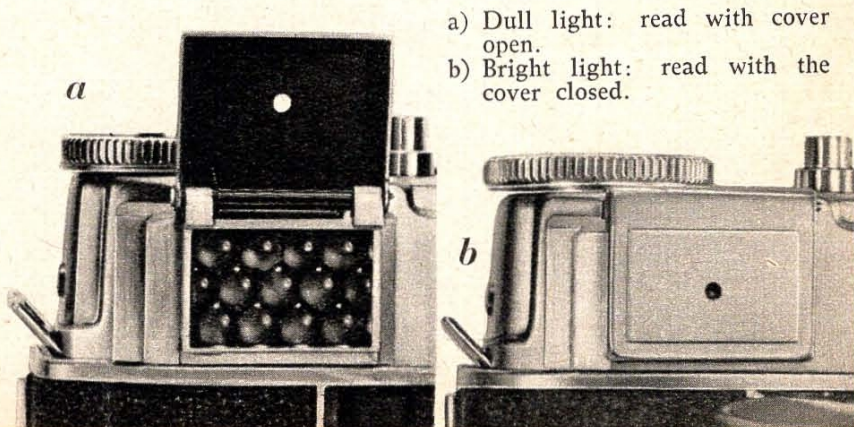

- Dull light: read with cover open.
- Bright light: read with the cover closed.

Shutter Speed Index Mark

Shutter Speeds

The Shutter of the RETINA Ib - IIc - IIIc

is the Synchro-Compur shutter with light values, coupled shutter speed and aperture settings, and built-in self-timer. The new shutter greatly simplifies the manipulation of the camera. Only one value, the light value, has to be set and this gives the correct exposure automatically, for the light value includes both shutter speed and aperture. In the illustration (right) the light value 12 has been set. It corresponds, for instance, to a shutter speed of $1/60$ second at $f/8$. If you now wish to use the faster shutter speed of $1/250$ second, you simply set the shutter to $1/250$. This automatically opens the aperture to $f/4$. Therefore, the exposure given by the light value setting remains always constant. If you change the aperture setting from, say, $f/8$ to $f/22$ (if you want greater depth of field which can be read off the depth of field scale for any distance and aperture) the shutter speed automatically changes from $1/60$ second to $1/8$ second. Your exposure is always right.

These simpler settings are the result of the coupled speeds and apertures and of the new uniformly spaced shutter speed and aperture scales. The light value system makes the RETINA still quicker in action.

Light Value Scale

Speed Synchronization and Self-Timer

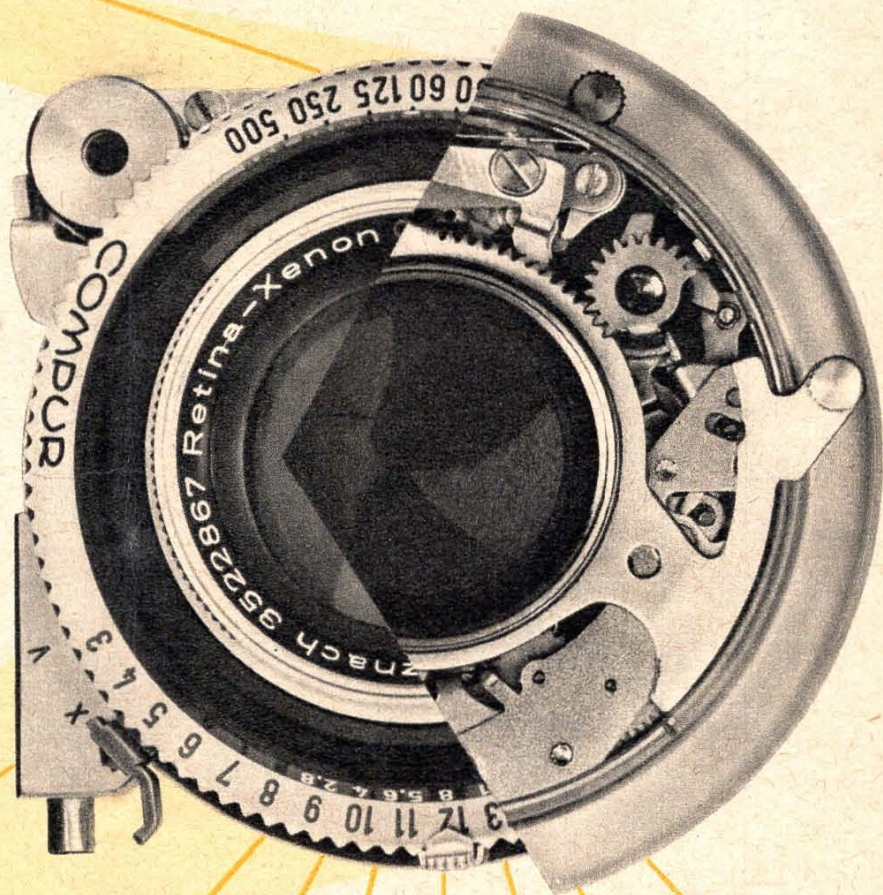

2,8

4,0

5,6

8,0

11,0

16,0

22,0

TELEPHOTO AND WIDE-ANGLE LENSES with Between-Lens Shutter

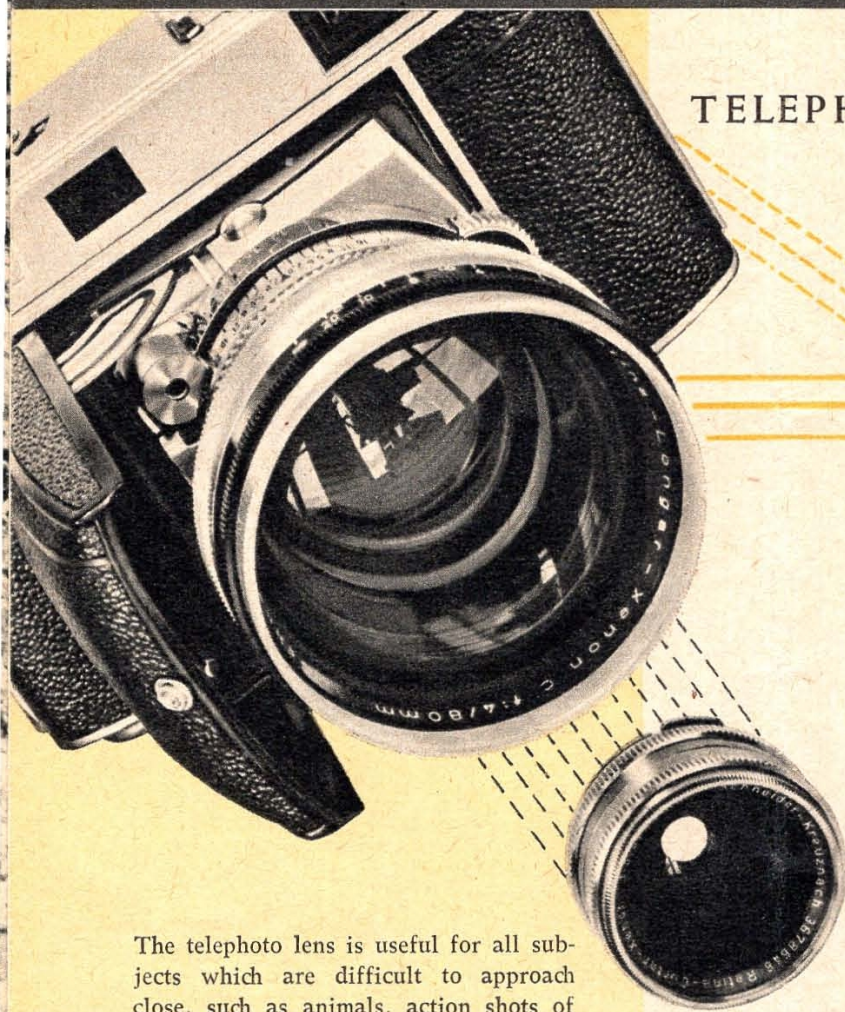

Diagram of the RETINA lens system: With all focal lengths, the shutter remains between the elements at the only correct place: the point of intersection of the light rays. This guarantees uniform illumination of the negative at all shutter speeds and apertures. The dotted lines show the RETINA wide-angle lens.

The telephoto lens is useful for all subjects which are difficult to approach close, such as animals, action shots of children and sports pictures. It is also very suitable for portraiture. The wide-angle lens does the job when you have to include a large angle of view, as with interior, architectural, and panoramic photographs. Besides, its great depth of field makes it very useful for action shots of larger groups in movement, with or without flash. With both the telephoto and the wide-angle lenses the taking distance it set semi-automatically by means of the rangefinder. The ingenious bayonet lock securely anchors the lenses yet allows their quick interchange.

The Same Taking Position - Two Different Photographs

a taken with
the telephoto lens

b taken with
the wide-angle lens

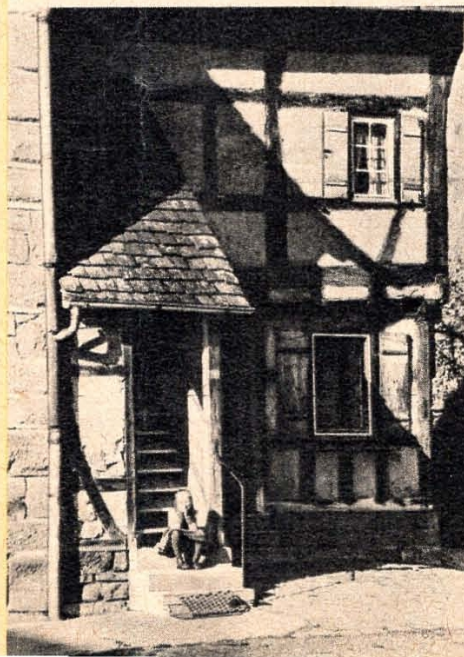

The KODALUX L Photo-Electric Exposure Meter

Lighting conditions change during the day and during the year. You need some experience to guess every time. In particular, you have to expose colour films with their limited exposure latitude correctly, if you want good colour rendering. The KODALUX L, a photo-electric exposure meter of great reliability and wide measuring range, gives readings of the light value as well as the corresponding shutter speed and aperture under any lighting conditions. A diffusing screen is hinged to the front of the cell and can be folded up or down. When folded down, it permits incident light readings for very contrasty subjects. The correct setting can be read off immediately. For reflected light readings (from the camera position to the subject) the diffusing screen folds out of the way. The honeycomb of the meter allows only those rays which come from the direction of the subject, to reach the light-sensitive cell.

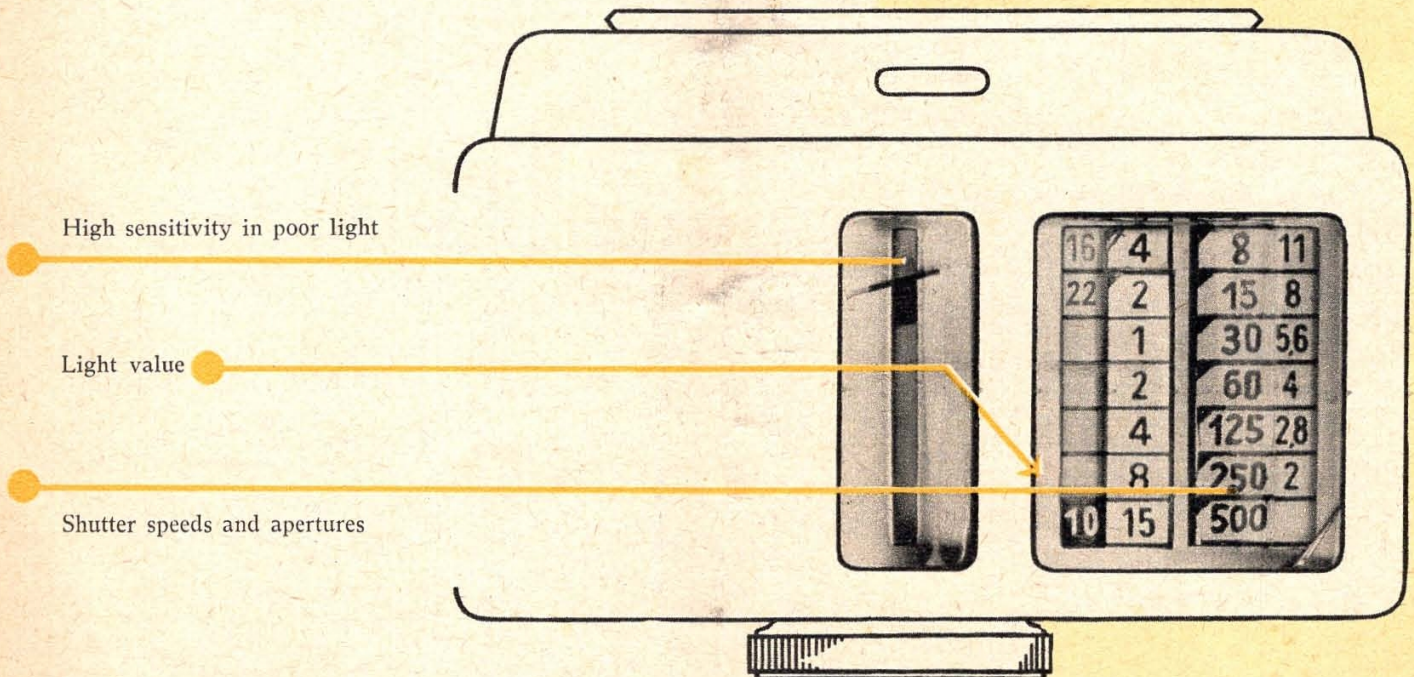
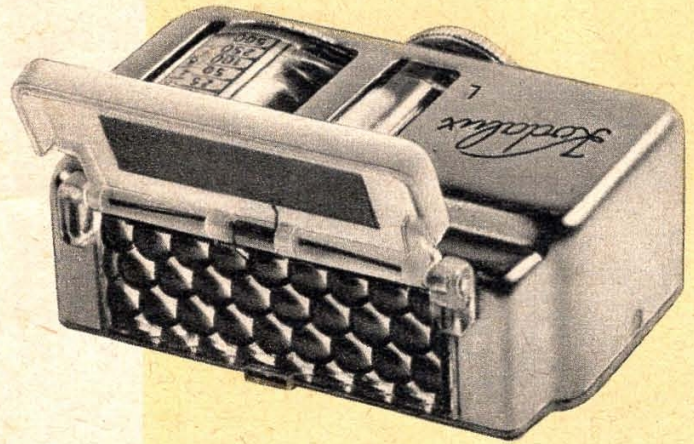

THE RETINA FRAME FINDER AND OPTICAL MULTIPLE FINDER

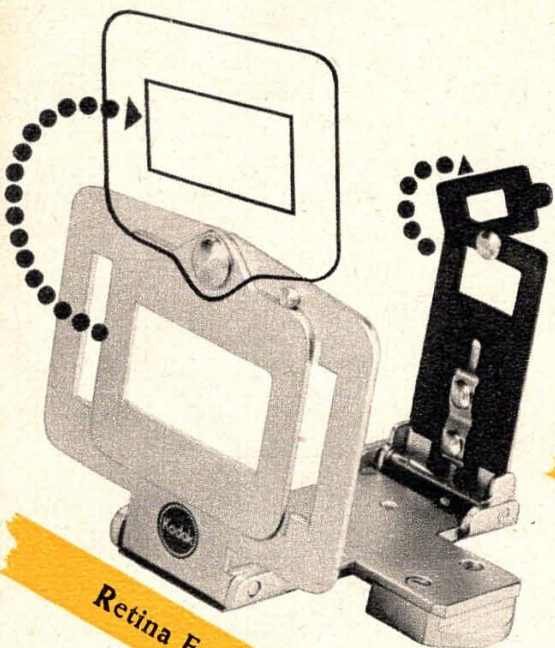

Retina Frame Finder Model c

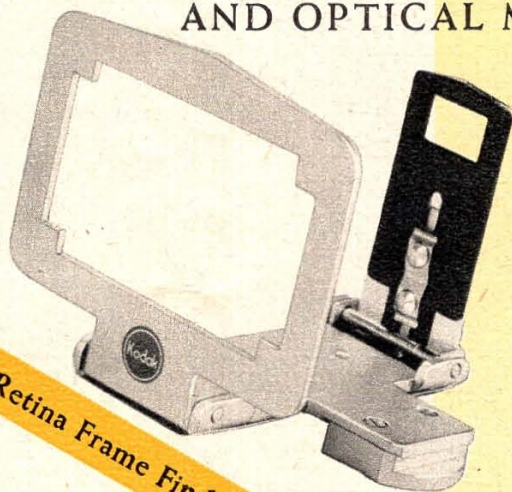

Retina Frame Finder Model b



Optical Multiple Finder



For Telephoto
and Wide-Angle Shots

The *Retina Frame Finder* models b and c have been designed for shooting moving subjects and quick-changing scenes, such as we meet especially with sport pictures. With this frame finder you can sight practically any moving subject in its natural size and positively place it in the picture area. When you press the shutter release you'll know you have caught the right moment.

The *Retina Frame Finder* model b is intended for the RETINA Ib, while owners of the RETINA IIc and IIIc use the Model c finder because this is also suitable with the telephoto lens. For tele shots the smaller frames swing down, for shots with the standard lens they are swung up out of the way. Both

finders have parallax compensation down to a taking distance of 12 inches and can thus be used for close-ups with the supplementary N lenses.

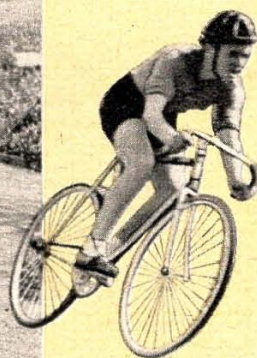

The *Optical Multiple Finder* is ideal when using telephoto and wide-angle lenses. Its bright field of view, instantly adjusted for either the telephoto or the wide-angle lens, shows the exact picture area. Naturally, the *Optical Multiple Finder* also has parallax compensation.

THE KODABLITZ FLASH GUN

RETINA plus KODABLITZ - with this combination you are always ready for action, in any light and at any time. The KODABLITZ flash gun is not only useful at night or in dark interiors, it is also indispensable in bright sunshine for relieving dark shadows, specially when shooting against the light. The design of the grained surface of the reflector, based on the latest advances in light technique, ensures a pleasant, diffused, flood of light. The 22.5 volt dry battery will also power two to three KODABLITZ extension flash holders without the need for additional current. The feet of the main KODABLITZ and of the extension units are threaded for mounting on a tripod. Extension leads of 6 and 10 feet give mobility and make it possible to light up the largest halls. The hot burnt-out bulbs are thrown out by the ejector without having to be touched.

Right:
KODABLITZ
and extension unit.

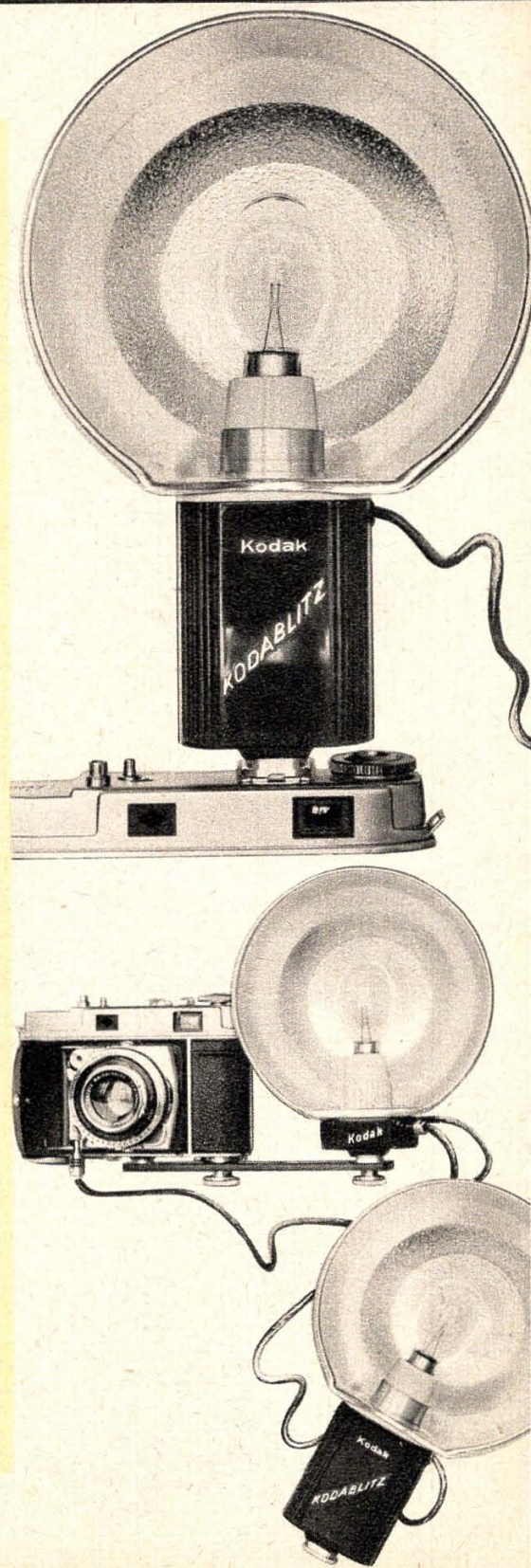

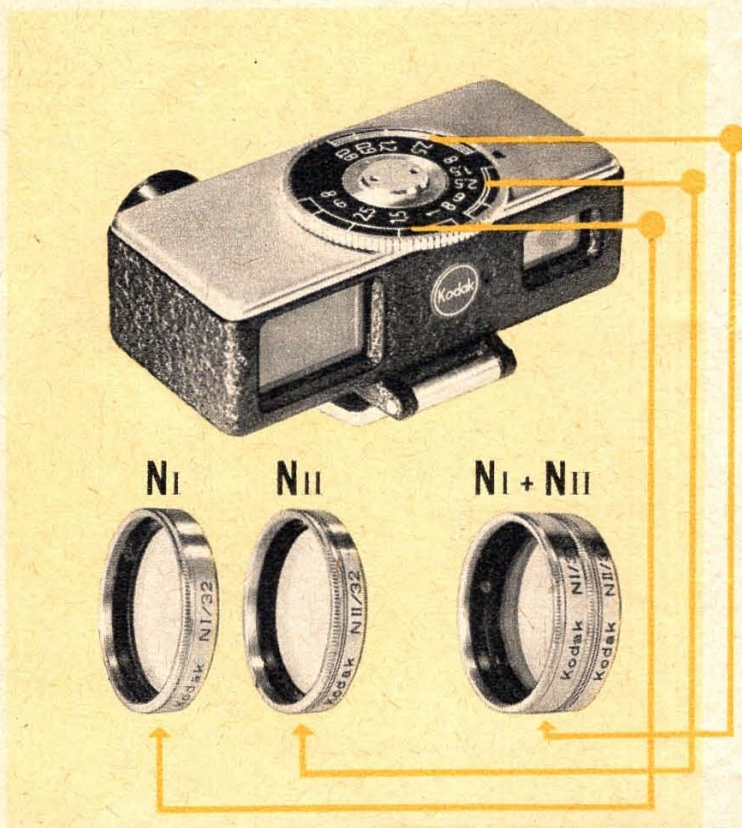

THE RETINA CLOSE-UP RANGEFINDER

The world is large. But a wealth of beauty, of forms and shapes, and of photographic opportunities can be found in the world of little things. With the RETINA *Close-Up Rangefinder* and its two supplementary N-lenses amateurs and professionals alike can tackle the range below the 3 foot limit, i. e. between one and three feet (27 cm to 97 cm). The RETINA *Close-Up Rangefinder* is a combined rangefinder with one eyepiece and automatic parallax compensation. Working with it is child's play: you only have to push the close-up rangefinder into the accessory shoe on top of the camera, and sight the object and adjust the finder until the two outlines fuse into one. The focusing disc on top of the RETINA *Close-Up Rangefinder* then indicates which supplementary lens is to be used, and the distance setting required. The N 1 supplementary lens carries one ring engraved on the mount, the N 2 two rings, and the two lenses screwed together cover a third range ($N 1 + N 2 = 3$ rings).

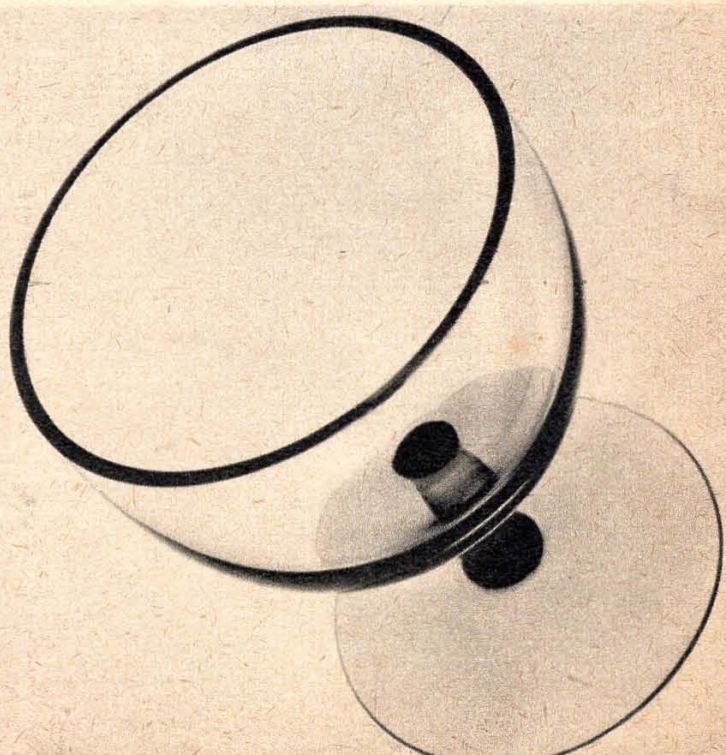

THE RETINA CLOSE-UP ATTACHMENT

The *Retina Close-Up Attachment*, together with the supplementary R lenses (R 1 : 2, R 1 : 3, and R 1 : 4,5) is a most useful accessory for taking shots of small live animals or other subjects at a distance of 6 to 11 inches (15 to 28.5 cm). The advantage of this method of taking close-ups lies in the fact that you have neither to measure the distance nor to focus. The approximate size of the subject area covered with the R lenses is as follows: with the R 1 : 2 about 2×3 inches (52×74 mm), with R 1 : 3 about 3×4 inches (74×105 mm), and with the R 1 : 4.5 about 4×6 inches (105×148 mm). The two lenses R 1:2 and R 1:4.5 combined yield a fourth and largest scale of reproduction of 1:1.5 with a subject area of about 1½×2 inches (37×52 mm). In practice, the four scales of reproduction will be found sufficient for most close-up subjects. Combined with the RETINA lenses, the supplementary R lenses (which are also suitable for copying) provide excellent results since they are highly corrected and carefully adjusted to match the RETINA lenses.

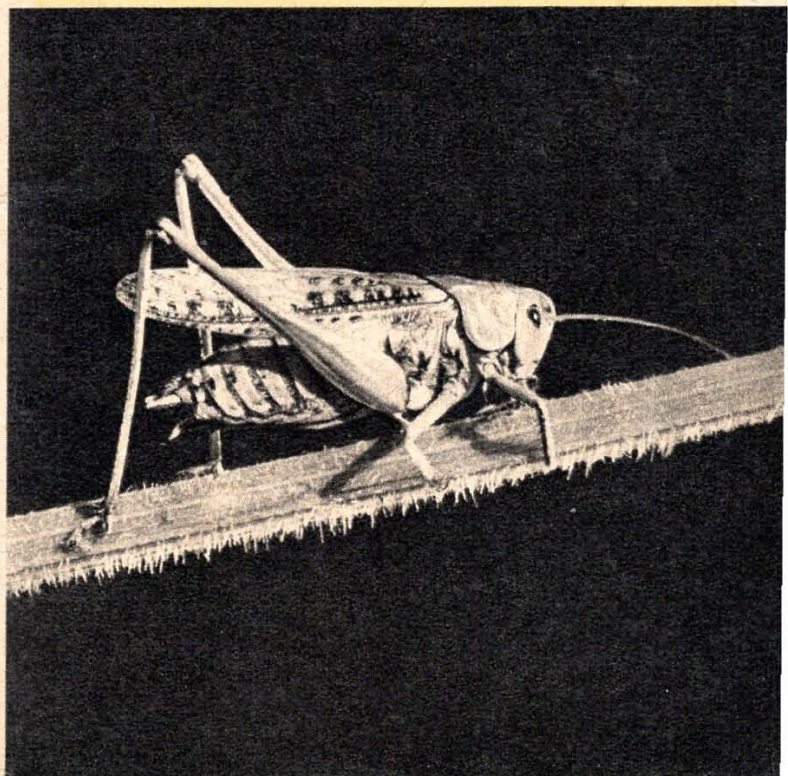
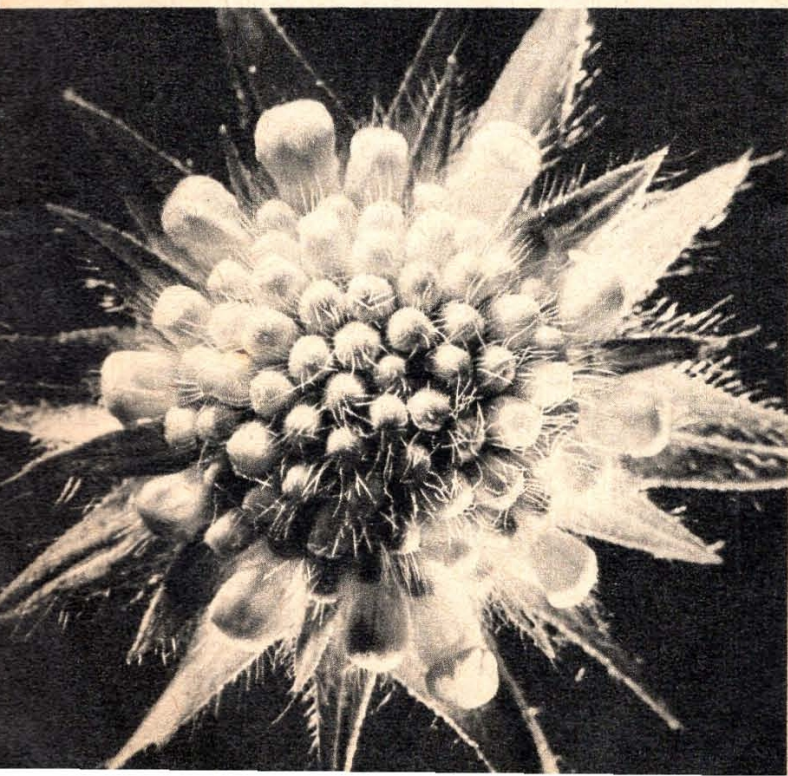
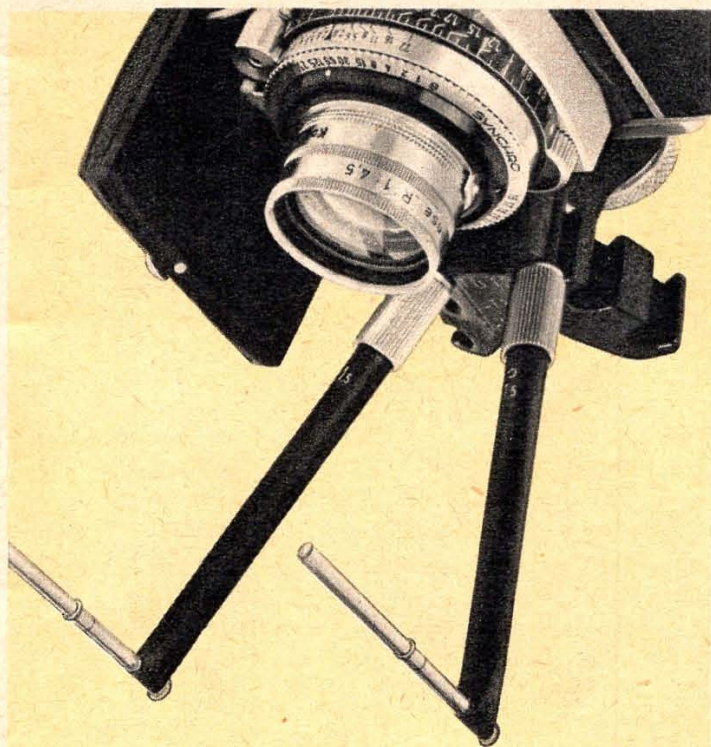

Many interesting photographs can be quickly and easily taken with the table stand. It may be used together with the *Retina Close-Up Rangefinder* and the supplementary N lenses, or with the *Retina Close-Up Attachment* and the R lenses and permits time exposures of any length of all kinds of subjects. The versatile *Retina Table Stand* with its many applications is always a ready helper for the philatelist wanting to photograph the showpieces of his collection, the scientist needing records of specially valuable small objects, inscriptions, fossils, etc., or the amateur, hobbyist or artist just wanting to photograph something that interests him. Dismantled, the table stand can be carried comfortably in a rief case and it takes only a few moments to reassemble. The construction of the components of the table stand is so ingenious that it can be used in quite a number of combination. Vertical photographs from above or below and oblique shots are just as easy with the *Retina Close-Up Rangefinder* as vertical shots with the *Retina Close-Up Attachment* and the R lenses. The table stand makes it possible to use long time exposure at small apertures, thus achieving great depth of field to show up form, texture, and detail of very small objects, such as metal parts, textile samples, plants, objects d'art, jewellery, etc.

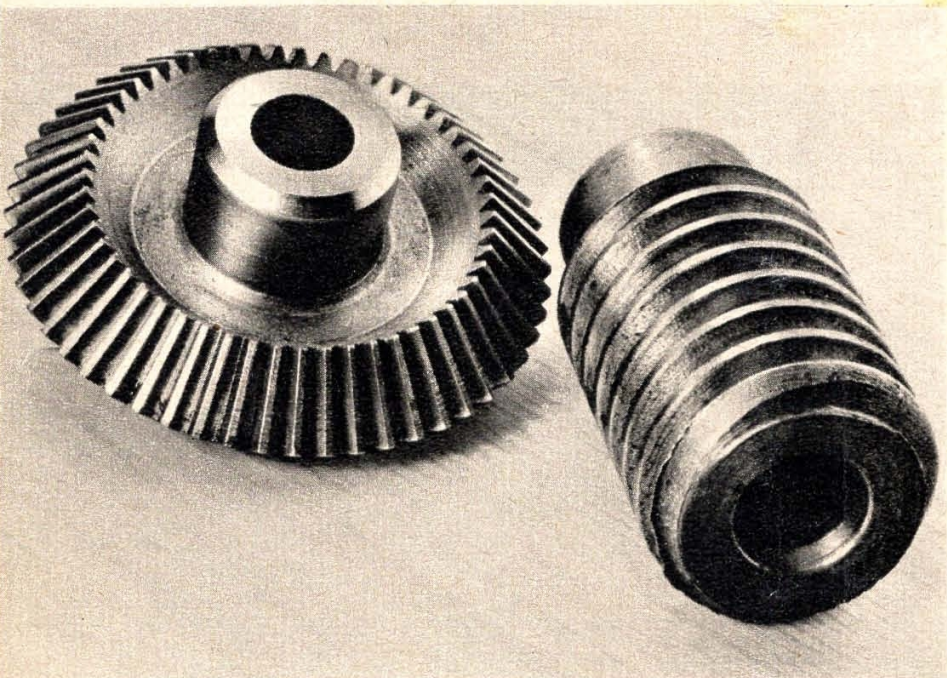

THE RETINA TABLE STAND

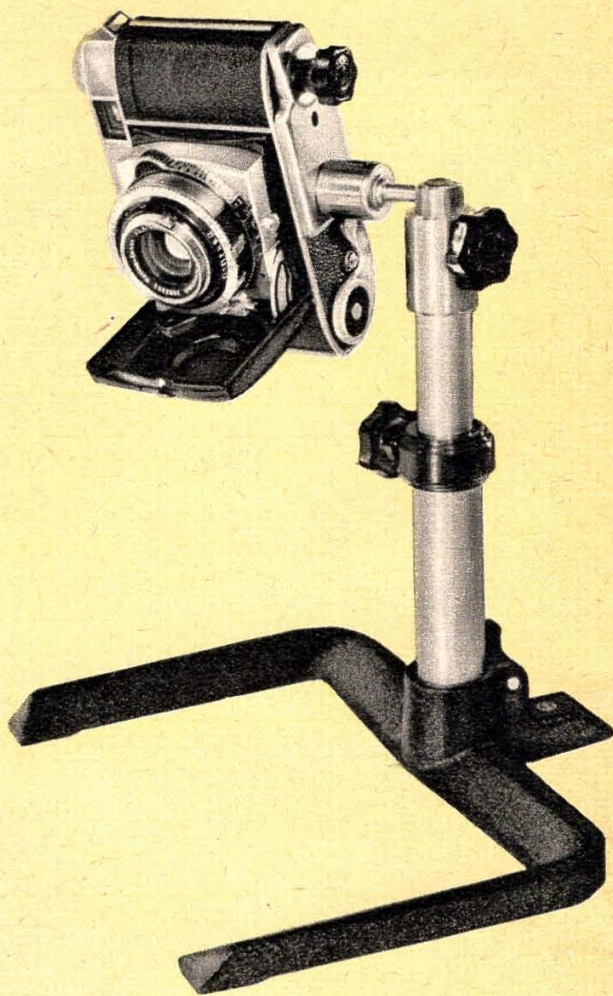

THE RETINA COPYING STAND

By means of the RETINA, the *Retina Copying Stand*, and the N 2 supplementary lens, members of many professions, scientists, art historians, architects, technologists and students, or amateurs, with a hobby such as collecting rare books or old prints, can quickly make reproductions of flat originals



of $8\frac{1}{4} \times 4\frac{1}{4}$ inches (21×10 cm) and $11\frac{3}{4} \times 8\frac{1}{4}$ inches (30×21 cm).

Provision is also made for fitting a supplementary lighting set, consisting of two lamps and lampholders, to the copying stand. The stand is light and quickly assembled. It is easy to carry with its accessories and it can quickly be erected in museums, public libraries, etc.

The advantage of the copying stand is obvious: with its help, the RETINA quickly copies all kinds of originals. You can also photograph your own personal documents to protect yourself against possible loss.

THE RETINA GROUND GLASS FOCUSING DEVICE

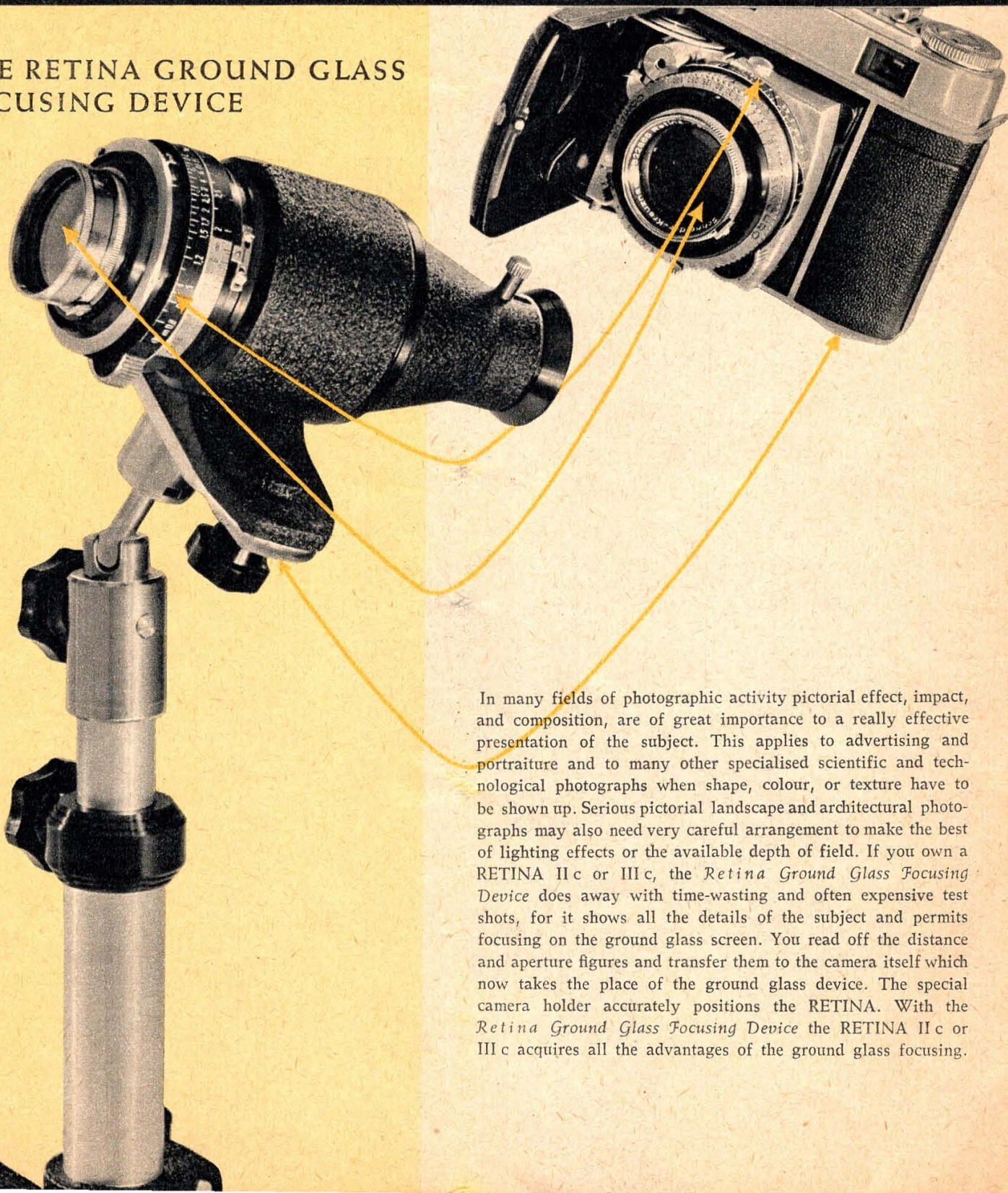

In many fields of photographic activity pictorial effect, impact, and composition, are of great importance to a really effective presentation of the subject. This applies to advertising and portraiture and to many other specialised scientific and technological photographs when shape, colour, or texture have to be shown up. Serious pictorial landscape and architectural photographs may also need very careful arrangement to make the best of lighting effects or the available depth of field. If you own a RETINA IIc or IIIc, the *Retina Ground Glass Focusing Device* does away with time-wasting and often expensive test shots, for it shows all the details of the subject and permits focusing on the ground glass screen. You read off the distance and aperture figures and transfer them to the camera itself which now takes the place of the ground glass device. The special camera holder accurately positions the RETINA. With the *Retina Ground Glass Focusing Device* the RETINA IIc or IIIc acquires all the advantages of the ground glass focusing.

THE RETINA- MICRO-ADAPTER

The *Retina-Micro-Adapter* extends the scope of the RETINA to photomicrography. It can be used with any RETINA with coated standard lens. Doctors, chemists, biologists, technologists, etc., use the *Retina-Micro-Adapter* to widen the range of their professional and scientific work.

The object can be watched and depth of field controlled through the focusing eyepiece of the *Retina-Micro-Adapter* even during the actual exposure. The scale of reproduction is one fifth of the visual image so that a $5\times$ enlarged print corresponds to the enlargement provided by the microscope. But the fine definition typical of the RETINA lenses allows greater enlargements with ease.

The aperture locking ring of the *Retina-Micro-Adapter* releases the coupling of shutter speed and aperture. This is necessary because the camera must be used at full aperture. The shutter speeds can be easily read through a mirror.

The locking knob secures the *Retina-Micro-Adapter* to the eyepiece of the microscope.

The clamping ring prevents the drawtube from slipping down. A special holder with an accessory shoe permits the use of the KODALUX L exposure meter. It fits over the adapter ring in place of the *Retina-Micro-Adapter*.

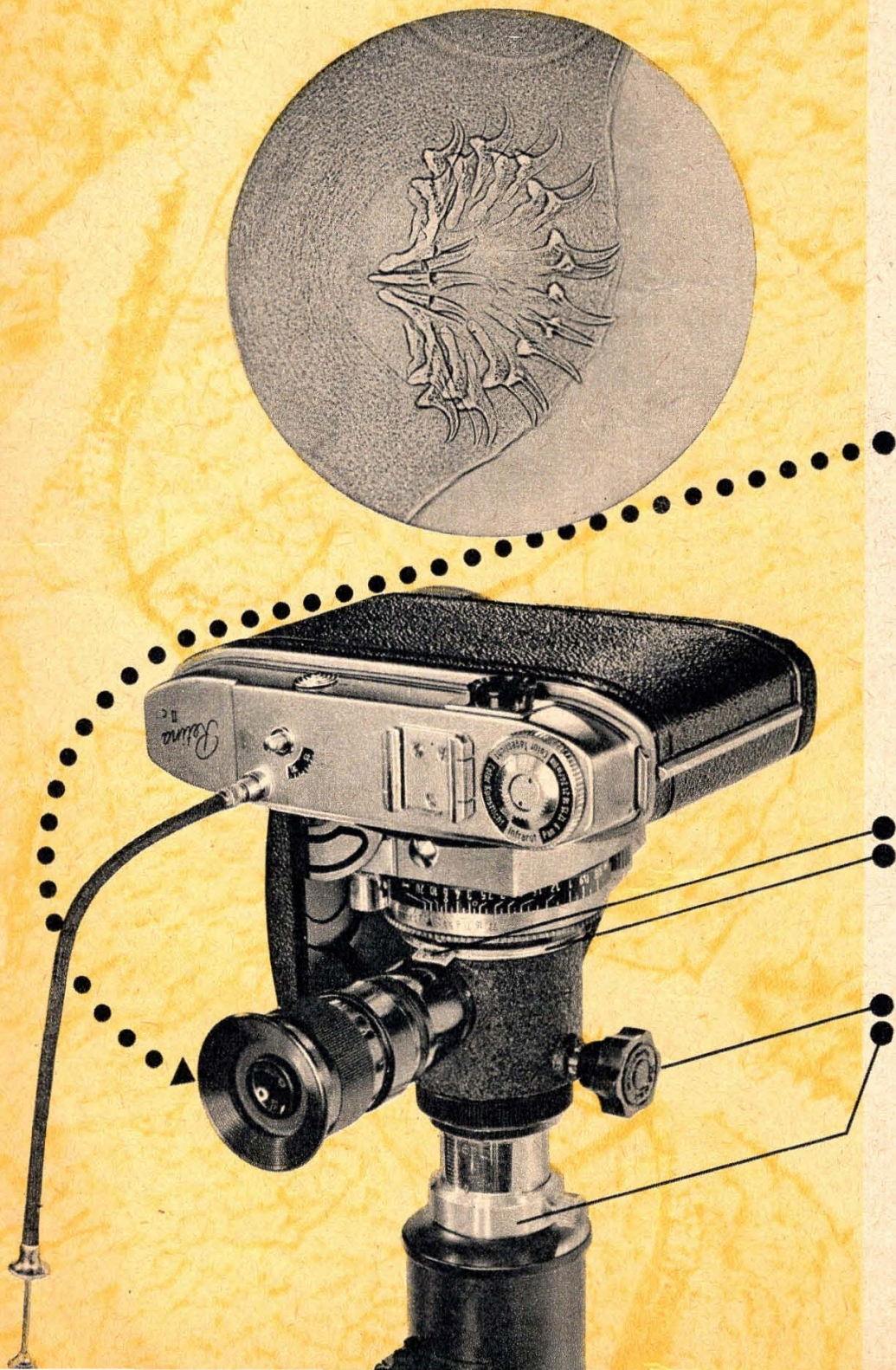



THE RETINA- STEREO-ATTACHMENT

To see correctly means to see in depth. The two healthy eyes of human beings see everything in three dimensions. A 3 D photograph is only possible if the camera "sees" with two eyes as well. The *Retina-Stereo-Attachment* turns the "one-eyed" RETINA II c and III c into a stereo camera. It is a handy and inexpensive accessory needing neither long preparations nor special knowledge.

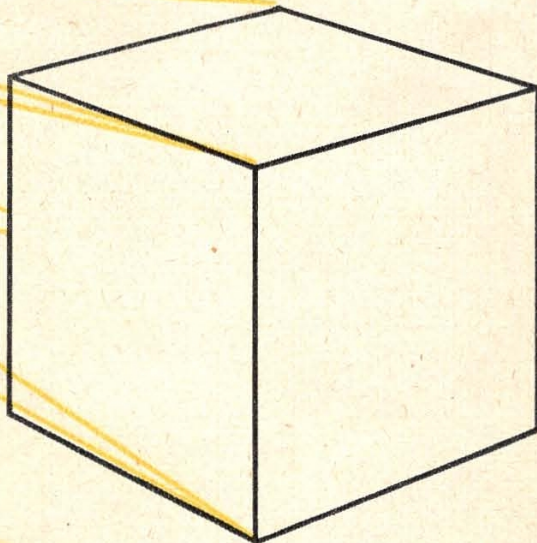

The *Retina-Stereo-Attachment* is fitted to the standard lens of the RETINA in a matter of seconds, making the camera "sees" in three dimensions. The attachment projects two vertical images on the RETINA film. These differ only in their viewpoints which are the same distance apart as our two eyes. Three-dimensional pictures are amazingly life-like. Stereophotography is not just a matter of private pleasure, to be used for holiday or sports pictures; technology and science also make increasing use of it for demonstration. Soon 3-D pictures will be indispensable for most professional workers, such as architects, engineers, interior decorators etc.

THE RETINA- STEREO-VIEWER

The *Retina-Stereo-Viewer* transmits the full impact of your stereo pictures. Coloured stereo pictures in particular (taken on Kodachrome film) give the viewer an impression of standing bodily in front of the subject, for the *Retina-Stereo-Viewer* shows the subject in about natural size, with all the brilliance of the colours rendered incomparably faithfully and perfectly by your KODACHROME film. Taking 3D pictures in colour entails no extra work or expense. The KODAK processing station mounts 3D KODACHROME transparencies in special 3D slides at no extra cost (right). Naturally, you can also use black-and-white reversal film for taking and viewing 3D pictures.

Your holiday and travel pictures, taken with the RETINA IIc or IIIc and the *Retina-Stereo-Attachment*, will always bring back your treasured memories.

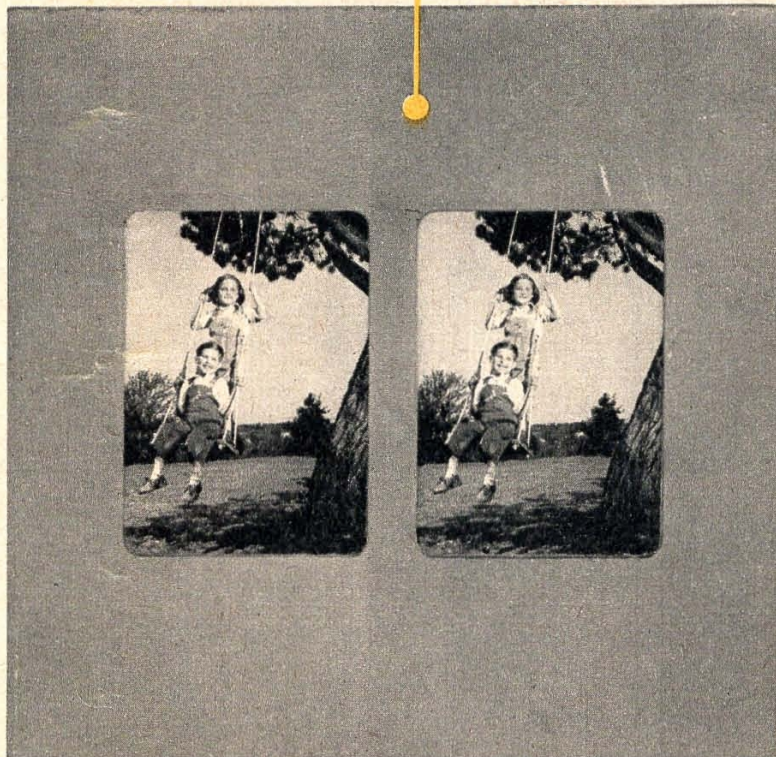
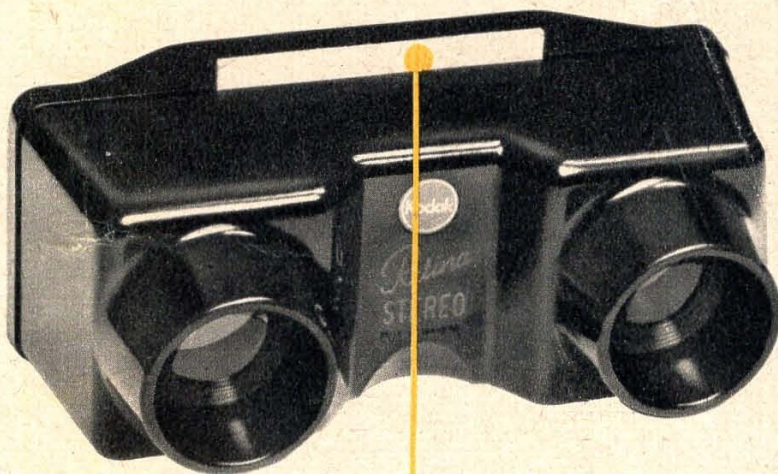

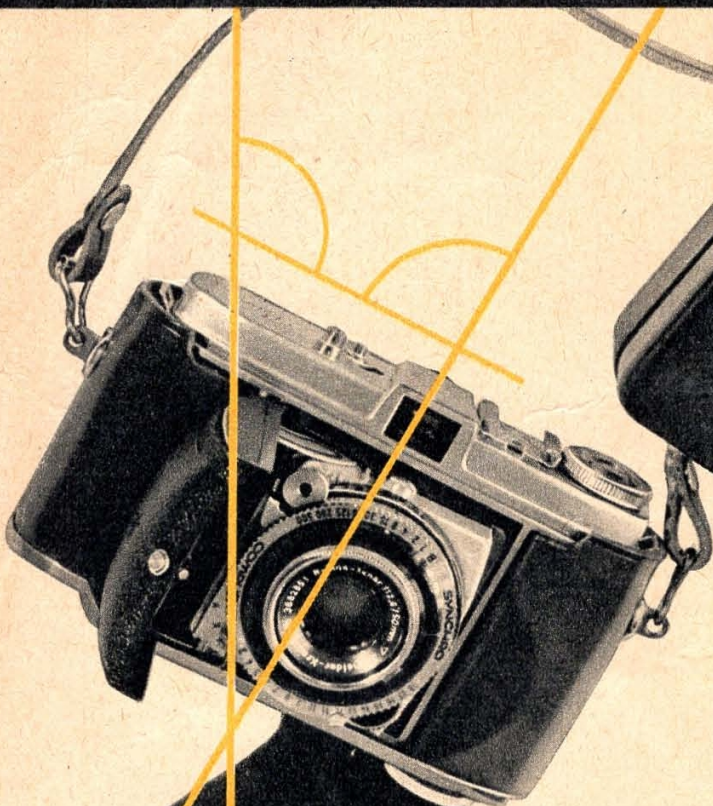

RETINA EVER-READY CASES

The purpose of an Ever-Ready Case is to make the camera always ready for action yet keep it well protected. The lid must not get in the way when open, nor the case prevent free manipulation of the camera controls. The smart ever-ready case of the RETINA meets all these demands. When open, the lid is never in the way, whether the camera is held horizontally or upright, for it always swings downwards. It can also be removed altogether. Every control is freely accessible. Besides, the adjustable carrying straps can also be attached to the metal carrying loops on the camera itself.

For those who do not wish to acquire the leather ever-ready case, there is also a plastic case which equally protects the camera in inclement weather. Special cases are available for the RETINA and its accessories as needed for the various kinds of photographic work. They carry the complete outfits neatly arranged in the smallest possible space.

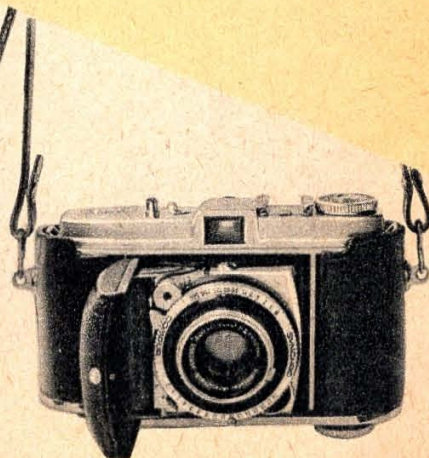
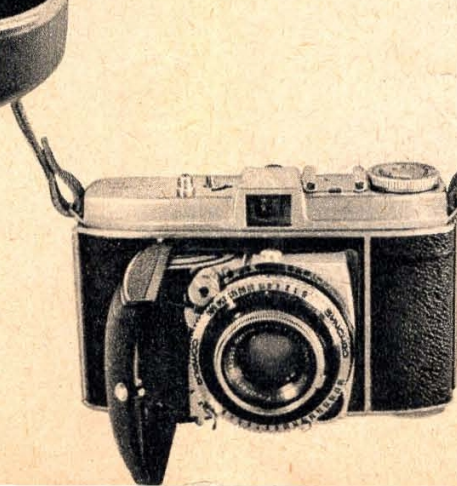
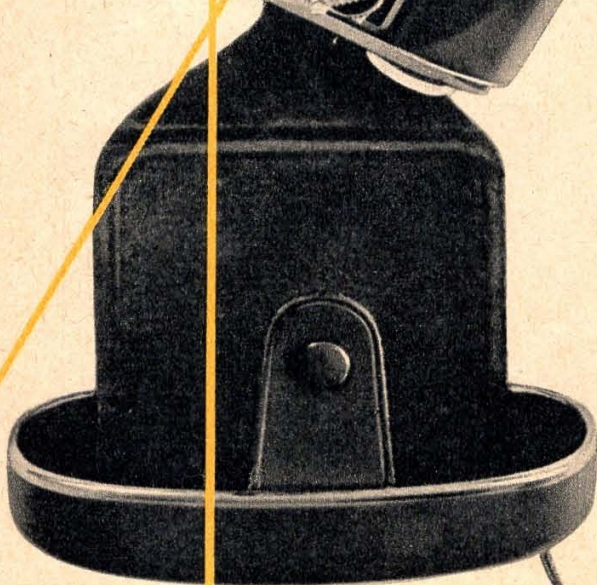

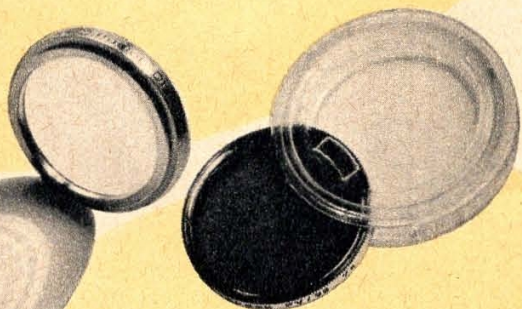
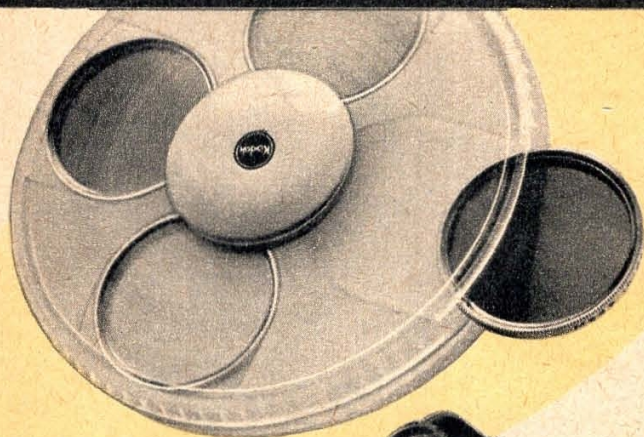

KODAK FILTERS

Quite a number of amateurs still wonder why their friends should bring home so much more effective pictures than they do. The secret is in the *Retina Colour Filters*. The various filters of the RETINA modify the tone reproduction of the film or achieve special pictorial effects. The *UV Filter* keeps off the unwelcome ultra-violet rays which abound in high mountains and by the sea. With the *KODAK Photo-flood Filter* you can take artificial light photographs on daylight type colour film, while the *KODAK Daylight Filter* permits daylight photographs on artificial light type colour film (Kodachrome type "A"). The *Pola Filter* eliminates disturbing reflections from shiny surfaces.

THE DIFFUSION DISK

comes in useful whenever you want a soft pictorial effect instead of the usual sharp definition of the RETINA lenses.

THE RETINA LENS HOOD

Experienced photographers never take any photographs without a lens hood. They know that all light rays from outside the subject area must be screened off. In addition, the lens hood effectively protects the lens against rain, sand, and snow.

