

**RETINA**

**REFLEX GUIDE**



**RETINA REFLEX**

**RETINA REFLEX S**



# RETINA REFLEX GUIDE

*How to get  
the best out of your  
Retina Reflex and  
Retina Reflex S*

By W. D. EMANUEL



*THE FOCAL PRESS*

*London and New York*

# CONTENTS

	Page
<b>THE RETINA REFLEX</b> ... ..	4
The Lens ... ..	6
Coated Lenses ... ..	8
The Care of Lenses ... ..	8
Lens Hoods ... ..	9
The Shutter ... ..	9
Viewing and Focusing ... ..	12
 <b>HANDLING</b> ... ..	 15
Loading ... ..	15
Holding ... ..	16
Carrying ... ..	18
Shooting ... ..	18
Unloading... ..	20
Cutting Off Exposed Lengths ... ..	20
Changing Partly Exposed Films ... ..	22
The Film Release of the Retina Reflex ... ..	22
Double Exposures ... ..	24
 <b>RETINA REFLEX FILMS</b> ... ..	 25
Safelight ... ..	25
Handling, Winding and Trimming the Film ... ..	25
<i>Length of Film Required</i> ... ..	28
Loading Retina Reflex Cassettes ... ..	28
Loading Cassettes with Darkroom Film ... ..	29
Loading Cassettes with Daylight Refills ... ..	29
The Choice of Black-and-White Material ... ..	30
<i>Conversion Table of Speed Degrees</i> ... ..	32
<i>Characteristics of Some 35 mm. Films</i> ... ..	49
Colour Film ... ..	50
<i>35 mm. Colour Films on the Market</i> ... ..	51
 <b>RETINA REFLEX LENSES</b> ... ..	 53
Changing the Lenses ... ..	53
Focusing with the Interchangeable Lenses ... ..	54
Close-ups with the Telephoto C Lens ... ..	56
Exposures with the Interchangeable Lenses ... ..	58

	Page
<b>FOCUSING</b> ... ..	59
Control of Depth of Field ... ..	59
Depth with the Wide-angle and Tele Lenses ... ..	62
Quick Focusing ... ..	62
<i>Hyperfocal Distances</i> ... ..	63
<i>Zone Focusing</i> ... ..	63
The Depth of Field Tables ... ..	64
<i>Depth of Field for the Standard 5 cm. Lens</i> ... ..	65
<i>Depth of Field for the 8-8.5 cm. Lenses</i> ... ..	66
<i>Depth of Field for the 13.5 cm. Lenses</i> ... ..	67
<i>Depth of Field for the 2.8 cm. Lenses</i> ... ..	68
<i>Depth of Field for the 3.5 cm. Lenses</i> ... ..	69
<b>EXPOSURE</b> ... ..	70
Using the Exposure Meter of the Standard Reflex ... ..	70
Using the Coupled Meter of the Retina Reflex S ... ..	70
Working with an Exposure Meter ... ..	72
<i>Exposure Table for Daylight</i> ... ..	74
<b>USING FILTERS</b> ... ..	76
<i>Factors with Retina Reflex Filters</i> ... ..	77
Polarizing Filter ... ..	78
<b>CLOSE-UP WORK</b> ... ..	79
Supplementary Lenses ... ..	79
<i>Close-up Focusing Table for +1, +2, +3 Diopter Lenses</i> ... ..	80
The Close-up Attachment ... ..	82
The Table Stand ... ..	82
<i>Close-up Focusing Table for Retina Reflex Supplementary Lenses</i> ... ..	83
The Copying Stand ... ..	84
The Micro-adaptor ... ..	84
The Stereo Attachment ... ..	84
<i>Close-up Depth of Field Table</i> ... ..	86
<b>FLASH PHOTOGRAPHY</b> ... ..	88
How To Use Flash ... ..	90
The Correct Aperture ... ..	91
Guide Numbers ... ..	91
<i>Synchronized Shutter Speeds</i> ... ..	92
<i>Apertures with Clear Flash Bulbs</i> ... ..	92
<i>Apertures with Blue Flash Bulbs</i> ... ..	92
<b>CONVERSION OF FEET AND INCHES INTO METRIC UNITS</b> ... ..	94
<b>HOW TO ...</b> ... ..	95
<b>WHAT IS WHERE?</b> ... ..	95

## THE RETINA REFLEX

The Retina Reflex is an eye-level 35 mm. reflex camera with interchangeable lenses for all general photography as well as technical work, copying, photomicrography, stereo photography, etc. In many of these fields the ground-glass screen is a distinct advantage. The camera takes normal 35 mm. perforated film and produces a negative size  $24 \times 36$  mm. ( $1 \times 1\frac{1}{2}$  in.). For special applications a range of accessories is available for the camera.

The viewing system consists of a 45-degree mirror which throws the image formed by the lens on to a ground glass screen on top of the camera. A pentaprism permits observation of this image—which appears upright and the right way round—at eye-level.

The centre of the focusing screen is taken up by a pair of crossed wedges which are set in the screen and act as a split image rangefinder. As long as the image is not accurately focused, it appears blurred on the screen itself, while the wedges split it into two clear halves displaced relative to each other. These are thus two alternative methods of checking the exact focus.

For the exposure the mirror swings out of the way together with a light-tight capping plate in front of the film aperture, thus leaving the way free for the lens to form its image on the film. This image exactly corresponds in sharpness and field to the screen image which is absolutely free from parallax irrespective of the lens or lens attachment used.

In order to permit observation of the image, the shutter is open while the mirror is in the viewing position. On pressing the release button the shutter closes while the mirror and capping plate fold away, and then opens and closes again to take the picture.

The mirror and capping plate are also linked to the transport mechanism. This is operated by the same type of rapid winding lever fitted on the folding Retina models. In addition  
4 to advancing the film, the rapid winding lever closes the

capping plate, brings down the mirror into the viewing position, advances the film counter, and tensions and opens the shutter for viewing.

The film transport acts directly on the sprocket which pulls the film through the camera, and is also linked to the friction-driven take-up spool. A double exposure and blank frame lock locks the transport after each frame until freed by the shutter release; the latter is locked after each exposure until the film has been advanced again.

A film release button is built in and frees the transport lock for advancing the film without exposing. This permits reloading of partly exposed films. The film release button incorporates a guard to prevent accidental operation.

Two types of lens system are available. On the standard Retina Reflex the front unit is interchangeable and can be changed for a wide-angle or telephoto unit, while the rear component is firmly mounted behind the shutter blades. On the Retina Reflex S the whole lens is mounted interchangeably in front of the shutter. Each lens, in this case, has an automatic depth of field indicator.

The shutter is a Synchro-Compur (with light value scale on the standard model) and coupled aperture and speed settings. It is MX-synchronized with built-in self-timer; the synchronizing lever can only be adjusted after releasing a safety lock which prevents inadvertent change of setting.

A photo-electric exposure meter is built into the body at the right-hand (transport) end of the camera. On the Retina Reflex this works on the principle of a travelling marker—which has to be set to the needle position—and directly indicates light values. The meter of the Retina Reflex S is directly coupled to the aperture setting. A diffusing disc is available to fit over the cell for incident light readings.

The camera back is hinged at one end; a special safety device prevents accidental opening. The pressure plate does not press the film directly against the track, but leaves a very thin channel for the film. This design has been found to hold the film flatter than any other method.

The Retina Reflex will accept most of the accessories made for the Retina IIC and IIIC cameras, including (for the standard model) the wide-angle and telephoto lens units (see p. 53). The lenses of the Retina Reflex S are interchangeable with the Retina III S lenses.

The Retina Reflex camera was first introduced on to the market during 1957, the Retina Reflex S with coupled exposure meter in 1959.

## The Lens

The Retina Reflex S is available with the 2 in. (5 cm.) Retina Xenar  $f2.8$  Retina Ysarex  $f2.8$  or the ultra-fast Retina Xenon  $f1.9$  or Retina Heligon  $f1.9$  as standard lenses.

The Retina Reflex is fitted with the Retina-Xenon  $f2$  2 in. (5 cm.) or the Retina Heligon  $f2$  2 in. (5 cm.).

The Xenar and Ysarex are four-component triplet types of high quality; the Xenon and Heligon lenses consist of six elements and are of

---

**The parts and controls of the Retina Reflex are as follows: —————>**

**Lens:** L4, aperture scale; L5, lens changing mount (Reflex S); L6, lens changing catch; L9, interchangeable front component (Reflex only).

**Focusing:** F1, focusing mount (Reflex) or knob (Reflex S); F2, distance scale; F3, depth of field scale (Reflex) or automatic indicator (Reflex S).

**Shutter:** S2, release button; S4, shutter speed scale; S6, light value control (Reflex only); S7, S7a, synchronizing lever; S7b, synchronizing lock; S8, shutter speed ring (Reflex); S9, flash socket; S10, cable release socket in release button.

**Exposure meter:** E2, meter cell; E4, meter setting ring (Reflex), or wheel (Reflex S, coupled with aperture control); E5, light value readings (Reflex only); E6, film speed setting controls; E7, meter needle; E8, setting marker.

**Viewfinder:** V2, eye-level finder eyepiece; V5, pentaprism housing.

**Film and transport:** T1, rapid winding lever; T4, film counter; T5, film counter setting button; T6, film type indicator; T7, rewind knob; T8, reversing button; T9, film release.

**Body:** B3, back lock with safety device; B8, accessory shoe; B11, eyelet for carrying strap.

**Top left:** General view of Retina Reflex against a 1 in. scale grid. **Top right:** Top view of Retina Reflex. **Centre right:** Front view of Retina Reflex. **Bottom right:** Front view of Retina Reflex S. **Centre left:** Top view of lens and shutter controls of Retina Reflex S. **Bottom left:** Top view of exposure meter details on Retina Reflex S.

# THE RETINA REFLEX

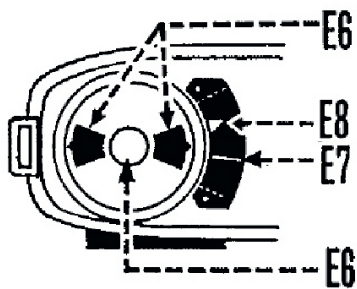
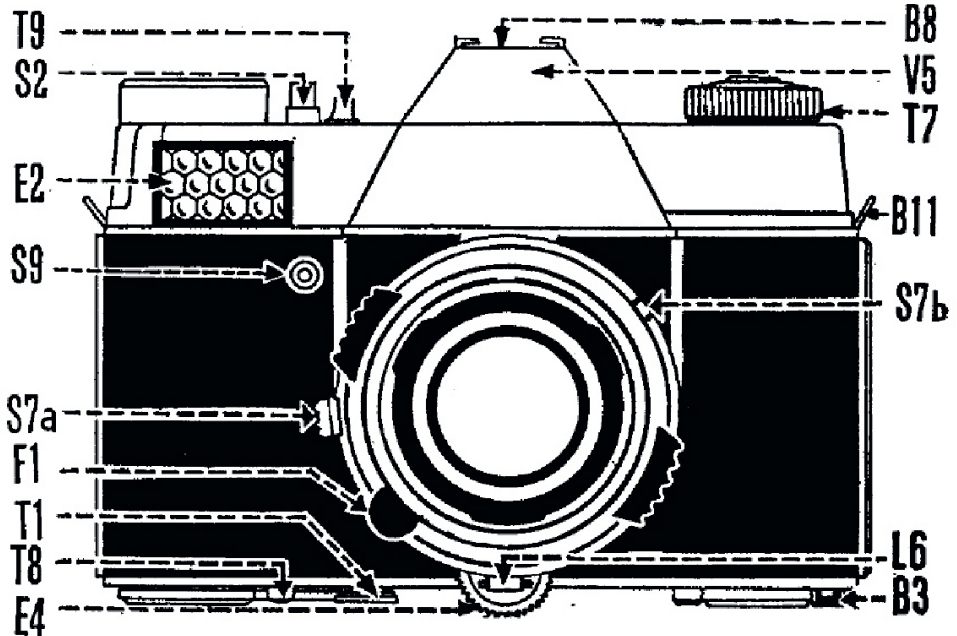
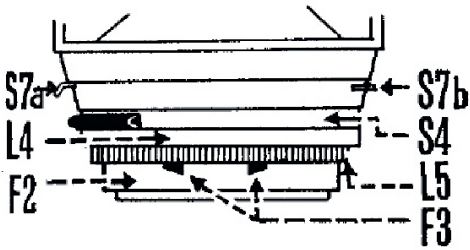
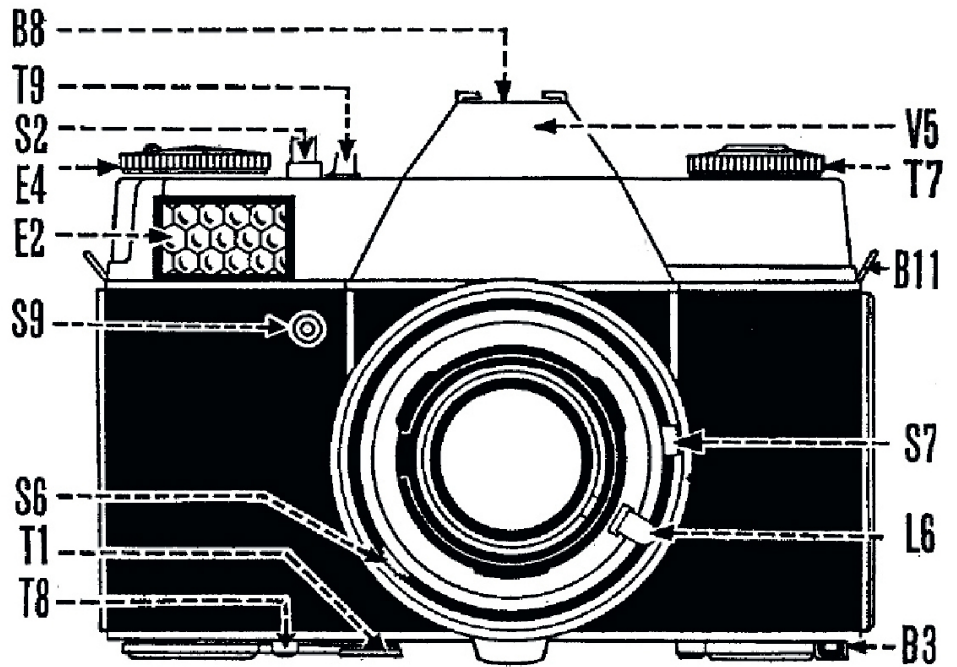
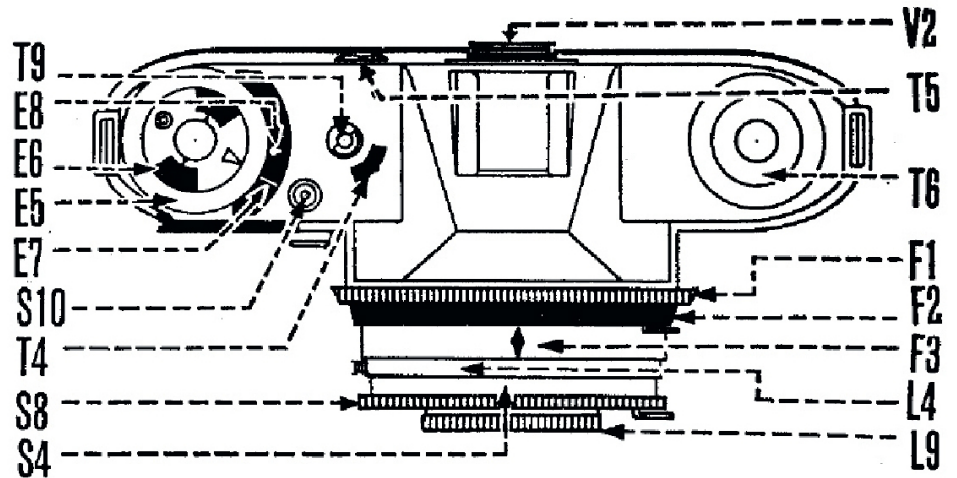
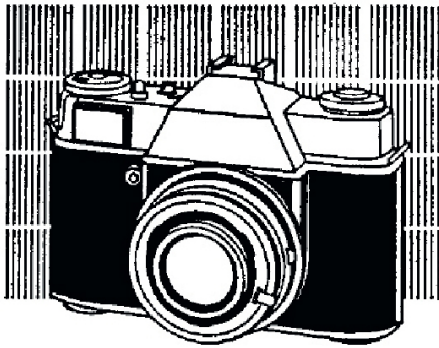

symmetrical four-component design. They have an angle of view of  $47^\circ$ , and are in a helical focusing mount. They permit focusing from infinity down to  $2\frac{1}{2}$  ft. The focusing range of the  $f/2$  lenses of the Retina Reflex and  $f/2.8$  lenses of the Reflex S (but not the  $f/1.9$  lenses of the Reflex S) can be extended down to approximately 9 in. with the aid of supplementary meniscus lenses (see page 79).

Both Retina-Xenon and Retina-Heligon lenses are of highest performance. They give critical definition at full aperture and this can be improved to reach optimum definition on stopping down to  $f/5.6$ . They show very good colour correction, flatness of field and resolution. Even at full aperture the whole of the negative field is fully covered and evenly illuminated. Both are fast universal lenses, suitable for photography in poor light of fast-moving objects, portrait, architectural, as well as all general photography, the  $f/1.9$  lenses of the S model being slightly faster (some 11 per cent) than the  $f/2$  lenses.

The characteristics and performance of the Xenar and Ysarex are similar to the Xenon and Heligon described above; they have approximately half their maximum speed and are therefore somewhat less suitable for photography in poor light. Both the Retina Xenar  $f/2.8$  and Retina Ysarex  $f/2.8$  can be used with the Retina close-up lenses (see page 79).

The front component of the standard lens of the Retina Reflex is interchangeable, enabling telephoto and wide-angle units to be used (see page 53). On the Retina Reflex S the complete lens is interchangeable, giving a wider range of focal lengths. Reflex S lenses cannot, however, be used on the standard Reflex or vice versa.

## Coated Lenses

The lenses used in the Retina Reflex cameras are coated. Coating, or as it is sometimes called, blooming, consists of the application of a microscopically fine film of magnesium fluoride on the lens surfaces which considerably reduces the light reflection at glass and air surfaces in the lens. For example, in a six-element  $f/2$  lens of the Xenon type the loss of light due to surface reflection is in the region of about 40 per cent, a figure which is reduced by coating to about 5 per cent. Apart from a gain in the speed of the lens which may in actual practice be as much as 50 per cent (= half a stop), coating reduces the scatter of light which impairs the contrast of the image. This results in a more brilliant negative, specially in the shadow regions where the tones are most subdued, and so brilliance and contrast are most needed. The fact that a lens has been coated can be recognized by observing in the lens reflections of, let us say, a lamp which appear distinctly coloured, as a rule a rather deep blue with a tinge of red.

## The Care of Lenses

8 The treatment and care of lenses is important. On account of its chemical composition, high quality optical glass is

susceptible to the influence of moisture, and for this reason one should never touch the glass with the fingers. Since complete protection is impossible, clean the lens surface occasionally with a clean, soft chamois leather. Grease, rain spots, etc., may be removed with a pad of cotton-wool moistened in ether. Neither glass nor the coating film will be affected by this treatment.

## Lens Hoods

The lens hood is a tube placed over the front of the lens to protect it from light coming from outside the actual picture area. There is no picture which could not be improved in clarity and brilliance by the use of a lens hood. The wider the aperture of the lens, the more important is the use of the lens hood. When strong light coming from objects outside the actual picture area strikes the lens, it considerably reduces the brilliance of the picture. This applies not only to photographs taken against the light—when the lens hood becomes indispensable—but also to sunshine in general.

The Retina Reflex lens hood is rectangular with a tubular bayonet fitting at the back. It is made of plastic and fits into the bayonet mount surrounding the lens itself. For use with the wide-angle and telephoto lenses, round push-on hoods are available.

## The Shutter

The shutter is the Synchro-Compur MXV. It has the speeds 1,  $\frac{1}{2}$ ,  $\frac{1}{4}$ ,  $\frac{1}{8}$ ,  $\frac{1}{15}$ ,  $\frac{1}{30}$ ,  $\frac{1}{60}$ ,  $\frac{1}{125}$ ,  $\frac{1}{250}$ ,  $\frac{1}{500}$  sec. and B for time exposures. It is synchronized for flash bulbs and electronic flash and has a built-in delayed-action device (self-timer) for self-portraits.

On the Retina Reflex the shutter has a light value scale, on the Reflex S the exposure meter is coupled with the aperture scale. In both cases aperture and speed settings are coupled.

The shutter speeds are engraved in black behind the front serrated rim, the shutter setting ring. The figures 1, 2, 4, 8, 15, 30, 60, 125, 250, 500 represent fractions of seconds and therefore stand for 1,  $\frac{1}{2}$ ,  $\frac{1}{4}$ ,  $\frac{1}{8}$ ,  $\frac{1}{15}$ ,  $\frac{1}{30}$ ,  $\frac{1}{60}$ ,  $\frac{1}{125}$ ,  $\frac{1}{250}$ ,  $\frac{1}{500}$  sec. respectively. The shutter speed should be set to the exact marked values, as intermediate setting would not give reliable intermediate values. The shutter speed may be set or changed any time before or after winding the film (which automatically tensions the shutter).

On the Retina Reflex the base of the shutter rim has a range of numbers (from 1 to 18) engraved in red which represent light values for correct exposure. Each light value represents a range of shutter speed-aperture combinations, but is covered by a single setting. The built-in exposure meter of the Retina Reflex camera is calibrated in light values; the reading can thus be transferred directly to the shutter.

To set the light value, slightly depress the serrated lever on the left of the shutter front and move the red dot beside it to the appropriate light value on the scale. Intermediate light values can also be set, e.g.,  $5\frac{1}{2}$ ,  $6\frac{1}{2}$ , etc., for fully accurate work. On the Retina Reflex S the operation of taking an exposure meter reading automatically sets the aperture (see page 71).

You can now choose any shutter speed or aperture without changing the exposure. If you alter the shutter speed, the aperture will set to the correct value, or if you change the aperture, the shutter speed adjusts itself automatically to keep the effective exposure constant. In every case the aperture remains fully open for viewing and closes down to the set value only on pressing the shutter release.

To change the shutter-aperture combination, just move the speed setting ring until the aperture lever or speed index points to the required aperture or shutter speed respectively.

The green figures on the exposure scale are for calculating time exposures. With the shutter speed ring set to B the green figures indicate the length in seconds of the exposure required and which stop to use. If, for example, at 1 sec. and  $f2.8$ , any of the following combinations may be used: 4 sec. at  $f5.6$ ; 8 sec. at  $f8$ ; 15 sec. at  $f11$ ; or 30 sec. at  $f16$ . Incidentally, there is no green number 2. Its place is taken up by B. When reading off full seconds, read 2 seconds for the B position. In the example above, if you want to use  $f4$  you would require 2 seconds.

The shutter may be used in the conventional way too; in this case, the shutter speed has to be adjusted first and then the aperture.

**FOR TIME EXPOSURES** turn the shutter setting ring until B (= brief time) points to the elongated diamond mark. On releasing, the shutter will remain open as long as the release button is pressed down and closes as soon as the pressure on the release is removed.

For such time exposures the camera must be mounted on a firm support such as a tripod.

It is safest to release the shutter with the help of a cable release to avoid shaking the camera. This release screws into the bush in the centre of the body release of the camera.

For the long time exposures—where the shutter is to remain open for longer than you can conveniently keep the release depressed—use a cable release with a lock. To make the exposure, set the shutter to B, and press the cable release plunger with the locking plate lifted. The shutter will now remain open until the locking plate is depressed. On cable releases with locking screws, tighten the screw on pressing the plunger and undo the screw to close the shutter.



THE DELAYED-ACTION RELEASE for self-portraits built into the Synchro-Compur MXV shutter is brought into action by moving the lever on the left of the shutter to V. This can only be done after the film has been transported and while depressing the small projecting stud let into the depth of field ring near the base of the camera. On pressing the release button with the lever set to V the shutter goes off after a delay of approximately 15 sec., giving the operator time to take his place in the picture. It goes without saying that the camera must be mounted on a rigid support, preferably a tripod. Once the lever has been set to V, the position cannot be altered any more. On releasing, the lever will automatically move back to the X position.

The X and M positions are for synchronizing flash with the camera. The Synchro-Compur shutter is fully synchronized for flash work (see p. 88).

## Viewing and Focusing

The image reflected by the lens on to the screen is only visible after winding the shutter. It disappears once the shutter is released. This indicates at the same time whether the camera is ready for the next exposure, as winding the shutter also advances the film.

The reflex image is large and brilliant and appears almost in natural size; it is free from parallax. A viewing pentaprism shows the image upright and right-way-round at eye-level.

The centre of the reflex finder image contains a clear circle. This centre circle is cut in half by a horizontal line and acts as a split image rangefinder. The distance to the subject can be measured in two ways.

First, by observing through the centre circle of the reflex finder a vertical line of the subject to be focused, e.g., a tree, edge of a wall, outline of a person and suchlike. On turning the camera focusing mount (the serrated ring on the lens mount nearest to the camera body) the image in the upper half moves in relation to the lower half of the circle. The lens is focused correctly when the two halves are exactly in line with each other. If the camera is held vertically, choose a horizontal line of the subject; the centre appears split vertically, otherwise the procedure is the same as described above.

**12** Alternatively, and particularly if the subject does not show any prominent vertical or horizontal lines, observe the image

## FOCUSING AND VIEWING

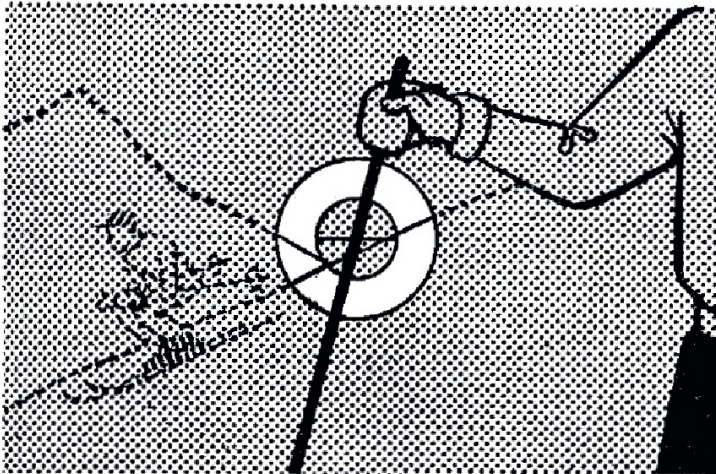

The centre of the viewing screen of the Retina Reflex carries a split image optical rangefinder which shows the incorrectly focused subject in two displaced halves (*right*). The remainder of the finder field constitutes a ground glass focusing screen. When the subject is accurately focused, it appears sharp on the screen and the two halves of the rangefinder image move together to form a continuous line (*above and extreme right*).

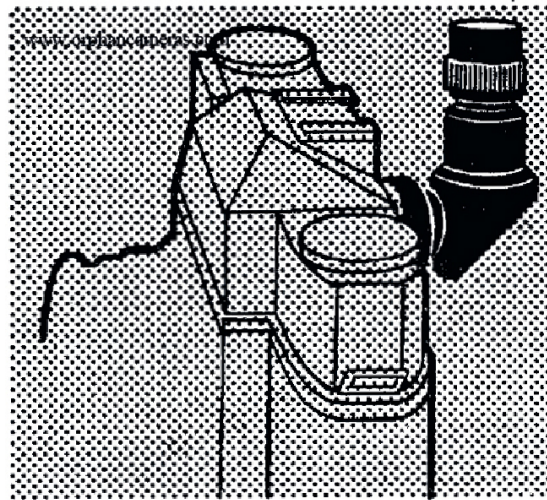
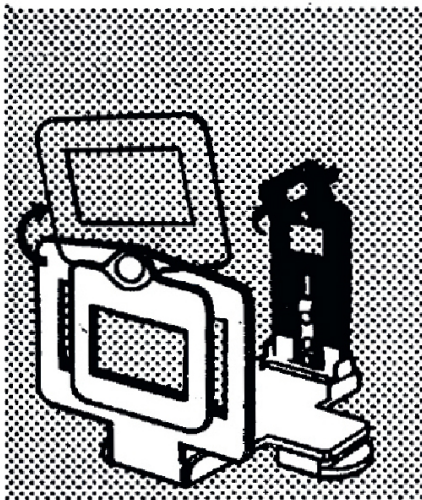
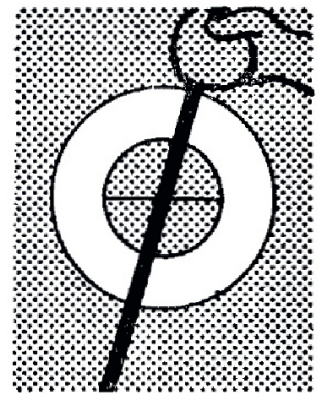
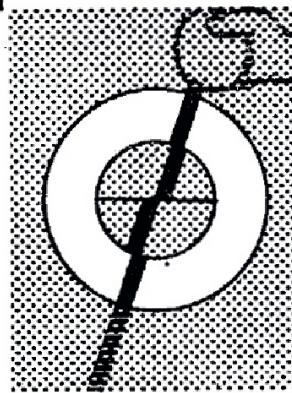

A folding frame finder (model C) can be fitted into the accessory shoe of the Retina Reflex (*left*). It is intended for use where it is desirable to be able to see the field of view immediately outside that of the viewfinder (e.g., in sports photography). The frame gives the field of view for the standard lens, and a masking device can be swung down to cover that of the telephoto lens. A right-angle finder (*right*) is useful for low angle views, copying and the like.

on the ground glass which surrounds the circle. Turn the lens mount until the image of the subject appears perfectly sharp on the ground glass.

Whilst focusing with the split image rangefinder is quite straightforward, some experience is required to obtain the best definition quickly when using the ground glass method. The best way to arrive at critical definition is to turn the focusing ring of the lens mount slowly to and fro while observing on the ground glass the subject to be focused. As you turn the focusing mount, the image becomes more and more sharp up to a certain point, beyond which it will again lose definition. At this "beyond" stage, turn the mount back again, narrowing down the degree of movement until you arrive at the point of best definition.

**RIGHT-ANGLE FINDER.** To tackle low angle views, subjects near the ground and copying, a right-angle viewfinder has been designed for the Retina Reflex. It fits over the viewfinder eyepiece and is held in position by a bayonet lock.

**FRAME FINDER MODEL C.** A folding frame finder (model C) is also available for the Retina Reflex. This fits into the accessory shoe of the camera and is intended for shooting fast-moving subjects, architectural studies or any shot where it is desirable to be able to see the field of view immediately outside that of the viewfinder. Its frame gives the correct field of view for the standard lens and a masking device can be swung into position to cover the field of the telephoto lens. Parallax adjustment for close-range work is provided.

The orthodox way of focusing with either split field range-finder or ground glass may be adopted for taking photographs of subjects that are fairly stationary. A different method of focusing is required when taking subjects in motion. Set the split image rangefinder circle to a distance at which the subject will be at a given moment, or focus at some spot which it actually has to pass, and press the release button when the subject reaches the pre-focused point. With subjects liable to react self-consciously (e.g., children), set the lens to a suitable distance, and then approach the subject quickly, exposing as soon as the ground glass image appears sharp or the two halves of the rangefinder are in line.

Alternatively, focus on some object which is at the same distance from the camera as the subject, but in a different direction. When the range is found, swing round and press the release button as soon as the victim appears in the finder. See also p. 63 for quick shooting with zone focusing.

## HANDLING

*Where the manipulation differs from the standard Retina Reflex and Retina Reflex S, the two models are mentioned separately. In all other cases, "Retina Reflex" refers to both models.*

Our first task is to load the camera with film. This should be done in subdued light (e.g., in the shade).

### Loading

- 1. Open back.**
  - 2. Pull out film-rewind knob.**
  - 3. Insert cassette with film in film chamber.**
  - 4. Push film-rewind knob back.**
  - 5. Thread the film end into the slit of take-up spool.**
  - 6. Close camera back.**
  - 7. Set exposure counter.**
  - 8. Set film indicator and film speed on the exposure meter.**
- 1. Turn the double lever surrounding the tripod bush on the camera base in the direction of the arrow. Then press the little button underneath the lever, and the back will spring open.**
  - 2. Pull out the milled knob above the empty film chamber fully to its second stop.**
  - 3. Insert film cassette so that projecting spool peg lies in the recess in the bottom of the spool chamber.**
  - 5. Pull out about  $3\frac{1}{2}$  in. of film from the cassette; turn the built-in take-up spool so that the slot faces the camera back. Push the film end into the slot so as to anchor a perforation hole in the small hook of the slot. Turn the serrated take-up spool flange until the film slack is taken up. It should lie flat across the film aperture, and the "teeth" of the sprocket wheel engage in the lower row of perforations of the film. Not less than two perforation holes of the upper row of perforations should overlap the film track.**
  - 6. The camera back is closed by pressing the back against the body until the catch engages.**
  - 7. Push the exposure counter setting knob at the right of the viewfinder in the direction of the engraved arrow, while at the same time pressing the film release button behind the exposure counting window. Keep pushing the setting knob over until the diamond mark (◆) between the number and 36 in the exposure counter is opposite the notch in the window. If a 20-exposure film is used the diamond mark between the numbers 20 and 25 should be set to the notch.**

Now turn the rapid winding lever and press down the film release button. Repeat these two operations until the exposure counter indicates No. 36 or 20. The counter registers the number of frames still unexposed. Incidentally, the film release button has a half shield as a safeguard to prevent accidental use or confusion with the shutter release button.

8. The film indicator on top of the rewind knob is marked with various types of films available. Grip the rewind knob with two fingers and turn the inner serrated ring with your fingertip until the triangular index mark (▼) points to the type or speed of film loaded into the camera. This acts as an aid to your memory. It has no influence on the exposure or working of the camera.

At the same time the film speed should be set on the film speed disc of the exposure meter (see exposure meter, p. 70).

## Holding

It is obvious that the camera should be held as steady as possible, as the slightest shake, even if not seen in the negative, will become visible in an enlargement. Always stand with your legs apart.

For horizontal photographs grip the camera with your right hand with the index finger on the release button on the camera top and the thumb against the camera back. Thumb and index finger of the left hand move the focusing mount while the camera body rests on the middle finger and ball of the left hand for additional support. Keep the elbows pressed against the body. Either the right or the left eye may be used for the finder.

For vertical photographs turn the camera through 90 degrees so that in the same basic holding position as for horizontal photographs—your right hand grips the top.

You can vary this standard hold, of course, to suit your own convenience. By some experimenting, you will find the grip which suits you best, and enables you to hold the camera really steady.

To release the shutter, press the release button with the ball of the finger. Use finger pressure only, and keep the hand and its grip on the camera steady. The actual pressing down will have to be done slowly and smoothly. The slower

**16** the exposure time, the smoother must be the release.

## LOADING

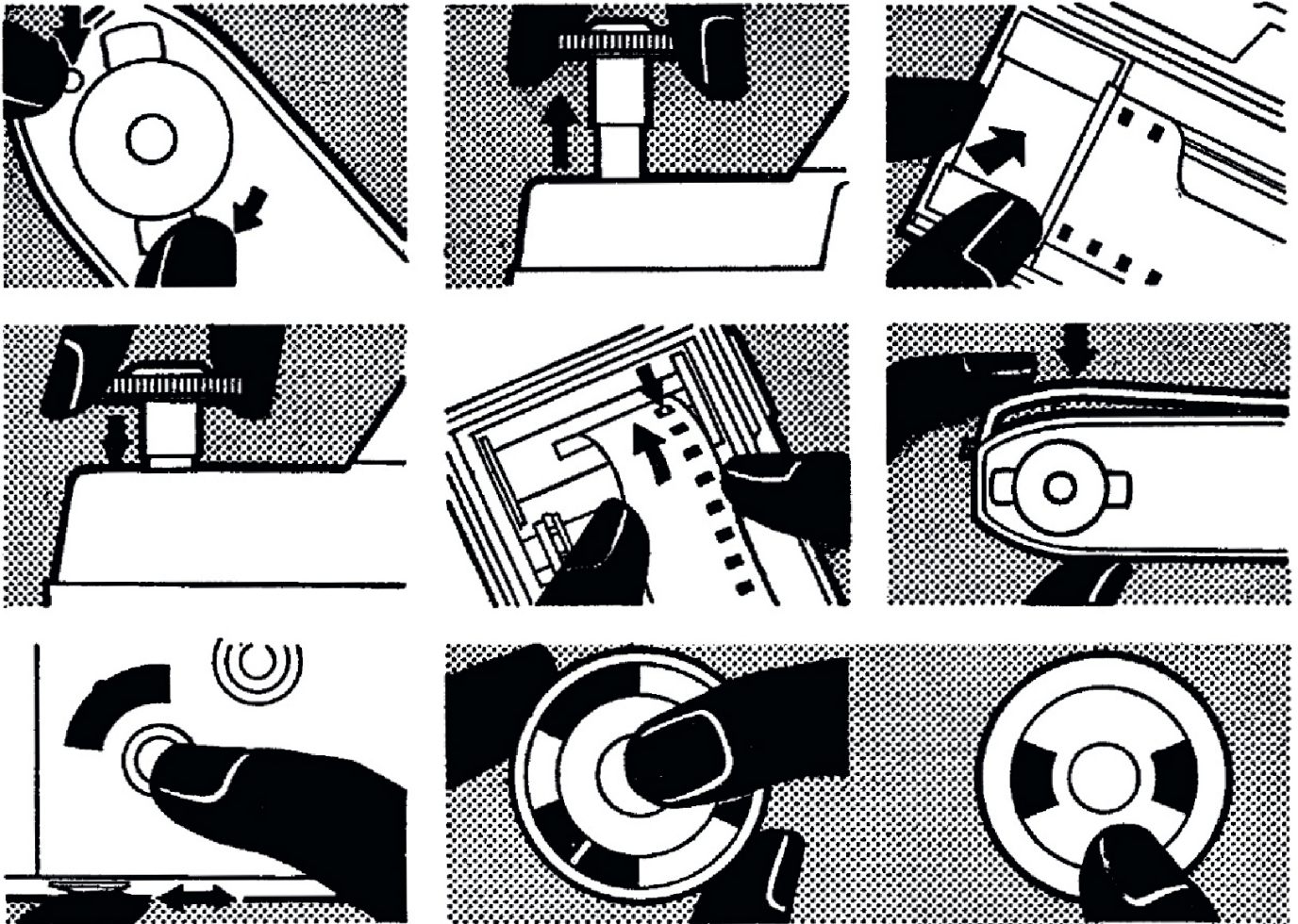

*Top left:* Open camera back.

*Top centre:* Pull out rewind knob to its second stop.

*Top right:* Insert cassette with film into empty chamber.

*Centre left:* Push back rewind knob into normal position.

*Centre:* Thread film into slit of take-up spool.

*Centre right:* Close camera back.

*Bottom left:* Set exposure counter according to the number of frames of film in use.

*Bottom centre:* Set film indicator on rewind knob according to film in use.

*Bottom right:* Set film speed on exposure meter.

For slow exposures in the hand it is advisable to rest the elbows, or at least to lean the body, against some support in order to avoid shake. In this way  $1/15$ ,  $\frac{1}{8}$  and  $\frac{1}{4}$  and even  $\frac{1}{2}$  sec. can be risked without incurring camera shake.

Such a support is also desirable for faster exposures, as several movements take place inside the camera after pressing the release button. A slightly unsteady hold may thus easily lead to blurred pictures. For the same reason, keep the camera steady for a moment after pressing the button; do not jerk it away from the eye straight away, as the shutter opens about  $1/50$  sec. after pressing.

The use of a tripod is necessary when taking time exposures and it is also recommended for speeds from  $1/15$  to  $1$  sec. For upright photographs from the tripod use a ball and socket head to allow changing from the horizontal to the vertical position.

## Carrying

To be ready for quick action it is best to carry the camera on a short strap round the neck so that it lies on your chest. Lifting it up to the eye is then a matter of a split second.

For convenience and protection the Retina Reflex should always be carried in its ever-ready case. This case is designed to hold the camera ready for use. A camera retaining screw fixed to the case screws into the tripod bush to hold the camera securely in the case even when open. The elastic clip inside the top of the case is intended to hold the incident light diffuser of the exposure meter.

## Shooting

Practise the following operations, first with an empty camera, until they become practically automatic.

1. **Wind film transport lever.**
2. **Determine light value.**
3. **Select aperture/shutter speed combination.**
4. **Focus and determine picture.**
5. **Release.**

- 18 1. Swing film transport lever out as far as it will go ( $180^\circ$ ). It will only spring back into its original position if it has been wound fully.

## HOLDING



For horizontal shots, hold the camera firmly with the right hand, with the index finger resting lightly on the shutter release. The thumb and index finger of the left hand are then free for focusing.



Press the elbows close to the body,



always stand with your legs well apart,

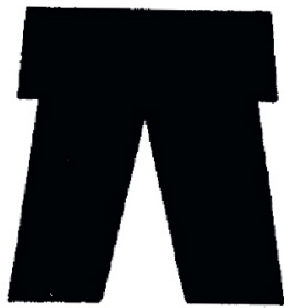

and hold quite still while you release.

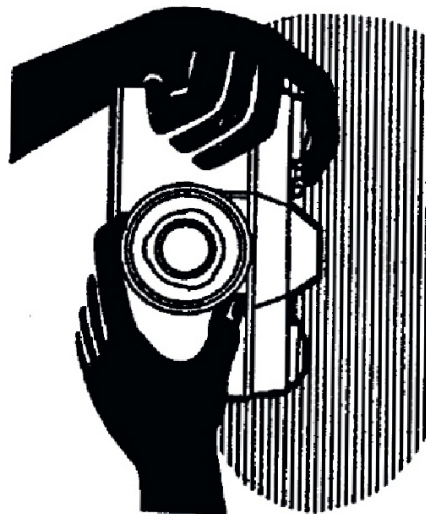

For upright shots, turn the camera through 90° so that it is supported from below with the left hand, the thumb and index finger resting on the focusing ring. The right hand holds the camera steady from above with the index finger on the release button.

*Below:* With the Retina Reflex it is specially important to keep the camera really steady during the exposure and for a fraction of a second after pressing the release button. Wherever possible, support your body against something solid, such as a tree or wall or prop up your arms against your knees or a fence, particularly with the slower speeds. Use a cable release for time exposures from a tripod.

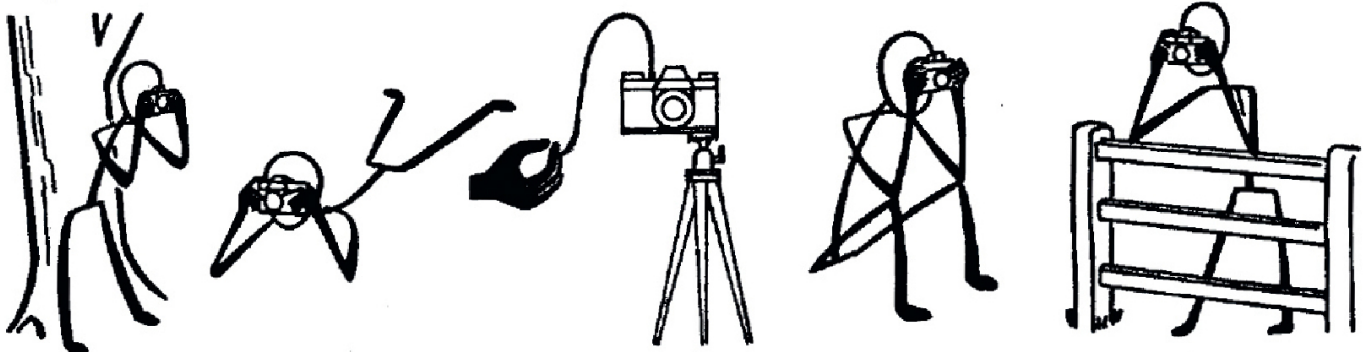

2. *Retina Reflex*. Determine the light value (which gives you the correct exposure) with the built-in exposure meter as instructed on p. 71. Set this light value on shutter rim as explained on p. 10.  
*Retina Reflex S*. Set the exposure by taking an exposure meter reading (p. 70)
3. Turn front rim on shutter until the required aperture/exposure time combination points to the elongated diamond mark on top of the shutter mount (see p. 10).
4. Focus and determine the picture field through finder (p. 12).
5. Release by gently pressing the release button.

## Unloading

After all exposures have been made, the camera has to be unloaded. The exposure counter window should, at this stage, indicate 0. The film transport lever locks after you have made the last exposure on your film.

1. **Depress reversing button.**
  2. **Rewind film.**
  3. **Open camera back.**
  4. **Remove cassette.**
  5. **Close camera back or reload with new film.**
1. Depress the reversing button in the base of the camera situated in the curve of the film transport lever.
  2. Pull out rewind knob to its first stop and turn it in the direction of the engraved arrow (clockwise) until the reversing button ceases to rotate. This button carries a black dot near its edge for easy observation of movement.
  3. Open camera back as instructed on p. 15, No. 1.
  4. Pull out rewind knob to its second stop and take out cassette.
  5. Close camera back as instructed on p. 15, No. 6, or reload as instructed on p. 15.

## Cutting off Exposed Lengths

If a film which is only partly exposed has to be processed, it can be cut off in the darkroom or in complete darkness. After the last exposure the film transport should be wound on once more, the camera back opened in the darkroom, and the film cut about  $\frac{1}{2}$  in. away from the cartridge. The exposed part on the take-up spool is removed by winding the film from the take-up spool and wrapping it up in three pieces of black opaque paper. The remaining film in the

## SHOOTING

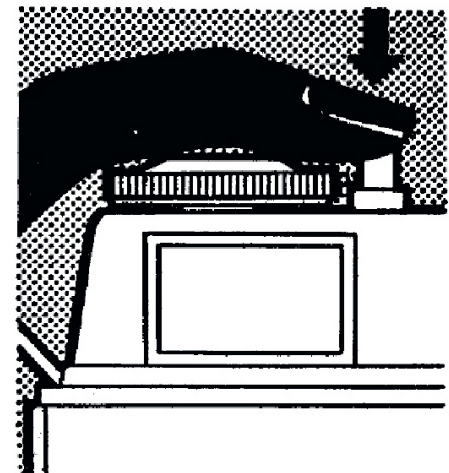
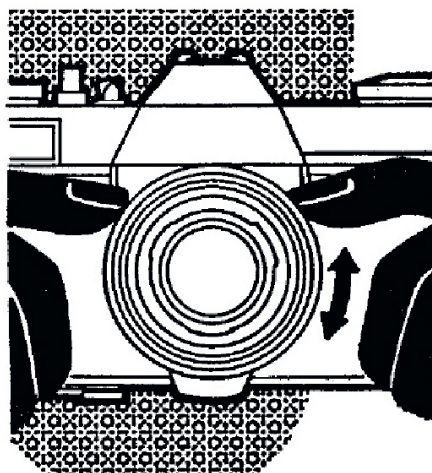
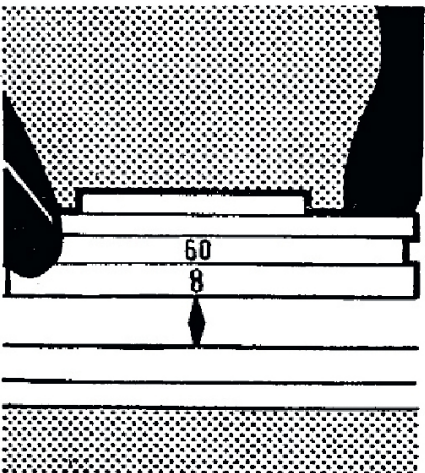
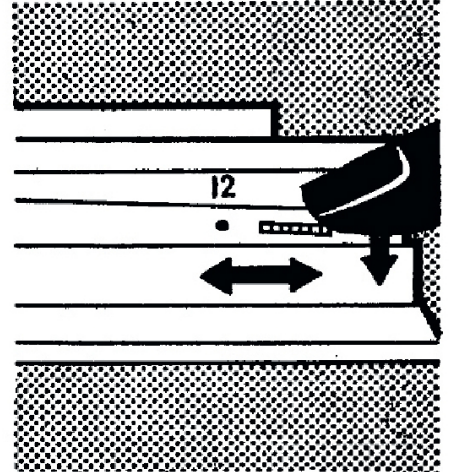
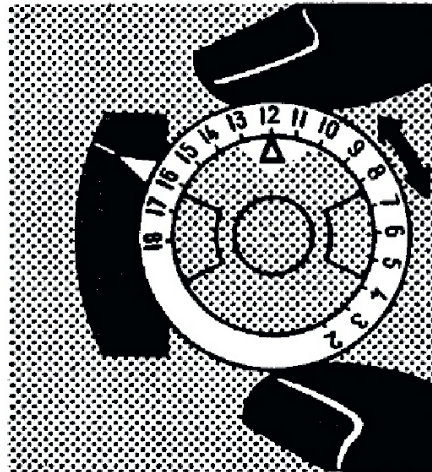
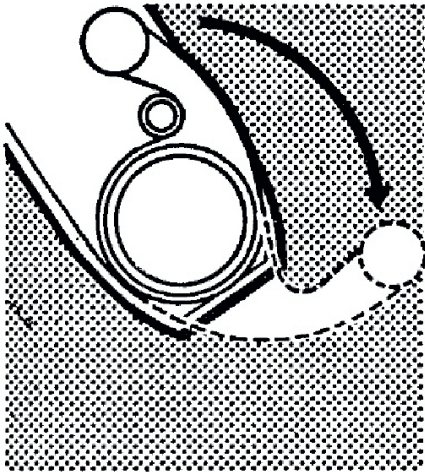

*Top left:* Wind film by means of rapid winding lever.

*Top centre:* Determine light value with built-in exposure meter (for Retina Reflex S, see page 70).

*Top right:* Set light value on scale.

*Bottom left:* Select aperture-shutter speed combination by rotating shutter rim.

*Bottom centre:* Focus and determine picture.

*Bottom right:* Release by gently pressing release button.

the camera closed. If the re-inserting has been done in the darkroom no further blind exposure is necessary; if the film has been re-inserted in daylight, two blind exposures should be made and the exposure counter should be advanced by two. Note that short lengths of some makes of colour reversal film will not be accepted for processing.

### Changing Partly Exposed Films

To replace a partly exposed film by another one—for instance, if you want to take a few colour photographs in between some black-and-white shots—proceed as follows.

- 1. Check number of still unexposed frames on film counter.**
- 2. Rewind film.**
- 3. Unload.**

When reloading:

- 4. Load film in camera.**
  - 5. Close back.**
  - 6. Set exposure counter to starting point.**
  - 7. Depress film release while winding film on.**
2. When rewinding the film be careful to wind only until you feel some resistance. In the ordinary way this resistance would have to be overcome in order to pull the film end from the take-up spool. If the film is to be reloaded again, you must not pull the whole film into the cassette, otherwise the film end will have to be extricated by opening the cassette in the darkroom for subsequent re-insertion into the camera.
  3. Take the re-wound film out of the camera. For reference, note the number of exposures still left on the film and write this number on the label of the cassette. Then put it into a container or wrap it up. Now you can load the camera with any other type of film.
  4. To use the partly-exposed film again, it has to be re-loaded into the camera.
  7. Do not press the shutter release button and wind on (this would open the shutter and expose the already exposed frames). Press film release and wind the rapid wind lever until the required picture number (the next unexposed frame) appears in the exposure counter.

### The Film Release of the Retina Reflex

22 Apart from its application in changing partly exposed films (see above), the film release helps in rectifying any

## UNLOADING

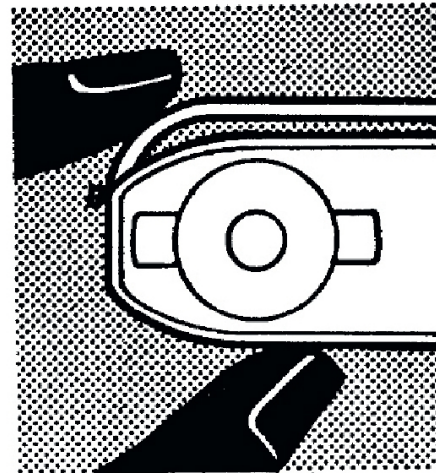
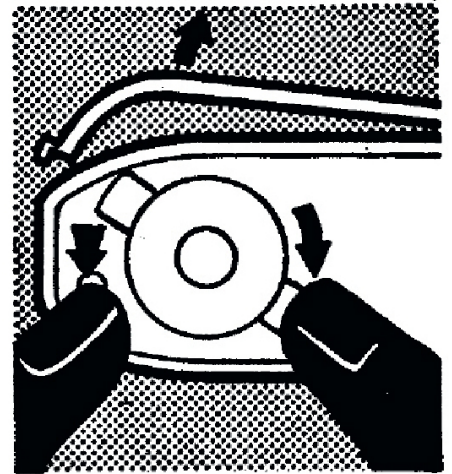
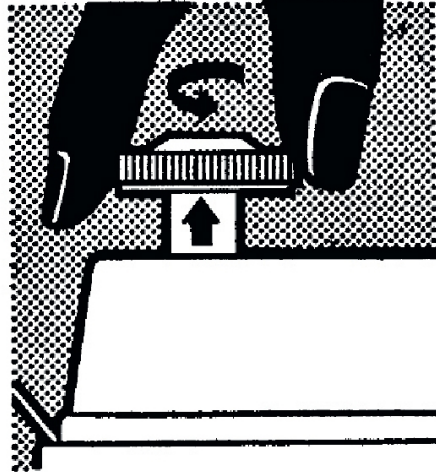
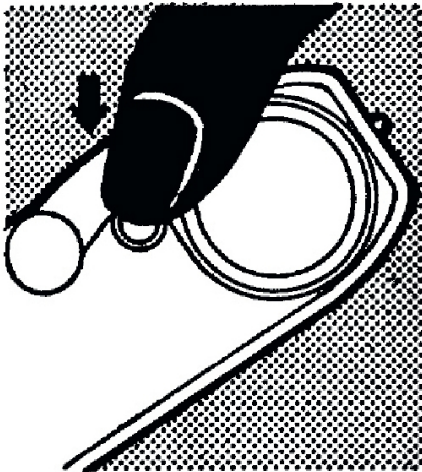

*Top left:* Press down rewind button on base of camera.

*Top centre:* Pull out rewind knob to its first stop and rewind film.

*Top right:* Open camera back.

*Bottom left:* Pull out rewind knob to its second stop and take out cassette.

*Bottom right:* Close camera back or reload with new film.

jamming which may lock the mechanism of the rapid winder. Simply depress this button to clear the winder, without losing a frame or risking a double exposure. If pressure on the film release does not release the winder, this automatically indicates that the end of the film has been reached.

Similarly, if you did not set the exposure counter when loading you may reach No. 1 on the exposure counter before the end of the film is reached. At No. 1 the rapid wind lever automatically locks. By pressing the film release lever you can re-set the exposure counter, which at the same time will free the winding lever. Should the winding lever stick in a between position, press the film release button on the base to make it spring back.

## Double Exposures

The double-exposure lock of the Retina Reflex prevents accidental double exposures. To make a deliberate double exposure for special purposes, press the reversing button after the first exposure, and keep it depressed while tensioning the shutter with the rapid winding lever. The film then remains in position for a second exposure on the same frame. Note that operating the rapid winder after the second exposure also advances the film counter to indicate one frame more than the number exposed.

## RETINA REFLEX FILMS

The film for the Retina Reflex camera is the standard perforated cine film of 35 mm. width, as used in the majority of other 35 mm. cameras. It may be obtained as:

**DAYLIGHT CASSETTES.** These are the simplest form of Retina Reflex film packings. The ready cut and trimmed films for 36 exposures are supplied in cassettes (also called "cartridges" or "patrones"), which can be loaded in daylight into the camera (see p. 15). Colour films are generally supplied in either 20 exposure lengths or 36.

**DARKROOM REFILLS** are lengths cut and trimmed for 36 exposures and will have to be filled in the darkroom into a cassette (see p. 29).

**DAYLIGHT REFILLS** are cut and trimmed for 36 exposures which are wound on to a centre spool (as used in the cassette) and covered with a black paper leader strip to allow the loading of a cassette in daylight (see p. 29).

**BULK FILM** of 18 ft. to 200 ft. length, in which case a suitable length will have to be cut off to be loaded into a cassette in the darkroom (see p. 29).

### Safelight

The loading of cassettes with darkroom refills or from bulk film has to be carried out in the darkroom.

In the case of *panchromatic films* (see p. 30) only the dark green safelight may be used, but it is always safer to work in complete darkness. This is not difficult. It is, however, advisable to practise filling with a dummy film first in daylight before starting the darkroom work.

In the case of *positive film* (see p. 30) amber light will do.

### Handling, Winding and Trimming the Film

When handling the actual film, particular care must be taken not to touch its emulsion (matt) side. It should only be handled and wound on to the centre spool of the cartridge by holding the film by either side of its edge, preferably between thumb and index finger.

At the same time, it is of no less importance that the place in which the loading is done should be perfectly dry, clean and free from dust. Only a clean, spotless negative will produce the desired result!

When using bulk film for loading cassettes, the edge of the work-bench can be marked with notches or drawing-pins to indicate various distances, let us say for 12, 24, 36 exposures of film. This considerably simplifies the measuring of film lengths in the darkroom.

The trimming of the film-ends is performed most simply with the aid of a 35 mm. film trimming template. At the beginning of the roll of film make the wedge-shaped cut for the centre spool and measure off the required length of film. At the end of this make the curved cut for the taking-up spool. The curved cut must *not* go through a perforation hole. When doing this job with the trimming template it leaves at the same time the correct cut for the taking-up spool on the remaining film on the roll, so that about 4 in. of film are saved on every strip. When trimming film without a template it is sufficient to start the curved cut between the tenth and eleventh bottom hole from the end—facing the emulsion side of the film—as it is not essential to have the full standard cut when working with the Retina Reflex and a 2 in. (5 cm.) cut will serve the same purpose quite well.

The ready-cut film is now wound on to the centre spool of the cassette, as described on p. 29. One must make sure, while winding on, to hold the film only by its edges.

This task can be simplified by the use of a special hand winder, a milled metal rod with a slit on one end to fit into the cross-pin fitting of the spool. A mechanical winder may be obtained to serve the same purpose. It can be attached to the edge of the work-bench. 12 full turns with this will wind sufficient film for about 12 exposures; 18 turns = 19 exposures; 32 turns = full length for 36 exposures.

When winding the film on and off, care must be taken that no great pressure is put on the film, and that the film-ends are not squeezed when drawing through the hand.

## TRIMMING AND WINDING FILM

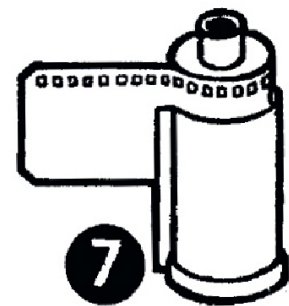
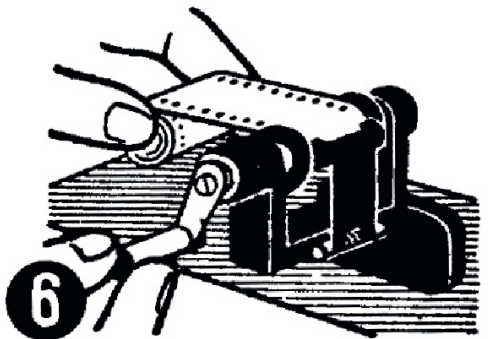
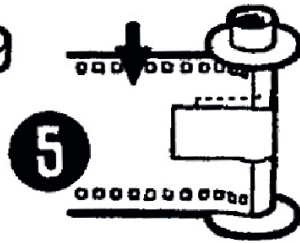
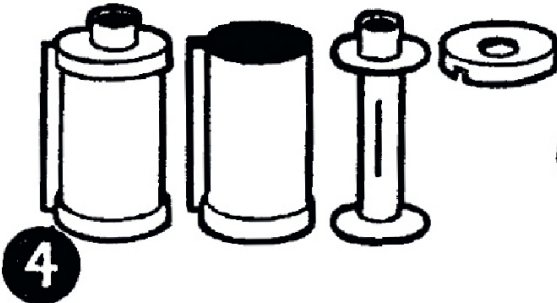
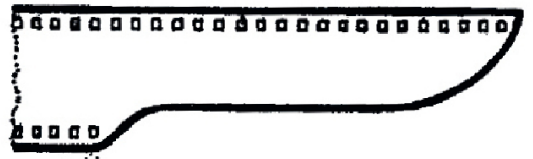
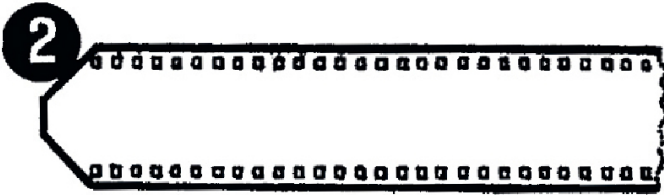
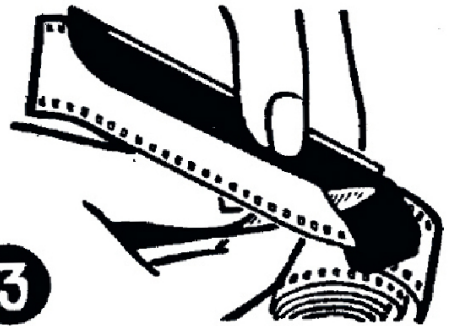
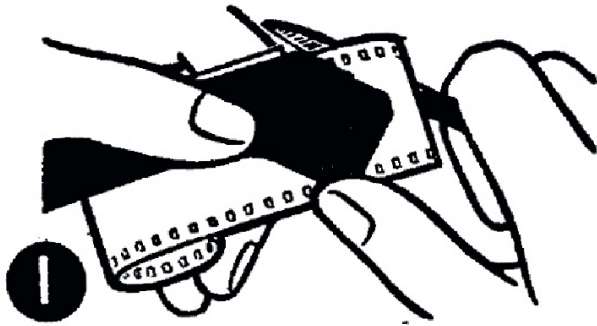

**1:** The correct trimming of the wedge shaped end (which is attached to the centre spool of the cassette) with standard trimming template. **2:** the appearance of the trimmed film, left wedge, right curved cut. **3:** Trimming of curved cut with standard template. **4:** The cassette, its outer shell, centre spool and cap. **5:** How to fix the film to the centre spool. **6:** Winding film on to the centre spool with a mechanical winder. **7:** Assembling the cassette. **8:** Loading film into camera.

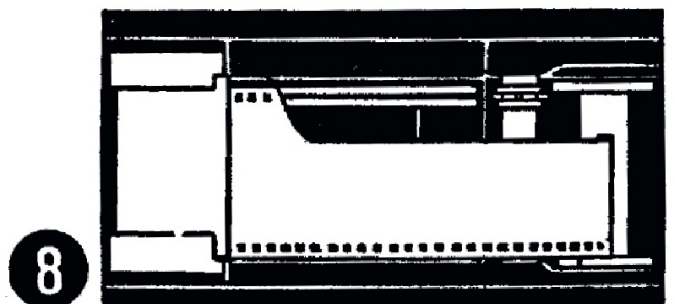

Failure to take the first precaution may result in fogging, while neglect of the latter precaution may give rise to peculiar kinds of exposure effects known as "lightning flashes". These are due to static electrical discharges, and appear as dark, zigzag lines running from the edge of the film towards the centre of the picture.

#### LENGTH OF FILM REQUIRED FOR ANY NUMBER OF EXPOSURES

Number of Exposures	Length of Film Required		Number of Exposures	Length of Film Required		Number of Exposures	Length of Film Required	
	in.	cm.		in.	cm.		in.	cm.
1	11 $\frac{3}{4}$	30	14	31 $\frac{3}{4}$	80	27	51	130
2	13 $\frac{1}{2}$	34	15	33	84	28	52 $\frac{1}{2}$	133
3	15	38	16	34 $\frac{1}{2}$	88	29	54	137
4	16 $\frac{1}{4}$	41	17	36 $\frac{1}{4}$	92	30	55 $\frac{1}{2}$	141
5	17 $\frac{3}{4}$	45	18	37 $\frac{3}{4}$	96	31	57	145
6	19 $\frac{1}{4}$	49	19	39 $\frac{1}{4}$	100	32	58 $\frac{1}{2}$	148
7	20 $\frac{3}{4}$	53	20	40 $\frac{1}{2}$	103	33	60	152
8	22	56	21	42	107	34	61 $\frac{1}{2}$	156
9	23 $\frac{3}{4}$	60	22	43 $\frac{3}{4}$	111	35	63	160
10	25 $\frac{1}{4}$	64	23	45	114	36	64 $\frac{1}{2}$	164
11	26 $\frac{3}{4}$	68	24	46 $\frac{1}{2}$	118	37	66	167
12	28 $\frac{1}{2}$	72	25	48	122	38	67 $\frac{1}{2}$	171
13	30	76	26	49 $\frac{1}{2}$	126	Including trimming		

#### Loading Retina Reflex Cassettes

The Retina Reflex cassette consists of a flanged centre spool which is in a one-piece shell; the film leaves the shell by a light trapped slot. The centre spool can be removed from the shell by lifting either top or bottom of the cartridge according to the construction of the particular make of cassette. Most of the cassettes of the daylight loading films are intended by their makers to be used once only. However, they can be re-loaded quite a few times—if handled

## **Loading Cassettes with Darkroom Film**

- 1. Work in the darkroom in appropriate safelight.**
  - 2. Prepare film.**
  - 3. Open cassette.**
  - 4. Fix film on centre spool.**
  - 5. Wind film on centre spool.**
  - 6. Insert centre spool into shell; the first 2 in. of film must extend from the light trap.**
  - 7. Close cassette.**
- 2.** In the case of bulk film prepare the length to be used as described on p. 25. When using darkroom refill remove its wrappings. It is useful to fold the first  $\frac{1}{2}$  in. (1 cm.) of the beginning of the film slightly backwards. It prevents its slipping away.
  - 4.** If the centre spool is fitted with a film catch, thread the tapered end of the film into it. In cases where the centre spool is fitted with a spring, thread the end under it and fold it sharply back. If the centre spool is without any suitable fitting to hold the film, it has been proved best to wind a  $1\frac{1}{2}$  in. (4 cm.) piece of adhesive cellulose tape round the centre spool, so that on either side about  $\frac{1}{2}$  in. tape is used to secure the film (see p. 27).
  - 5.** Wind film on centre spool moderately tightly. Care must be taken to see that the fingers do not come into contact with the emulsion, only the back and sides of the film being touched.
  - 7.** When using some makes of cassettes (e.g., *Agfa, Ansco, Ilford*), it is essential to fix top or bottom cover to the shell preferably with a length of adhesive cellulose tape.

## **Loading Cassettes with Daylight Refills**

- 1. No darkroom is necessary.**
  - 2. Remove wrapping and label of refill.**
  - 3. Open cassette.**
  - 4. Introduce refill into shell of cassette; the first 2 in. of paper-leader has to extend from light trap.**
  - 5. Close cassette.**
  - 6. Pull out paper-leader and 2 in. of film.**
  - 7. Cut off paper-leader.**
- 4.** The original centre spool of the cassette is not needed and may be kept separately.
  - 7.** When using some makes of cassette (e.g., *Agfa, Ansco, Ilford*), it is essential to fix top or bottom cover to the shell, preferably with a length of adhesive cellulose tape.

## The Choice of Black-and-White Material

There is no such thing as a "best" film for any or every kind of picture. Each type of film has certain characteristics.

**COLOUR SENSITIVITY.** Practically all 35 mm. films are sensitive to all colours. They are what is known as *panchromatic*. Some types of high sensitivity are especially sensitive to red. They are thus very suitable for photography with artificial light which is richer in red than daylight.

**INFRA-RED FILM.** Infra-red film is a negative material which, unlike panchromatic films, is made sensitive to infra-red rays, which are not visible to the human eye. Special applications of this material: photography by "invisible" light, long-distance shots, fog or mist penetration, scientific copying and research work.

**ORDINARY FILM.** For copying black-and-white objects (books, ledgers, etc.) a *positive film* can be recommended. Besides its qualities of fine grain and high brilliancy, it possesses the further advantage that it can be handled in an amber darkroom light.

**SPEED.** The sensitivity of film materials to light in general is expressed by various scales, such as *BS, ASA, Scheiner, DIN, Weston*, and so on. Scientists and manufacturers all agree that none of the methods employed to determine the speed of films is entirely satisfactory, and continue giving preference to one or the other of them. Although speed is a very obvious asset, it is also a quality which must be paid for by possible disadvantages of the material in some other respect. To call the fastest film the best would be as foolish as to select a racing car for daily motoring in a busy town.

**GRAIN.** The picture in the emulsion is formed by silver grains. To the naked eye they form a compact, dark mass, but under the magnifying glass or microscope the separate clumps of grains are visible. Obviously, if the grain of our film is coarse, it will soon become visible by moderate enlarging; and the finer the structure of grain, the more enlarging will it allow without showing any unpleasant granular effect in the print. As a rule, it can be said that the faster the film, the coarser the grain and *vice-versa*. The grain can, to a certain extent, be influenced by development (fine-grain development), correct exposure, paper, etc.

## FILM SPEED, CONTRAST, GRAIN, RESOLVING POWER

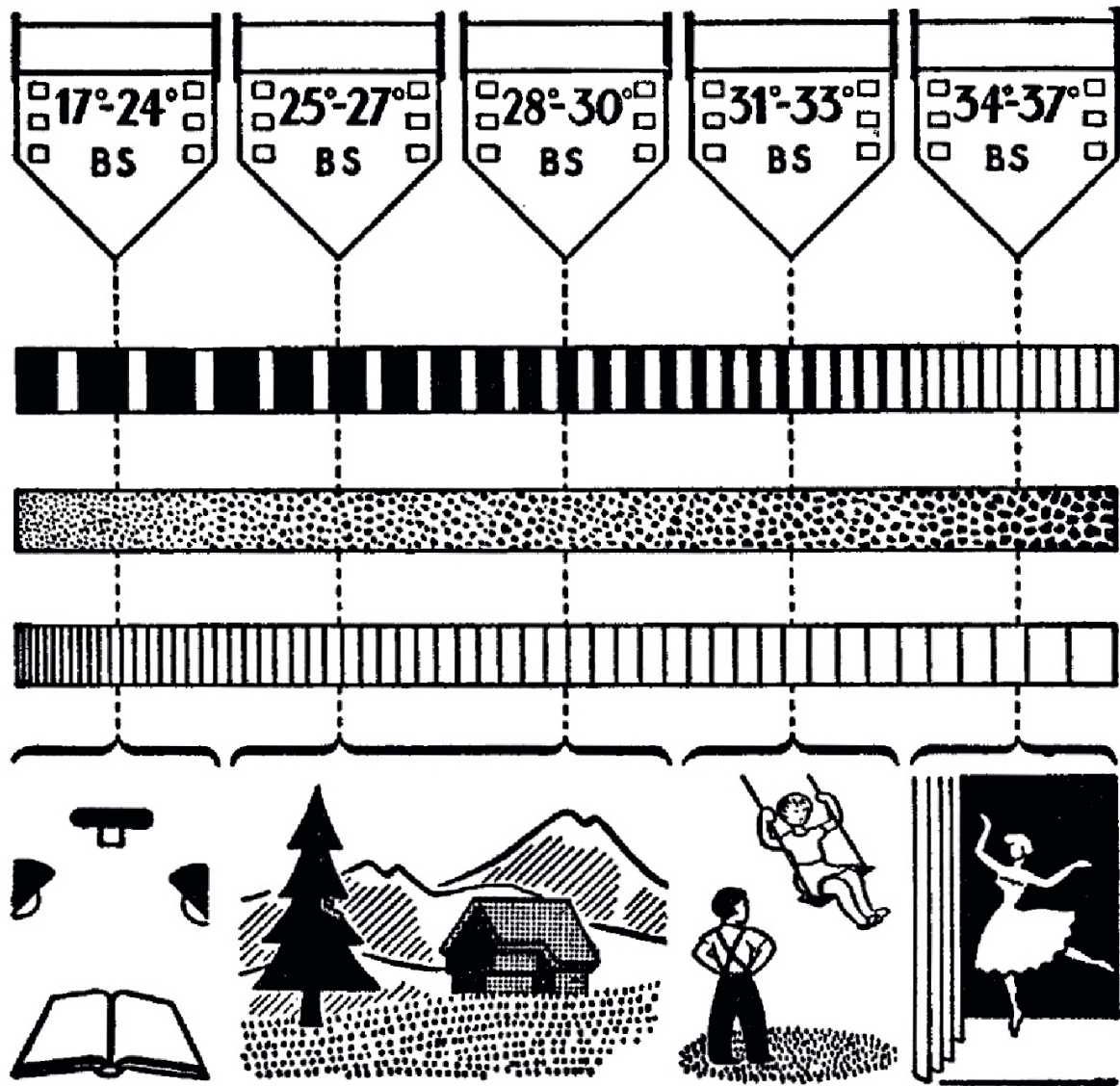

Generally speaking, low speed goes with greatest contrast, finest grain and highest resolving power and vice versa. The film speed in the *top* row points to the corresponding contrast, grain and resolving power. The contrast row shows (from left to right) how high contrast becomes medium and low as speed grows. The grain row shows (from left to right) how fine grain turns into medium grain with growing speed and finally the resolving power row shows the decrease of resolving power (number of lines) with increase of film speed. The *bottom* row indicates the type of subjects for which films of the various speeds are best.

While a scientifically correct conversion of one speed rating system to another cannot be made owing to their different principles, the following list gives some guidance as to their practical relationship.

**CONVERSION TABLE OF DIFFERENT SPEED DEGREES**

BS & ASA. Index (Logar.)	BS & ASA. Index (Arithm.)	European Scheiner	Weston Speed (pre-1957)	G.E. Speed	DIN
13°	1.5	14°	1.2	2	3°
16°	3	17°	2.5	4	6°
19°	6	20°	5	8	9°
22°	12	23°	10	16	12°
25°	25	26°	20	32	15°
28°	50	29°	40	64	18°
31°	100	32°	80	125	21°
34°	200	35°	160	250	24°
37°	400	38°	320	500	27°

In this table each value represents twice as fast a film speed as the one immediately above it. In some systems this doubling of film speed means increasing the speed number by 3 each time (BS Log. Index, Scheiner, DIN), while in others the film speed itself is directly proportional to the speed number, and therefore inversely proportional to the exposure required (BS Arith. Index, Weston, G.E.).

*Slow films* of less than about 24° BS can be usefully employed for scientific photography, copying and architectural details. Their main advantage is in their extremely fine grain, making special development unnecessary. Their disadvantage is in their inability to cope with live subjects in other than exceptionally favourable lighting conditions.

*Medium films* of 26–30° BS are the right material for the beginner, and can be well employed for any of the average subjects. Their advantages are: reasonably fine grain without the use of too complicated methods of development, correct tone rendering, good resolving power. Disadvantage: further loss of speed if fine grain development has to be employed for the sake of big enlargements.

*Fast films* of 31° BS and over for high-speed sport shots, interiors, stage pictures and night photography. Advantages: increased sensitivity for red (artificial light), use of smaller apertures (increased depth of focus). Disadvantages: graininess which, however, can be improved by special methods of developing, at some cost of speed; also somewhat distorted tones (red too light).



*THE FAST LENS of the Retina Reflex covers subjects even in unfavourable conditions. The oil lamp sheds just enough light to illuminate the faces close to it. This type of shot requires a high-speed film as well as a large lens aperture and a certain amount of stage direction.—H. SCHNEIDER.* **33**



*OUTDOOR SHOTS* are as easy as with any camera, but the large reflex screen shows the exact view very clearly. You see every fleeting expression of a child engrossed in playing with his pet (above), and can check the precise arrangement of groups (opposite) and other set-ups.

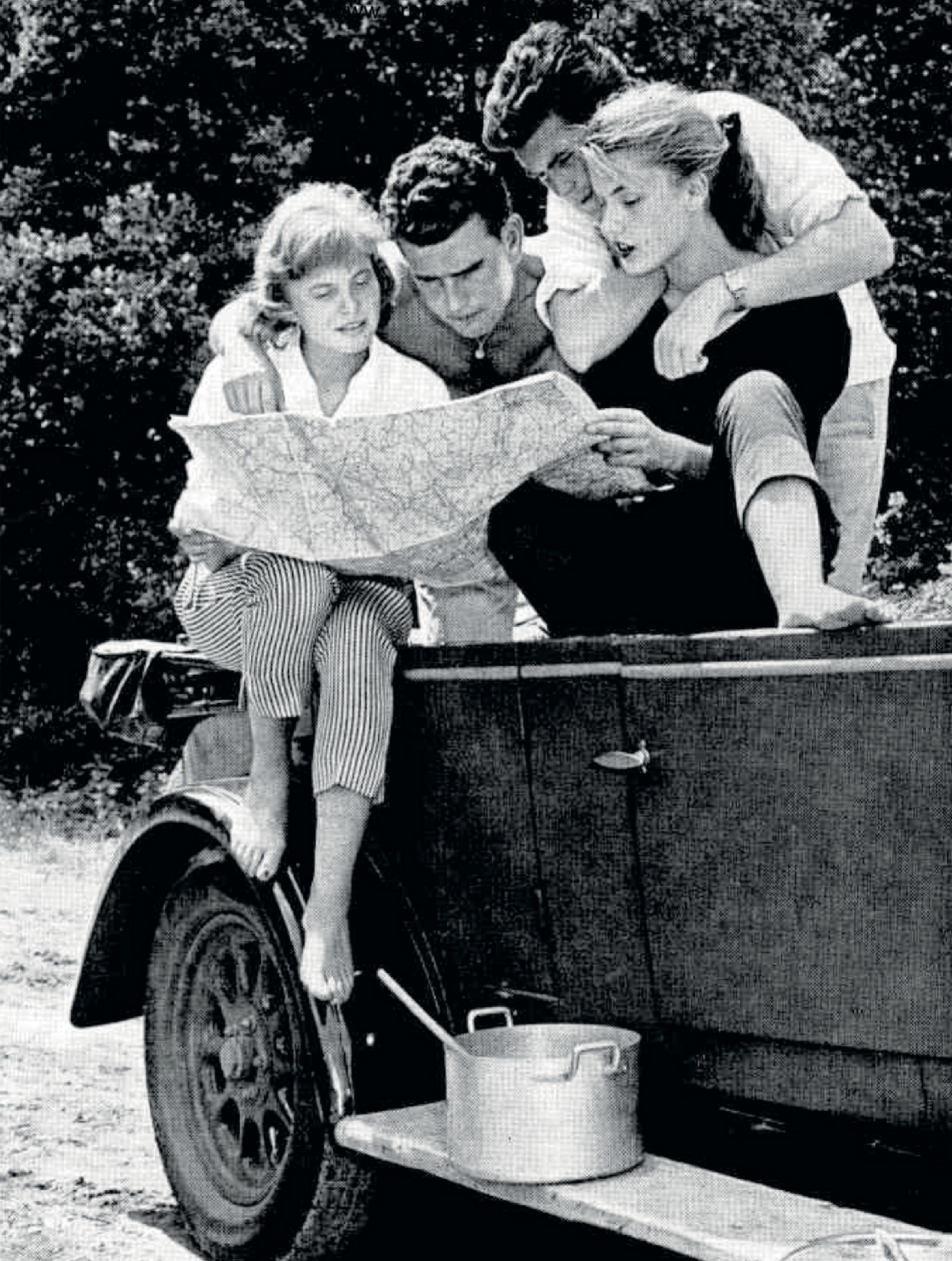

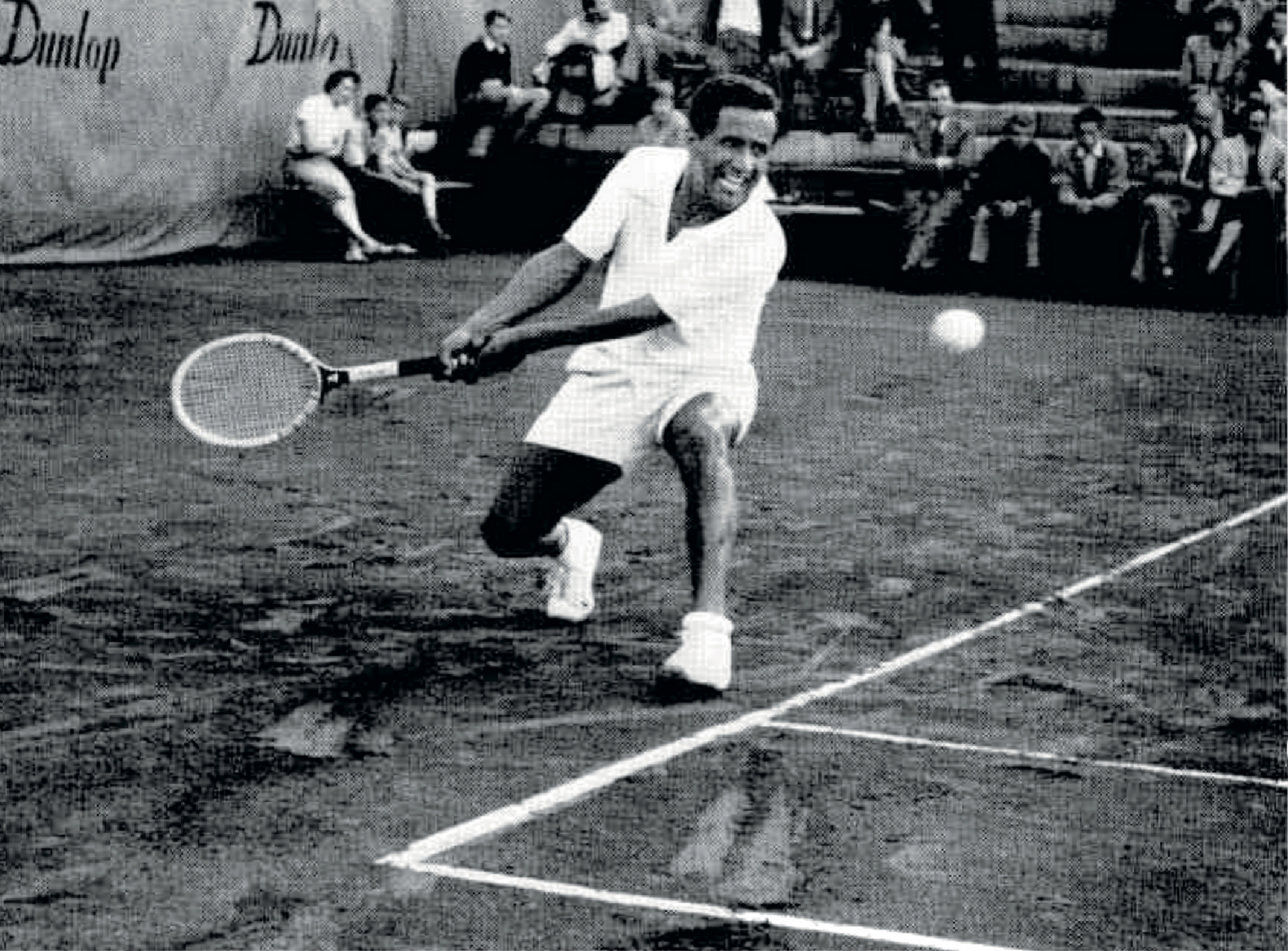

*ACTION (above) demands fast shutter speeds to freeze dramatic moments. Pre-set the distance and exposure and try to shoot a fraction of a second before the right moment. —HERBERT SCHNEIDER.*

*FOR VIEWS (opposite) the reflex screen finder is ideal when you compose the picture. The image is almost in full natural size, yet brilliant and clear at eye-level.—DR. PAULY.*

*INDOORS, synchronized flash is the best means of lighting (pages 38 and 39). It captures live family scenes at home, or action in bowling alleys, ice rinks, restaurants and other places where the available light is inadequate.*

*—HERMANN WEISHAUP and ALFONS RUDOLPH.*





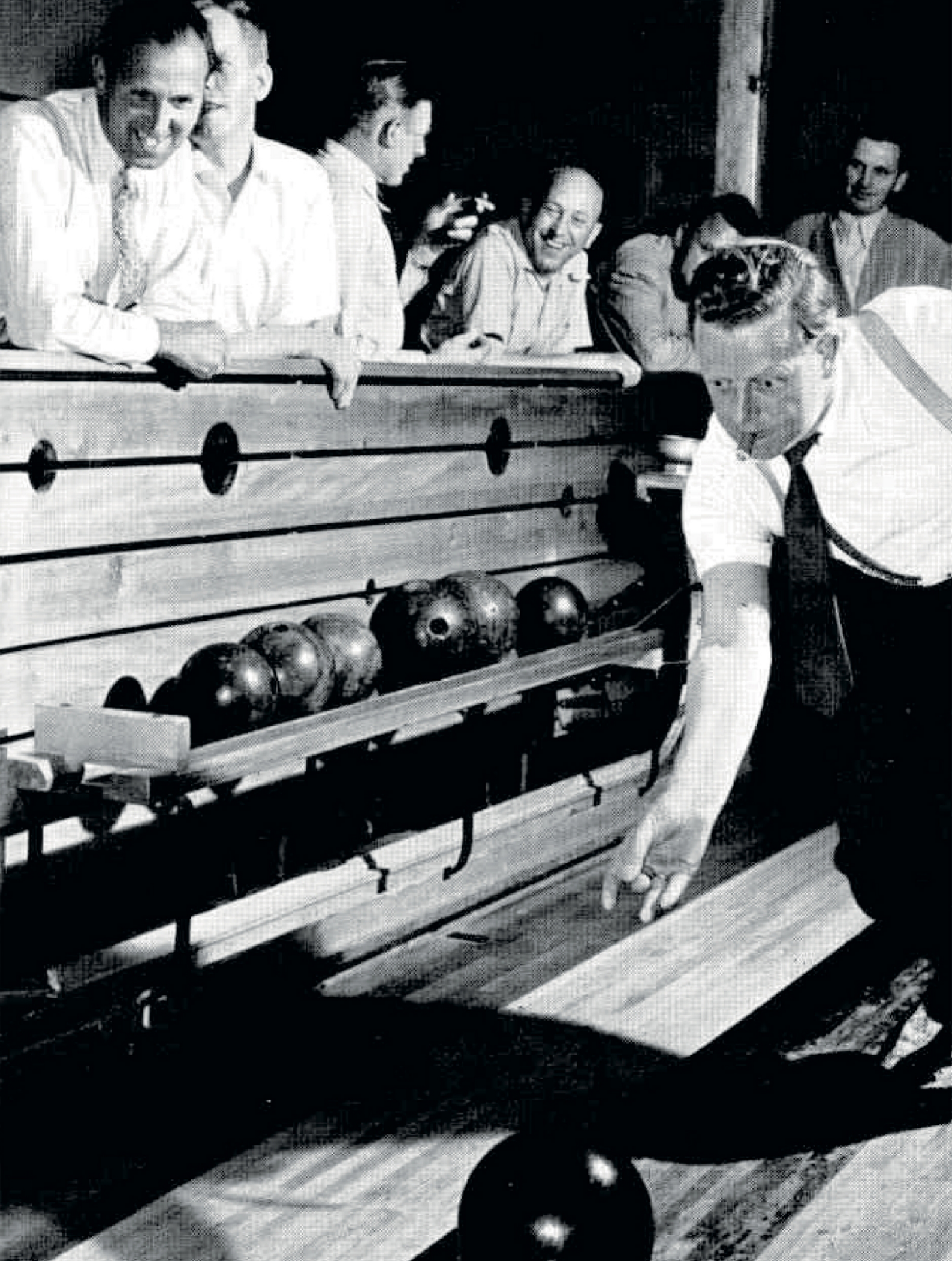





*SPEED can be even more effectively rendered if you do not freeze it altogether (above). For this picture the photographer swung the camera round to follow the cyclists while exposing.—ALEXANDER HUBRICH.*

*WINTER WEATHER is still photogenic (opposite). Use a slow shutter speed for falling snow, but keep the camera well protected against the weather. A lens hood will shield the lens itself against snowflakes falling on it.*

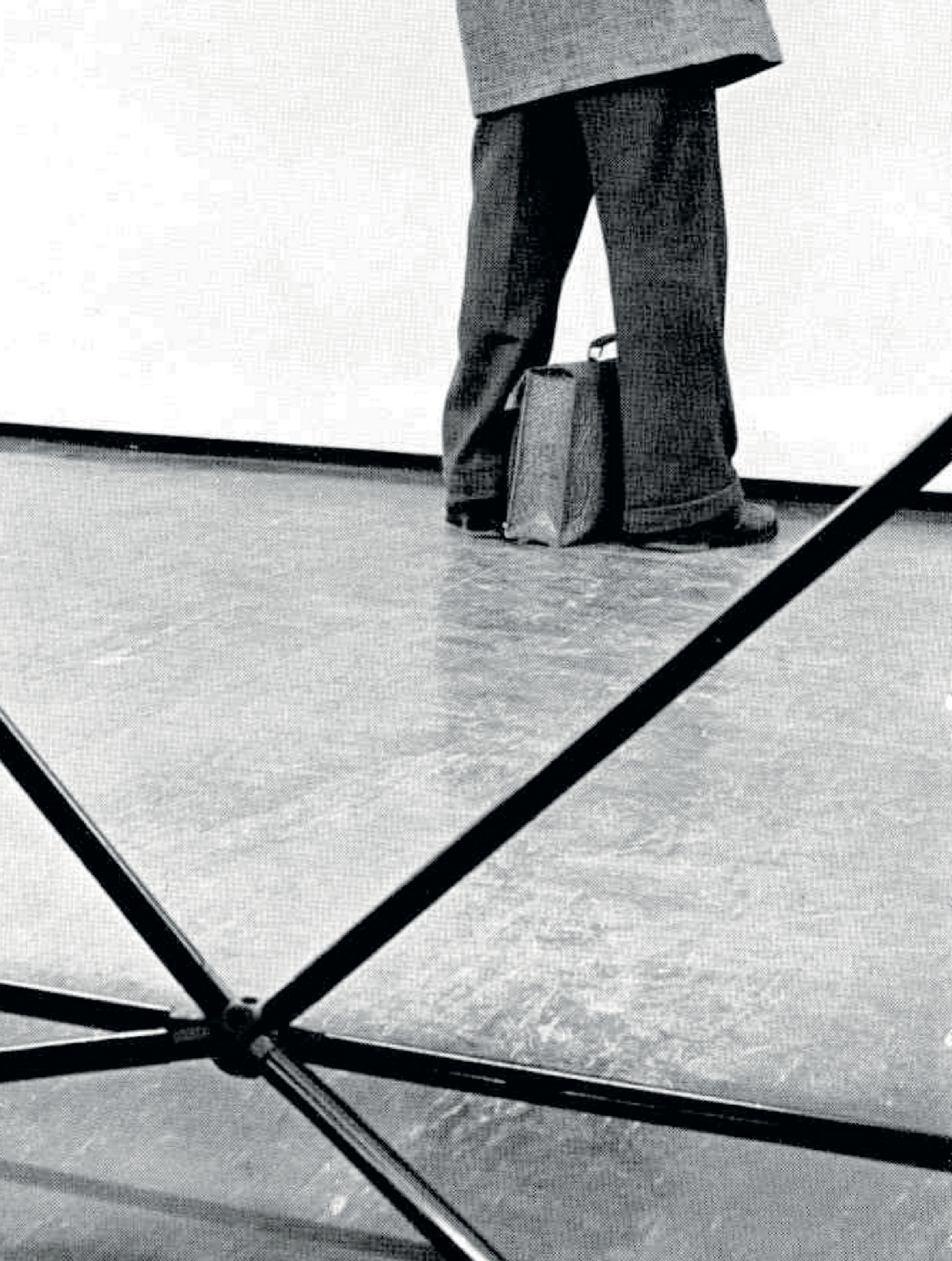



*PATTERNS* (above and opposite) make the picture, even when the elements are unusual in appearance or viewpoint. Correct choice of the latter is important, with a constant check of the effect in the viewfinder.—HANS GELBING.

*CLOSE-RANGE* photography (pages 44, 45 and 46) only requires supplementary lenses; the focusing screen and optical rangefinder show the precise point of maximum sharpness, as well as the exact field covered. This is an extensive and interesting field and takes in nature subjects as well as advertising and table-top photography.—HANS GELBING and OSKAR KREISEL.





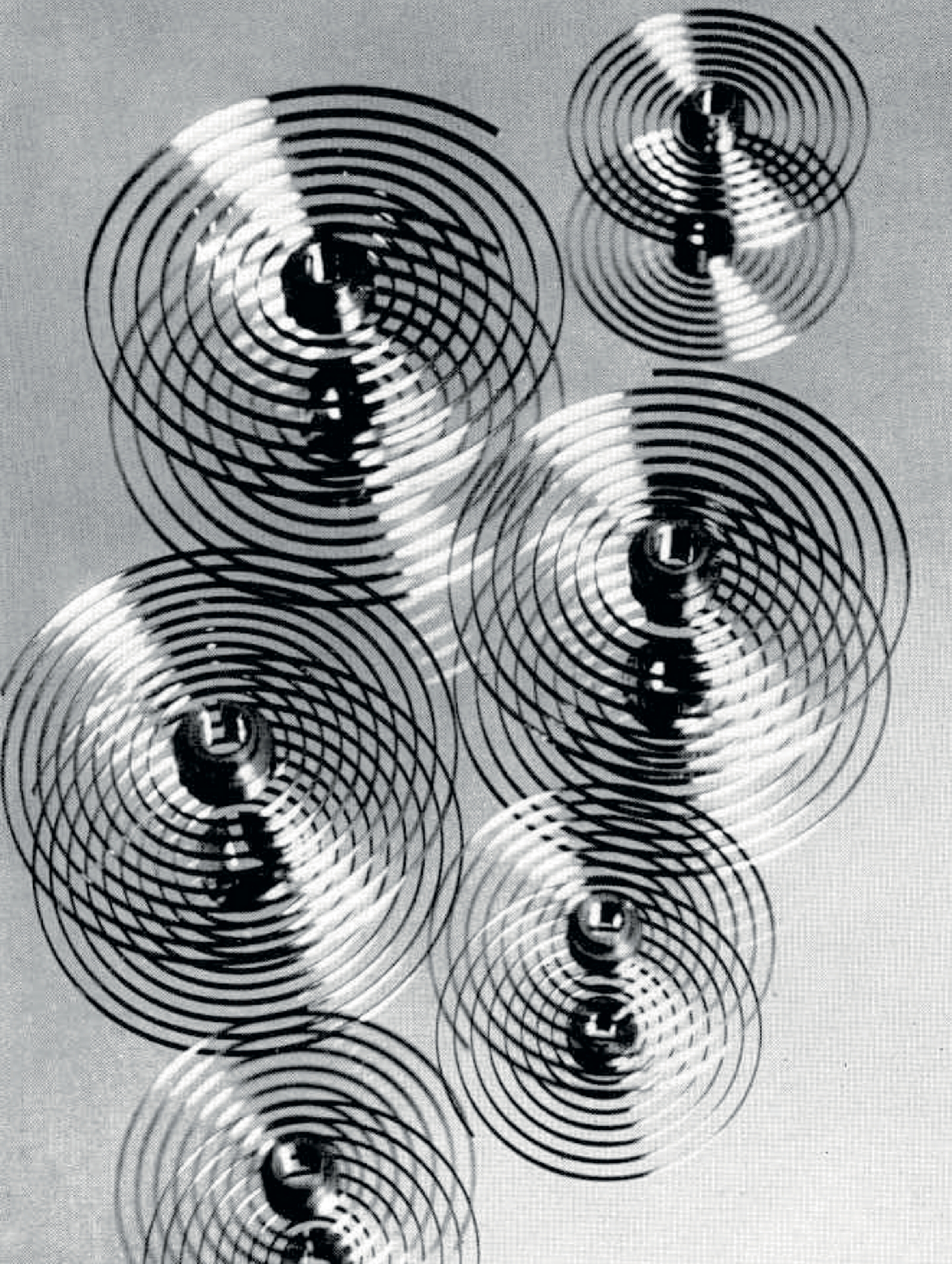



THE INTERCHANGEABLE LENS units of the Retina Reflex can be used to control not only image scale but also perspective. With the telephoto lens (above) a shot taken well back from the subject emphasizes the background. With the standard lens (above right) the foreground becomes more prominent, while a picture taken at close range with the wide-angle lens (right) accentuates the foreground at the expense of the rest of the scene.—HANS GELBING.





Our negative material has a number of additional properties which help towards good results. There is, e.g. a special "protective coating", a hardened gelatine layer on top of the actual sensitive layer which protects against scratches. The base has been coloured, as a rule grey, in order to avoid reflection of the light coming through the emulsion on to the film-back and thus causing halation.

### CHARACTERISTICS OF SOME 35 mm. FILMS

Make	Type	Speed in		Grain	Gradation
		°BS	ASA		
<i>Agfa</i>					
Isopan FF ...	P.	23°	16	uf.	v.
Isopan F ...	P.	27°	40	ef.	n.
Isopan ISS ...	Pr.	31°	100	fg.	n/s.
Isopan Ultra ...	Pr.	33°	160	mg.	n/s.
Isopan Record ...	Pr.	39°	640	mg.	n.
<i>AnSCO</i>					
Supreme ...	P.	28°	50	fg.	n.
U.S. Pan ...	P.	31°	100	mg.	n.
Super Hypan ...	P.	34°	200	mg.	n.
<i>Ferrania</i>					
P.3 ...	P.	27°	40	ef.	n.
S.2 ...	Pr.	31°	100	mg.	n/s.
<i>Gevaert</i>					
Gevapan 27 ...	P.	26°	32	ef.	n.
Gevapan 30 ...	P.	29°	64	fg.	n.
Gevapan 33 ...	P.	32°	125	mg.	n/s.
Gevapan 36 ...	Pr.	35°	250	mg.	n.
<i>Ilford</i>					
Pan F ...	P.	25°	25	ef.	v.
F.P.3 ...	P.	29°	64	ef.	n.
H.P.3 ...	Pr.	34°	200	mg.	n/s.
H.P.S. ...	Pr.	37°	400	mg.	n/s.
<i>Kodak</i>					
Panatomic X ...	P.	25°	25	ef.	n.
Plus X ...	P.	29°	64	fg.	n.
Tri X ...	P.	34°	200	mg.	n/s.
<i>Perutz</i>					
Pergrano 14... ...	P.	23°	16	uf.	v.
Perpantic 18 ...	Pr.	28°	50	fg.	n.
Peromnia 21 ...	Pr.	31°	100	mg.	n.
Peromnia 25 ...	Pr.	35°	250	mg.	n.
<i>Schleussner</i>					
Adox KB 14 ...	P.	24°	20	uf.	v.
Adox KB 17 ...	P.	27°	40	ef.	n.
Adox KB 21 ...	Pr.	31°	100	mg.	n/s.
Adox KB 25 ...	Pr.	35°	250	mg.	n/s.

TYPE: P. = panchromatic; Pr. = panchromatic with increased red sensitivity.  
 GRAIN. uf. = ultra fine grain; ef. = extra fine grain; fg. = fine grain; mg. = medium grain.  
 GRADATION. n. = normal; n/s. = normal tending to soft; s. = soft; v. = vigorous.

**GRADATION.** Each film has an ability of its own to reproduce various degrees of brightness on its emulsion. If the ability of a film is confined to only a small number of black-and-white tones, we speak of a "high contrast" or *hard* negative material. If it is able to reproduce many delicate shades of grey between black and white, it is known as a "low contrast", or *soft* film. Generally speaking, low speed films of fine grain possess a higher contrast.

**LATITUDE.** Latitude is the ability of the film to yield usable negatives, even with a certain amount of under- or (more often) over-exposure. Films praised for particularly wide latitude may facilitate exposure, but are likely to have less *resolving power*, causing loss of definition.

## Colour Film

Beside the films mentioned which reproduce the world around us in black and white, colour films enable us to photograph in natural colours.

**THE PRINCIPLE.** There are two types of colour film on the market.

The first, negative colour film, produces negatives in colour. These resemble ordinary negatives—the dark parts of the subject are light and vice versa—and in addition the colours are reversed. Thus blues are yellow or brownish, reds are blue-green, and greens are reddish.

These colour negatives are then printed on a similar kind of material to give colour prints or colour enlargements. We can also use these negatives to obtain black-and-white prints in the normal way.

The second type of colour film known as reversal colour film, produces positive colour transparencies on the film exposed in the camera. These transparencies can then be viewed by transmitted light or projected through a projector.

Both kinds of colour film are available in two types, **50** balanced for daylight or for certain artificial light sources.

## 35 mm. COLOUR FILMS ON THE MARKET

Film	Type	Speed in		Processing
		BS	ASA	
Adox Color 17NC Neg.	Universal	27°	40	L
Adox Color C15 Rev.	Daylight	25°	25	L
Agfacolor CN14 Neg.	Universal	24°	20	U
Agfacolor Neg.	Universal (Type CN 17)	27°	40	U
Agfacolor Rev.	Daylight (Type CT 18)	28°	50	M
Agfacolor Rev.	Artificial light (Type CK)	26°	32	M
Ansochrome Rev.	Daylight	26°	32	U
Ansochrome Rev.	Artificial light	26°	32	U
Super Ansochrome Rev.	Daylight	31°	100	U
Super Ansochrome Rev.	Artificial light	31°	100	U
Ektachrome Rev.	Daylight	26°	32	U
Ektachrome Rev.	Flash	25°	25	U
Ferraniacolor Rev.	Daylight	24°	20	U
Ferraniacolor Rev.	Artificial light	24°	20	U
Gevacolor Neg.	Daylight (Type N5)	25°	25	L
Gevacolor Rev.	Daylight (Type R5)	27°	40	M
Ilford Colour Rev.	Daylight (Type D)	21°	10	M
Ilford Colour Rev.	Flash (Type F)	21°	10	M
Kodachrome Rev.	Daylight (Type D)	21°	10	M
Kodachrome Rev.	Artificial light (Type A)	23°	16	M
Kodachrome Rev.	Flash (Type F)	23°	16	M
Kodacolor Neg.	Universal	26°	32	U
Pakolor Neg. Super 40	Daylight	27°	40	U
Perutz Color C18 Rev.	Daylight	28°	50	M

**PROCESSING:** M=films can be processed by the maker only; L=films can be processed by an approved laboratory through a photographic dealer; U=films can be processed by the user by means of a special processing kit.

**EXPOSING COLOUR FILM.** The exposure latitude of colour film is small. It is therefore important to ascertain the exposure time accurately with a reliable photoelectric meter. Underexposed and overexposed films not only produce dense or weak results but also the colour values are distorted. Overexposure produces pale, diluted colours, underexposure gives hard, deep colours.

Avoid great contrast such as deep shadows. For photographs in daylight use daylight type film. Use artificial light film when taking pictures indoors by the light of electric lamps or Photofloods. Daylight film may be used in artificial light and vice versa with the special conversion filter recommended by the makers.

Some of these conversion filters (Wratten) are supplied in **51**

the original filter range for the Retina Reflex. There is also a Kodachrome haze filter for daylight type film which is used to reduce the blue haze in distant landscape shots. This filter needs no exposure increase. It is also useful for colour photography with electronic flash, producing a somewhat warmer result.

For taking colour pictures by flashlight, use daylight type film with blue-tinted bulbs or electronic flash, or alternatively flash type film with clear flash bulbs. The *Focal Colour Chart* gives full data.

**DISPLAYING THE COLOUR PICTURE.** The colour transparency can be viewed in a variety of transparency viewers. The simplest consist of a magnifying glass set in a frame into which the picture can be inserted. If the viewer is held against a lighted background, the picture appears enlarged and well illuminated. More elaborate viewers have an artificial light source of their own.

The most satisfactory way is to project the transparency in a projector which will throw a large picture on a screen. Finally, colour enlargements can be made from transparencies. These cannot show the full tonal range and brilliancy of the projected picture, but are generally acceptable particularly if the transparency does not show undue contrast range, is correctly exposed and is sharp.

The colour negative can be printed or enlarged directly on colour paper to produce a colour print of any size. Alternatively, the colour negatives can be printed on positive transparency film to produce colour transparencies for viewing or projection in exactly the same way as explained above.

## RETINA REFLEX LENSES

*The Retina Reflex* (but not Reflex S) has interchangeable lens front components. As an alternative to the standard 5 cm. lens, an 8 cm.  $f 4$  telephoto lens front component can be used. For wide-angle photography a 3.5 cm.  $f 4$  lens front component, or alternatively the 3.5 cm.  $f 5.6$  lens front component, can be used (this latter is primarily designed for the Retina IIC and IIIC cameras).

If your Retina Reflex is fitted with the 5 cm. Xenon C as the standard lens, you can only use the Longar-Xenon C 8 cm.  $f 4$  lens and the Curtar-Xenon 3.5 cm.  $f 4$  or  $f 5.6$ . Retina Reflex cameras fitted with the 5 cm. Heligon C can take only the Heligon C 8 cm.  $f 4$  and the Heligon C 3.5 cm.  $f 4$  or  $f 5.6$  lenses respectively.

*The Retina Reflex S* lens system is removed as a whole and can be replaced by any of the following tele lenses: 8.5 cm. Retina Tele-Arton and Retina Rotelar  $f 4$  and 13.5 cm. Retina Tele-Xenar and Retina Rotelar  $f 4$ . Wide-angle lenses available are the 2.8 cm. Retina Curtagon  $f 4$  and 3.5 cm. Retina Curtagon  $f 2.8$  and Retina Eurygon  $f 4$ .

The effect of the wide-angle lens is to increase the field covered, showing more than the standard lens does. It is suitable for interiors, architectural and panorama photography, and also for candid and action shots where the greater depth of field (see p. 62) is an advantage, or where there is not enough time for accurate focusing. The angle of view with the standard 5 cm. lens is  $47^\circ$ , the angles with the 2.8 cm. and 3.5 cm. lenses are  $76^\circ$  and  $64^\circ$  respectively.

The telephoto lens is particularly suited for subjects which are difficult to approach closely, such as animals, children, sports, architectural details, and the like. The angle of view of the 8 cm. lens is  $30^\circ$ , 8.5 cm. lens  $28^\circ$ , and the 13.5 cm. lens  $19^\circ$ .

### Changing the Lenses

To remove the interchangeable front component of the standard Retina Reflex lens, press the safety catch inwards **53**

(towards the lens) and turn the front part of the lens in an anti-clockwise direction as far as it will go, that is, until its red dot is opposite the red dot on the black outer rim of the lens mount. The lens can now be lifted out. For easy removal and safe storage of the standard lens, the special container available for it should be used.

To insert an alternative lens unit into the camera, place it in position over the mount so that the red dot on the lens lies opposite to the red dot on the shutter rim. When the lens is seated, turn it firmly in a clockwise direction as far as it will go to engage the bayonet lock. A slight click is usually audible.

To remove the lens of the Reflex S depress the lens lock underneath the lens barrel and at the same time turn the lens anti-clockwise as far as it will go, and lift out.

To insert a lens, place it with its red dot on the lens mount against a similar red dot on the bayonet ring of the shutter. Now turn the lens clockwise until the catch engages.

### Focusing with the Interchangeable Lenses

After changing the standard lens against the wide-angle or telephoto lens units, the image is focused on either the ground glass screen or with the optically coupled split image rangefinder in the same way as with the standard lens (see page 12). At the same time, the reflex screen shows the exact field of view of the particular lens used. There is no parallax error nor are any supplementary viewfinders required.

**DEPTH OF FIELD.** To ascertain the depth of field (see page 62) obtained with either telephoto or wide-angle lens, focus the Retina Reflex with the rangefinder or reflex screen. The depth of field indicator pointers of the Retina Reflex S directly show the extent of the depth of field (see p. 59) on the Retina Reflex. Read off the distance setting on the distance scale opposite the elongated diamond mark. Then set this figure on the *black* scale of the telephoto or wide-angle unit against the red triangular mark (▲). The extent of depth of field can now be read off to the right and left

## THE INTERCHANGEABLE LENSES

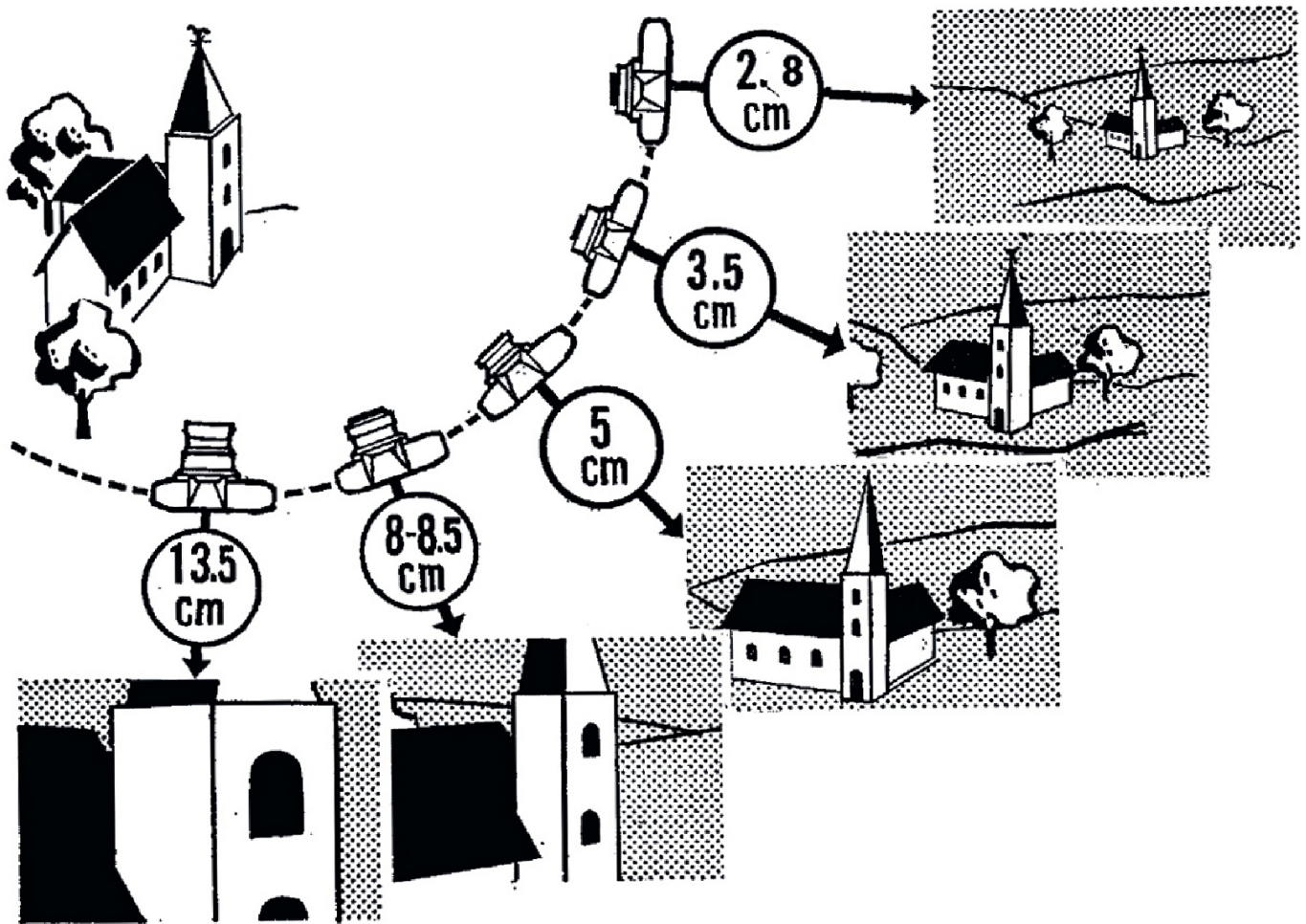

Above: The interchangeable lenses greatly increase the versatility of the Retina Reflex. The wide-angle lens (*top*) covers a larger angle of view as compared with the standard lens (*centre*). The telephoto lens, on the other hand, includes a much narrower angle and shows distant subjects larger (*bottom*).

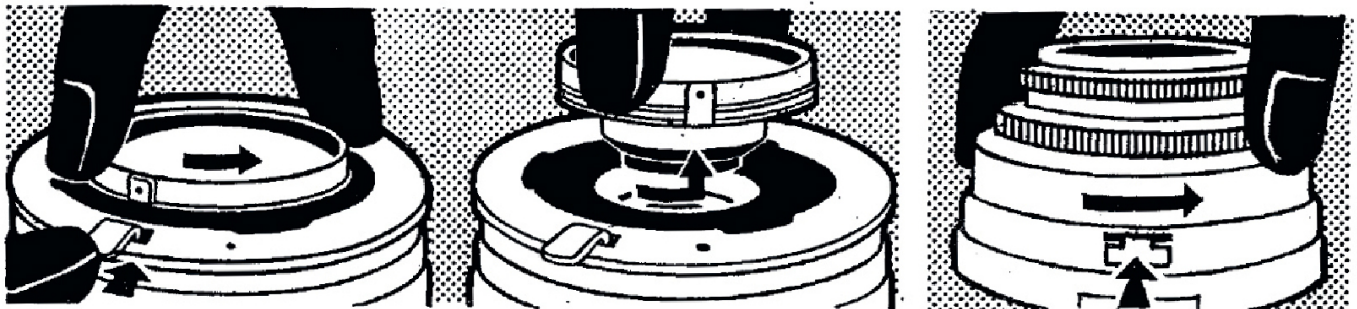

Above: To change lenses of the Retina Reflex, remove the front component by pressing the safety catch inwards and turn it in an anti-clockwise direction (*left*). It can then be lifted out (*centre*). With the Retina Reflex S, press the catch below the barrel, and turn the milled lens mounting ring anti-clockwise (*right*).

of this triangular mark on the white scale of the lens (see also below).

**ZONE FOCUSING WITH C LENSES** (not Reflex S). The zone focus setting on the wide-angle lens is marked by a black circle near the 10 ft. position on the lens scale, marked "35 mm." in red. Set this circle to the red triangular mark (▲) on the adjacent scale. The triangle lined up with the circle (●) points to the black distance scale of this lens to 20 ft.; thus indicating that the distance on the camera focusing scale should be set to 20 ft. to obtain a depth of field from  $5\frac{1}{2}$  ft. to infinity at  $f 11$ .

The telephoto unit carries two zone focus settings each marked by a black circle, one near the 50 ft. figure (far zone setting) and the other one near the 15 ft. figure (near zone setting) on the distance scale marked "80 mm." in red.

For far zone focus setting, line up the circle near the 50 ft. mark with the red triangular mark on the adjacent scale and they will point to 20 ft. on the black scale. Set camera distance to 20 ft., and at  $f 11$  a depth of field from about 25 ft. to infinity is obtained.

For near focusing use the black circle near the 15 ft. mark and align with the red triangle. When properly aligned they will point to 6 ft. on the black distance scale. At an aperture of  $f 11$  a depth of field from approximately  $11\frac{1}{2}$  to 20 ft. is obtained.

*The scale rings* on both the telephoto and wide-angle units are solely *calculating* rings for depth of field and zone focus setting. They have no other function; in particular, they are not used for distance setting.

### Close-ups with the Telephoto C Lens

The telephoto lens covers distances between  $6\frac{1}{2}$  ft. and infinity. Closer distances, between  $3\frac{1}{2}$  and  $6\frac{1}{2}$  ft., can be taken with the aid of the T1/60 close-up lens. This will be found particularly useful for close-up portraits to avoid distortion. The T1/60 lens is also suitable for the 13.5 cm. long-focus lens of the Retina Reflex S.

**56** The correct distance setting as well as the accurate field

## FOCUSING ZONES WITH INTERCHANGEABLE LENSES

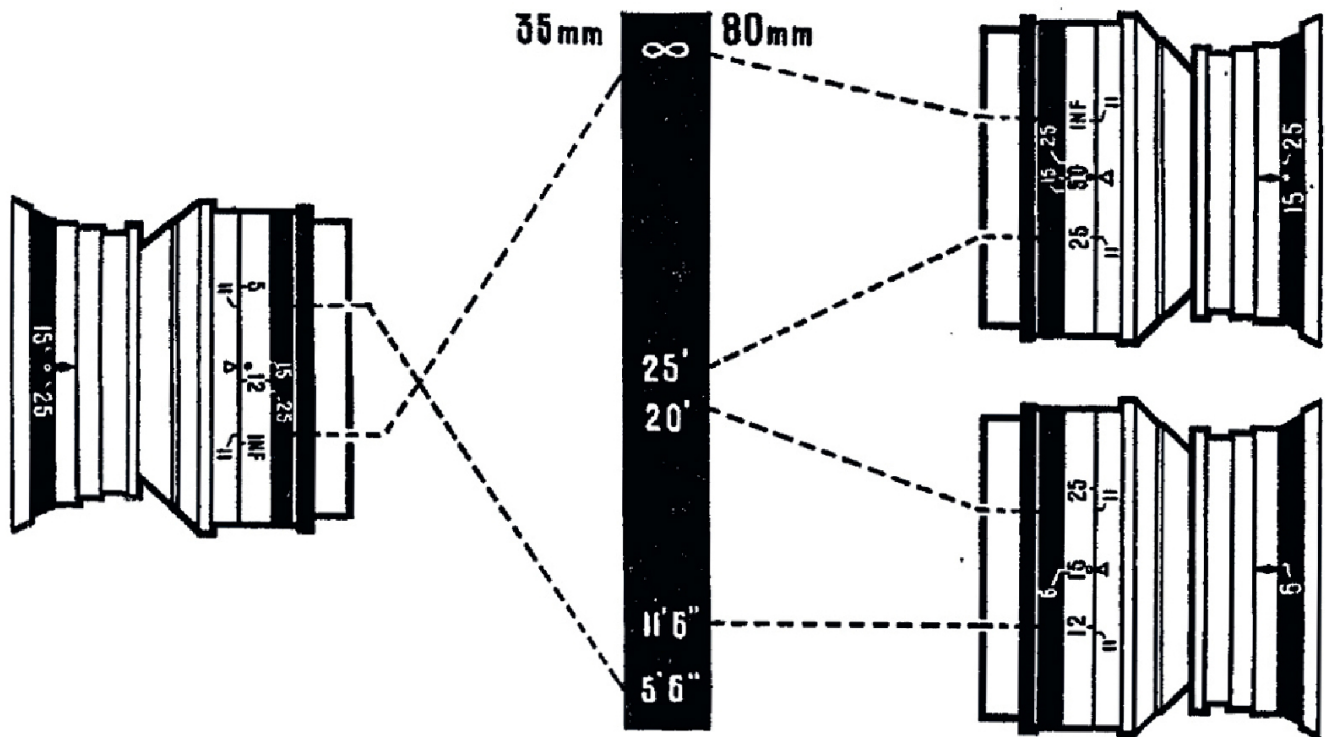

Above: With the wide-angle lens (left) the zone focus setting is marked by a small black circle. Set this circle to the red triangular index mark. The black scale now indicates about 20 ft. Set the distance scale to 20 ft. and the aperture to  $f/11$ . This yields a sharp zone of focus from about 5½ ft. to infinity. The telephoto lens (right) has two small black circles. For near focusing, set the circle near figure 15 to the red triangle. The black scale then indicates 6 ft. Set the distance scale to 6 ft. and the aperture to  $f/11$ , and the zone of sharp focus extends from about 11½ ft. to 20 ft. For far focusing, set the black circle near figure 50 to the red triangle. The black scale will then indicate 20 ft. Set this figure on the distance scale and the aperture to  $f/11$ , and the zone of sharp focus extends from 25 ft. to infinity.

covered is—as in all other cases—observed through the reflex finder. To determine the depth of field available, focus on the subject in the normal way. Read off the distance setting and set the equivalent figure on the *black* scale of the lens to the red triangular mark. Now read off the extent of depth of field to the left and right of the red triangle on the *yellow* scale.

### Exposures with the Interchangeable Lenses

With the interchangeable lens units you use the same light value settings of the exposure meter as with the standard lens.

On inserting a Retina Reflex S lens, the aperture scale on the camera automatically locks at the maximum aperture of the lens, so that you cannot accidentally set an aperture-speed combination with too large a stop. On the Retina Reflex watch that you do not use lower aperture values (larger apertures) than the maximum aperture of the lens unit employed. With the  $f4$  telephoto and wide-angle lens units, the aperture on the camera must not be used wider open than  $f4$ , and the alternative  $f5.6$  wide-angle lens unit must not be used with the aperture on the camera wider than  $f5.6$ .

The standard lens of the Retina Reflex must *not* be changed against a standard lens from another Retina Reflex or from a Retina IIC or IIIC camera. Therefore, make sure that the serial number engraved on the lens itself is the same as the serial number engraved on the bayonet mount front plate of the camera.

## FOCUSING

The lens is focused at some definite distance. That means that its position relative to the film is adjusted in such a way that whatever is exactly at the focused distance will be represented by a "sharp" image on the film. Everything else—everything nearer to the camera or farther from it—will be, strictly speaking, "unsharp".

In practice the decline of definition is, of course, gradual. Thus there is a zone—stretching from somewhere in front of the focused distance to somewhere behind it—which will *appear* sufficiently sharp to the human eye. This is called *depth of field*.

Now, what should or should not be accepted as sufficiently sharp is debatable. Certain standards, however, have been agreed upon. It is agreed that any pin-point represented on a 35 mm. negative by a "dot", the diameter of which does not exceed  $1/30$  mm., should be regarded as sharp. The technical term for that "dot" is *circle of confusion*.

The limits defined by the circle of confusion vary with the type of lens and the conditions under which one definite type of lens is used:

*Short focus lenses yield more depth than long focus lenses.*

*Small apertures yield more depth of field than large ones.*

*Far focusing distances yield more depth of field than near focusing distances.*

### Control of Depth of Field

The depth of field—dependent on the distance actually focused at, the aperture employed and the focal length of the lens—has to be ascertained from case to case. Apart from the fact that the depth of field of the wide-angle and telephoto lenses of the Retina Reflex is different, there remains the interplay of "aperture" and "focusing distance". Their effect can be read off a depth of field calculator engraved on the lens barrel of the Retina Reflex lens or the pointers of the automatic depth of field indicator on the Retina Reflex S.

## FOCUSING

The lens is focused at some definite distance. That means that its position relative to the film is adjusted in such a way that whatever is exactly at the focused distance will be represented by a "sharp" image on the film. Everything else—everything nearer to the camera or farther from it—will be, strictly speaking, "unsharp".

In practice the decline of definition is, of course, gradual. Thus there is a zone—stretching from somewhere in front of the focused distance to somewhere behind it—which will *appear* sufficiently sharp to the human eye. This is called *depth of field*.

Now, what should or should not be accepted as sufficiently sharp is debatable. Certain standards, however, have been agreed upon. It is agreed that any pin-point represented on a 35 mm. negative by a "dot", the diameter of which does not exceed  $1/30$  mm., should be regarded as sharp. The technical term for that "dot" is *circle of confusion*.

The limits defined by the circle of confusion vary with the type of lens and the conditions under which one definite type of lens is used:

*Short focus lenses yield more depth than long focus lenses.*

*Small apertures yield more depth of field than large ones.*

*Far focusing distances yield more depth of field than near focusing distances.*

### Control of Depth of Field

The depth of field—dependent on the distance actually focused at, the aperture employed and the focal length of the lens—has to be ascertained from case to case. Apart from the fact that the depth of field of the wide-angle and telephoto lenses of the Retina Reflex is different, there remains the interplay of "aperture" and "focusing distance". Their effect can be read off a depth of field calculator engraved on the lens barrel of the Retina Reflex lens or the pointers of the automatic depth of field indicator on the Retina Reflex S.

## DEPTH OF FIELD

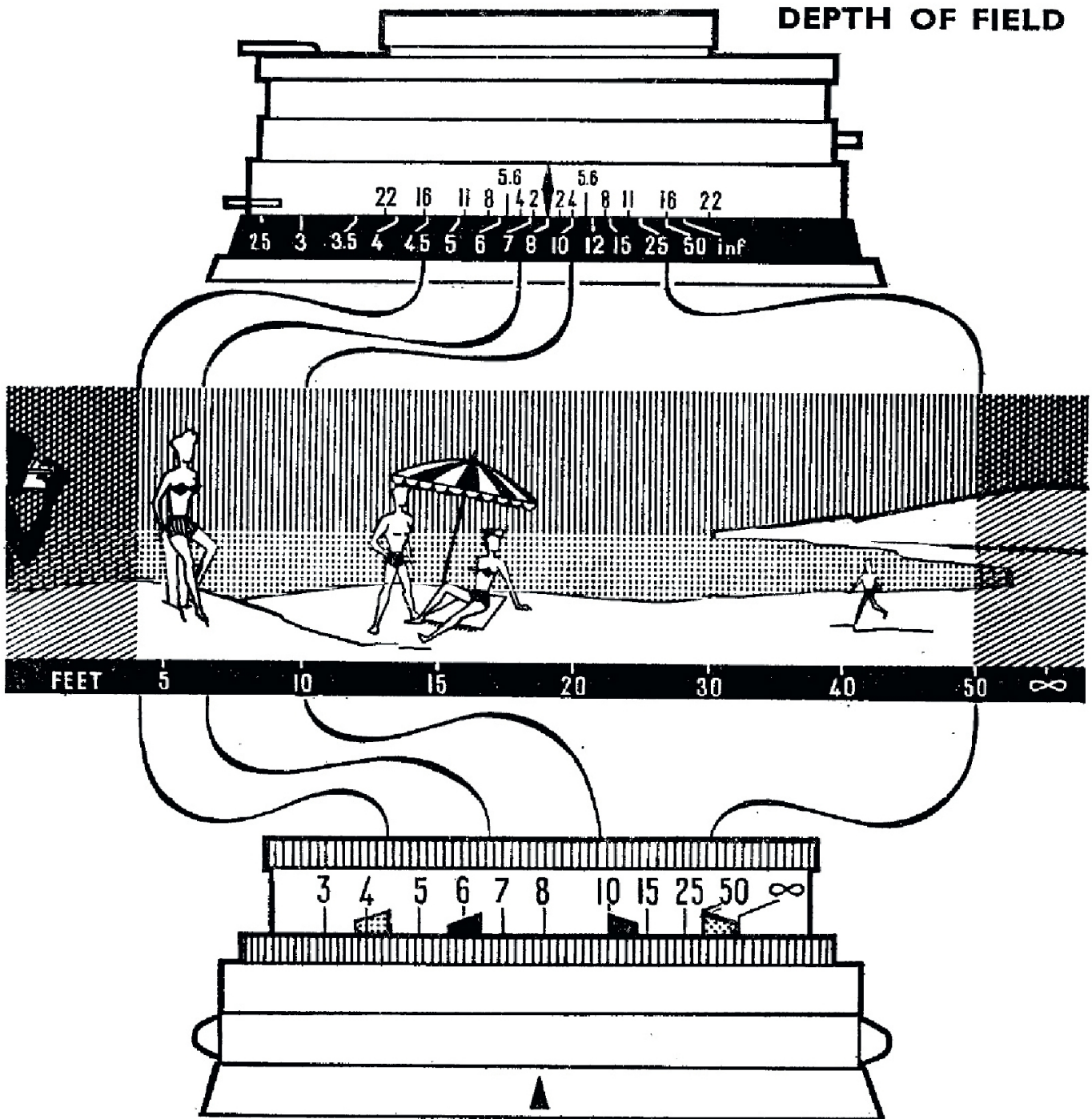

The depth of field scale shows clearly how much of the subject will be sharp at any given distance and aperture. The figure opposite the triangular index mark (top) is the focused distance (8 ft.). The figures to either side of the index mark represent aperture settings. If we then read off the distance opposite the aperture settings, we see indicated the area of sharp focus. So with an aperture of  $f/16$  this area extends from just under 5 ft. to about 50 ft. But at  $f/4$ , the depth of field is more limited, from just over 5 ft. to about 10 ft. On the Retina Reflex S two pointers directly show the depth of field zone (bottom). The pointers are coupled with the aperture control and move apart at small stop settings and together at large apertures.

the case of distant landscapes use should not be made of the *hyperfocal distance* (described on p. 63) if the sharpness is required in the far distance; focusing at the far distance will give better results.

When a lens is focused on such a distance that the depth of field just reaches the far distance (infinity) then the lens is focused on the "infinity-near point" or hyperfocal distance. This adjustment of focus is advisable when it is desired to secure adequate sharpness from the farthest distance to as far as possible in the foreground, rather than extreme sharpness in the far distance only.

### Depth with the Wide-angle and Tele Lenses

The depth of field, as already mentioned on p. 62, also depends on the focal length of the lens. It is considerably less with the telephoto lens, and appreciably more with the wide-angle lens. For instance, to take a setting of 10 ft. at  $f$  5.6, the depth with the 8 cm. lens extends from 9 ft. 2 in. to 11 ft. 1 in., as compared with about 7.5 to 15 ft. for the 5 cm. lens. On the other hand, the 3.5 cm. lens yields a sharp zone from 6 ft. 10 in. to 17 ft. 10 in.

The scale ring on the telephoto and wide-angle lens units of the Retina Reflex is solely for determining the depth of field (p. 54) and zone focus setting (p. 56). The alternative lenses of the Retina Reflex S each have their own coupled depth of field indicator.

### Quick Focusing

The Retina Reflex user will often aim at snapshots by seizing a situation as he comes across it without many preliminaries, certainly without setting up a tripod, and mostly with the least possible loss of time. To attain this he will have to know his camera not only inside out but he also needs a ready-for-shooting lens setting (= zone focusing), which will yield a sharp picture every time. Here the relatively short focal length of the standard Retina Reflex lens scores; it gives the advantage of a comparatively large depth of satisfactory definition even at the more open apertures.

From what was said about depth of field on the previous pages, it is clear that the stop is used to regulate the definition of our picture across the depth (both towards

## HYPERFOCAL DISTANCES

(For conversion into metric units, see p. 94)

Stop	With 5 cm. Lens		With 3.5 cm. Lens		With 8-8.5 cm. Lens	
	Distance Setting	Depth of Field from ∞ to	Distance Setting	Depth of Field from ∞ to	Distance Setting	Depth of Field from ∞ to
2	120 ft.	60 ft.	—	—	—	—
2.8	90 ft.	45 ft.	—	—	—	—
3.5	70 ft.	35 ft.	—	—	—	—
4	60 ft.	30 ft.	30 ft.	15 ft.	150 ft.	75 ft.
4.5	50 ft.	25 ft.	—	—	—	—
5.6	45 ft.	22 ft.	23 ft.	12 ft.	100 ft.	50 ft.
8	30 ft.	15 ft.	15 ft.	7½ ft.	75 ft.	37 ft.
11	22 ft.	11 ft.	12 ft.	6 ft.	50 ft.	25 ft.
16	15 ft.	7 ft.	7 ft.	3½ ft.	36 ft.	18 ft.

## ZONE FOCUSING

Subject	Stop	With 5 cm. Lens		With 3.5 cm. Lens		With 8-8.5 cm. Lens	
		Distance Setting	Depth of Field from to	Distance Setting	Depth of Field from to	Distance Setting	Depth of Field from to
Portraits	8	4 ft.	3½ ft. to 4½ ft.	—	—	6 ft.	5½ ft. to 6½ ft.
Children	8	6 ft.	5 ft. to 7½ ft.	6 ft.	4¼ ft. to 10 ft.	10 ft.	9 ft. to 11¼ ft.
Children	8	*10 ft.	7½ ft. to 15 ft.	*10 ft.	6 ft. to 30 ft.	*15 ft.	13 ft. to 18 ft.
Groups	8	12 ft.	9 ft. to 20 ft.	*10 ft.	6 ft. to 30 ft.	—	—
Landscapes	8	30 ft.	15 ft. to —	15 ft.	7½ ft. to ∞	70 ft.	35 ft. to ∞
Landscapes	11	22 ft.	10 ft. to —	—	—	*50 ft.	25 ft. to ∞

\* The Retina Reflex has a black circle near these distances to indicate useful focusing zones.

foreground and background) from the point at which the lens is actually focused. Now, the idea could occur to the beginner to try to use the smallest stop every time to make sure of sharp pictures. That, however, would mean that in the majority of cases he would not arrive at a practicable exposure time because, while it is true that the smaller the stop the greater the depth of field, it is also true that the smaller the stop the longer the exposure time.

In consequence, the best zone focusing is the compromise between a well-selected medium stop with a suitable distance setting, yielding a fairly extensive zone of definition and still leaving one to use a reasonably short exposure.

The more frequently used zone focusing settings are set out in our zone focusing table below and it may be found useful to copy them out on a piece of paper which can be fixed in the top flap of the camera case for ready reference.

## The Depth of Field Tables

These tables have been included in this book, in spite of the fact that the Retina Reflex is fitted with a depth of field calculator, in order to supply perfectly accurate figures which cannot be obtained with the calculator, the distance scale not being calibrated in sufficient detail.

The tables are computed on the assumption that the circle of confusion is of 1/30 mm. diameter. The figures on the left of the table relate to the setting of the lens stop. The bold (middle) figures in each group indicate the distance (*in feet*) to which the lens is to be set on the helical focusing scale. The corresponding figure above then gives the distance of the near limit (*in feet and inches*) and the figures below give the far limit (*in feet and inches*) of the depth of field.

The figures in the hyperfocal distance and zone focusing tables as well as in the depth of field tables may indicate more restricted zones of sharpness than obtained from the depth of field calculator. The reason for this is that the calculator or indicator on the camera is often based on a larger circle of confusion (e.g., 1/20 mm. or 1/500 in.), i.e., a greater tolerance of unsharpness than the tables. Where the negatives are not intended to be enlarged to more than about 4–5 diameters (post-card or half-plate size— $3\frac{1}{2} \times 5\frac{1}{2}$  to  $5 \times 7$  in.), the less strict standard of sharpness is quite adequate. However, if very big enlargements are required, or for work requiring higher accuracy, the more exact figures of the table should always be used.

For easy application of the tables with those cameras which have been made for the continental market and consequently have been calibrated in metres, a conversion table is given on p. 94.

DEPTH OF FIELD FOR THE STANDARD 5 cm. RETINA REFLEX AND REFLEX S LENSES

(For conversion into metric units, see p. 94)

f 1.9-2	3-10½	4-9½	6-7½	7-6½	9-3	10-11	17-2	35-5	121-1
	4	5	7	8	10	12	20	50	∞
	4-1½	5-2½	7-5	8-6½	10-11	13-4	23-11	85	∞
f 2.8	3-10	4-8½	6-5½	7-4	8-11½	10-7	16-3	31-9	86-6
	4	5	7	8	10	12	20	50	∞
	4-2½	5-3½	7-7½	8-9½	11-3	13-11	25-11	118	∞
f 3.5	3-9½	4-8	6-4½	7-2½	8-9	10-3	15-7	29-1	69-2
	4	5	7	8	10	12	20	50	∞
	4-2¾	5-4½	7-9½	9-½	11-8	14-6	28	178-8	∞
f 4	3-9½	4-7½	6-3½	7-1	8-7½	10	15-1	27-5	60-7
	4	5	7	8	10	12	20	50	∞
	4-3½	5-5½	7-10½	9-2½	11-11	14-11	29-9	283	∞
f 5.6	3-8	4-6	6-½	6-9½	8-1½	9-5	13-9	23-3	43-3
	4	5	7	8	10	12	20	50	∞
	4-4½	5-7½	8-3½	9-9½	12-11	16-6	36-11	∞	∞
f 8	3-6½	4-3½	5-8½	6-4½	7-6½	8-7½	12-1	18-11	30-3
	4	5	7	8	10	12	20	50	∞
	4-7	5-11½	9-½	10-9	14-10	19-8	58	∞	∞
f 11	3-5	4-1½	5-4	5-10½	6-11	7-9½	10-6	15-4	22
	4	5	7	8	10	12	20	50	∞
	4-10	6-5	10-2	12-5	18-1	25-11	202	∞	∞
f 16	3-2½	3-9½	4-9½	5-3½	6-½	6-8½	8-8	11-8	15-2
	4	5	7	8	10	12	20	50	∞
	5-4½	7-4½	12-9	16-7	28-7	55	∞	∞	∞
f 22	2-11½	3-5½	4-3½	4-8	5-3½	5-9½	7-1½	9-½	11
	4	5	7	8	10	12	20	50	∞
	6-1½	8-11	18-6	27-9	93-10	∞	∞	∞	∞

DEPTH OF FIELD FOR THE 8-8.5 cm. RETINA REFLEX AND REFLEX S LENSES  
(For conversion into metric units, see p. 94)

f 4	3-5	3-11	4-4	4-10	5-10	6-9	7-8	9-5	11-2	13-9	21-7	37-2	137-9
	3½	4	4½	5	6	7	8	10	12	15	25	50	∞
	3-7	4-1	4-7	5-2	6-3	7-5	8-7	10-9	13-3	16-11	30-9	80	∞
f 5.6	3-5	3-11	4-4	4-9	5-9	6-8	7-7	9-2	10-11	13-3	20-3	33-3	98-5
	3½	4	4½	5	6	7	8	10	12	15	25	50	∞
	3-7	4-2	4-8	5-3	6-4	7-7	8-9	11-1	13-6	17-9	33-2	102	∞
f 8	3-5	3-11	4-3	4-9	5-8	6-6	7-4	8-11	10-5	12-7	18-8	29-4	68-11
	3½	4	4½	5	6	7	8	10	12	15	25	50	∞
	3-8	4-3	4-8	5-4	6-6	7-9	9-1	11-8	14-6	19-2	39-4	183-8	∞
f 11	3-4	3-10	4-2	4-8	5-6	6-4	7-1	8-6	9-11	11-10	17	25-4	49-10
	3½	4	4½	5	6	7	8	10	12	15	25	50	∞
	3-9	4-4	4-10	5-6	6-8	8-1	9-6	12-6	15-8	21-3	49-8	∞	∞
f 16	3-3	3-9	4	4-6	5-3	6	6-8	8	8-11	10-9	14-5	20-7	34-5
	3½	4	4½	5	6	7	8	10	12	15	25	50	∞
	3-10	4-6	5	5-8	7	8-6	10-3	13-11	18-2	26-2	89	∞	∞
f 22	3-2	3-7	3-11	4-3	4-11	5-7	6-3	7-4	8-4	9-8	12-10	17	24-11
	3½	4	4½	5	6	7	8	10	12	15	25	50	∞
	4	4-9	5-3	6	7-6	9-4	11-5	16-2	22-3	35-10	139-5	∞	∞

All distances are measured from the subject to the film. For distances from 3½ to 6½ ft. a T1/60 supplementary lens is required (not on the 8.5 cm. lenses). See p. 56.

# DEPTH OF FIELD FOR THE 13.5 cm RETINA REFLEX S LENSES

(For conversion into metric units see p. 94)

<b>f 4</b>	13.7	15.6	17.4	19.2	23.9	28.2	45.0	81.5	137	430
	14	16	18	20	25	30	50	100	200	∞
	14.5	16.7	18.8	20.11	26.5	32.1	56.4	130	370	∞
<b>f 5.6</b>	13.5	15.4	17.1	18.11	23.3	27.6	43.3	75.10	122	308
	14	16	18	20	25	30	50	100	200	∞
	14.7	16.5	19	21.3	27.1	33	59.4	147	566	∞
<b>f 8</b>	13.3	15	16.9	18.5	22.7	26.6	40.10	68.9	104	215
	14	16	18	20	25	30	50	100	200	∞
	14.10	17.2	19.6	21.10	28	34.6	64.6	184	∞	∞
<b>f 11</b>	13	14.8	16.4	17.11	21.9	25.5	38.3	61.7	88.5	157
	14	16	18	20	25	30	50	100	200	∞
	15.2	17.7	20.1	22.8	29.4	36.8	72.5	271	∞	∞
<b>f 16</b>	12.7	14.2	15.8	17.1	20.7	23.10	34.7	52.5	70.8	108
	14	16	18	20	25	30	50	100	200	∞
	15.10	18.5	21.3	24.1	31.11	40.9	91.1	∞	∞	∞
<b>f 22</b>	12.2	13.7	14.11	16.3	19.4	22.1	31.1	44.7	56.11	78.8
	14	16	18	20	25	30	50	100	200	∞
	16.7	19.7	22.9	26.2	35.8	47.2	132	∞	∞	∞

All distances are measured from the subject to the film.

## DEPTH OF FIELD FOR THE 2.8 cm. RETINA REFLEX S LENSES

(For conversion into metric units, see p. 94)

2.8	3.0	3.5	3.9	4.1	4.8	5.3	6.9	10.2	14.6	20.2
f 4	3	4	4½	5	6	7	10	20	50	∞
	3.5	4.2	4.11	5.8	8.4	10.6	19.4	∞	∞	∞
<hr/>										
2.7	2.11	3.2	3.6	3.10	4.4	4.10	6	8.6	11.4	14.5
f 5.6	3	4	4½	5	6	7	10	20	50	∞
	3.8	4.6	5.4	6.4	9.11	13.1	31	∞	∞	∞
<hr/>										
2.5	2.8	2.11	3.2	3.5	3.10	4.3	5.2	6.10	8.6	10.1
f 8	3	4	4½	5	6	7	10	20	50	∞
	4.1	5.1	6.4	7.8	13.10	21.1	35.5	∞	∞	∞
<hr/>										
2.3	2.6	2.8	2.11	3.1	3.5	3.9	4.4	5.6	6.6	7.5
f 11	3	4	4½	5	6	7	10	20	50	∞
	4.9	6.2	8.1	10.7	14.1	27.9	∞	∞	∞	∞
<hr/>										
2	2.2	2.4	2	2.8	2.11	3.1	3.6	4.2	4.9	5.1
f 16	3	4	4½	5	6	7	10	20	50	∞
	6.5	9.8	15.5	28.8	92.1	∞	∞	∞	∞	∞
<hr/>										
1.9	1.11	2.1	2.2	2.3	2.5	2.7	2.10	3.3	3.7	3.9
f 22	3	4	4½	5	6	7	10	20	50	∞
	11.8	∞	∞	∞	∞	∞	∞	∞	∞	∞

All distances are measured from the subject to the film.

# DEPTH OF FIELD FOR THE 3.5 cm. RETINA REFLEX AND REFLEX S LENSES

(For conversion into metric units, see p. 94)

<b>f4</b>	2-4½	2-9	3-6	4-4	5-7	7-6	8-7	13-6	30-3
	2½	3	4	5	7	10	12	25	∞
	2-8½	3-4	4-7	5-10	9-0	14-10	19-8	150	∞
<b>f5.6</b>	2-4	2-8	3-5	4-2	5-4	6-10	7-9	11-8	21-4
	2½	3	4	5	7	10	12	25	∞
	2-9	3-5	4-10	6-5	10-2	17-10	26-10	∞	∞
<b>f8</b>	2-3	2-7	3-3	3-11	4-11	6-1	6-10	9-6	15-0
	2½	3	4	5	7	10	12	25	∞
	3-0	3-7	5-3	7-3	12-8	27-7	58-6	∞	∞
<b>f11</b>	2-2	2-5	3-0	3-7	4-5	5-4	5-11	7-9	11-0
	2½	3	4	5	7	10	12	25	∞
	3-1	3-11	6-0	8-9	18-5	92-0	∞	∞	∞
<b>f16</b>	2-0	2-4	2-9	3-2	3-9	4-5	4-10	5-11	7-8
	2½	3	4	5	7	10	12	25	∞
	3-6	4-7	7-10	13-7	79-5	∞	∞	∞	∞
<b>f22</b>	1-9	2-1	2-6	2-10	3-3	3-9	3-11	4-8	5-7
	2½	3	4	5	7	10	12	25	∞
	4-1	5-10	12-8	41-8	∞	∞	∞	∞	∞

All distances are measured from the subject to the film.

# EXPOSURE

Correct exposure depends on two sets of circumstances:

The amount and colour of light reflected from the object to be photographed. This, in its turn, depends on the season of the year, the time of day, situation, weather, etc.

The speed of film, the kind of filter used, the lens aperture employed and possibly an allowance for an increase in exposure in the case of special fine grain development.

## Using the Exposure Meter of the Standard Reflex

- 1. Set film speed.**
  - 2. Point camera to subject.**
  - 3. Turn setting ring to coincide yellow and white pointer.**
  - 4. Read off light value.**
  - 5. Transfer light value to shutter.**
1. Turn the inner disc of the exposure meter knob by the small knob near its circumference until the speed of the film used points to the arrowhead for the appropriate *DIN* or *ASA* value. (For film speed, see pp. 30, 31, 32.)
  2. See p. 72, "Working with an Exposure Meter". Make sure that the honeycomb meter window is not obscured by a finger.
  3. The white needle will move in the cut-out window (between body release and exposure meter wheel). Turn the meter setting ring (the outer milled ring of the exposure meter knob) until the yellow pointer lies exactly over the top of the white needle.
  4. Now read off the light value number opposite the red triangle (▲) on the inner disc of the exposure meter knob. If the triangle points to a position between two numbers, set the intermediate light value. For example, if the triangle points between 8 and 9, use 8.5 for greatest accuracy.
  5. Transfer the light value found with the meter to the shutter as described on p. 10.

## Using the Coupled Meter of the Retina Reflex S

- 1. Set film speed.**
- 2. Set shutter speed.**
- 3. Point camera at subject.**
- 4. Superimpose yellow and white pointers.**

## THE BUILT-IN EXPOSURE METER

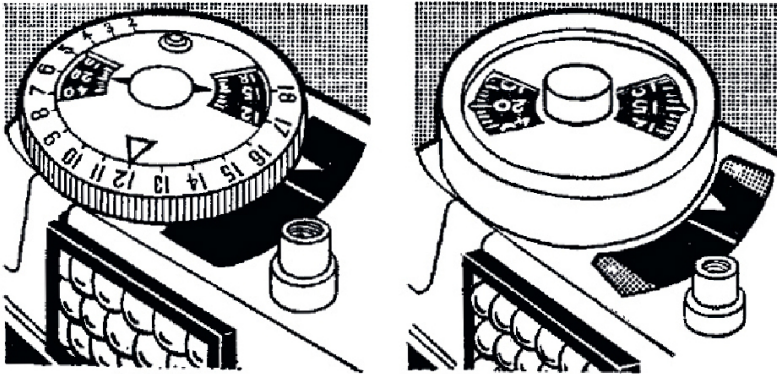

The exposure meter consists of a photo-cell, an indicating needle and setting marker, and a control. On the Retina Reflex the control knob gives light values (*extreme left*); on the Reflex S it only serves to set film speeds (*left*).

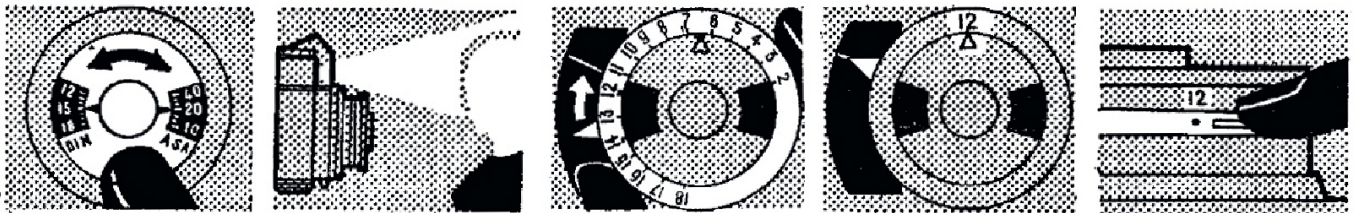

*Above, from left to right:* Taking readings with the Retina Reflex. Set the film speed, point the camera at the subject, turn the setting ring until the yellow pointer exactly covers the white meter needle, read off the light value, and set the shutter to the same light value (see p. 70).

*Right:* Using the coupled meter of the Retina Reflex S. Set the film speed (*top*) by pressing the button in the centre of the film speed dial and turning the setting wheel below the lens barrel. Point the camera at the subject and turn the setting wheel to superimpose the yellow pointer and white needle (*bottom*). The exposure is now correctly set on the camera.

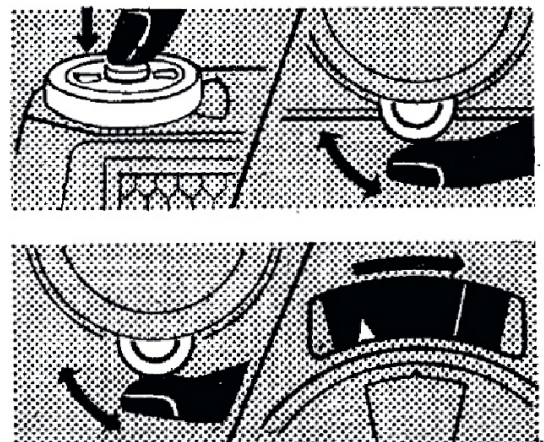

1. Depress the centre button of the meter disc and turn the setting wheel below the lens barrel until the required ASA or DIN film speed appears in the appropriate cut-out of the meter disc.
2. Turn the two black serrated keys on the shutter rim to set the required shutter speed—normally, say, 1/60 sec.—opposite the index mark.
3. See below, "Working with an Exposure Meter". Do not obscure the cell window with your fingers.
4. Turn the setting wheel below the lens barrel until the yellow pointer covers the white indicator needle of the meter.

The correct aperture is now set for the pre-selected shutter speed. If—as an afterthought—you want to change the shutter speed or aperture, turn the two black serrated keys around the shutter rim. Changing the shutter speed automatically adjusts the aperture, and vice versa, so that the exposure remains correct.

The white lines visible in the two corners of the meter window indicate the limits of the meter readings. If the white meter needle is outside these marks, the light conditions are too strong or too weak for the measuring range of the meter.

A resistance while you turn the setting wheel indicates that you have reached the limits of the aperture scale. If you turn on, you then also change the shutter speed to obtain a correct exposure setting.

## Working with an Exposure Meter

To get the best results the exposure meter has to be used intelligently. This may look like a contradiction, since we have already said that it is an accurate light measuring instrument. But light from all parts of the subject—highlights, shadows and middle tones—falls on the meter; so the reading it gives us is an average one for the whole subject area.

The Retina Reflex meter—as any other—is scaled to suit typically average subjects—i.e., subjects with average areas of light, dark and middle tones. So if you point the meter at a subject of this kind, the exposure reading will be correct.

But if the subject is not average—if there are large highlight areas and little shadow, or large shadow areas with few highlights—then you have to modify the exposure reading to obtain the best results.

So there is more to using a meter than just pointing it at the subject and accepting without question the reading indicated.

**REFLECTED LIGHT MEASUREMENT.** The usual method of using the meter is to point it directly at the subject. The light reaching the photo-electric cell is therefore that reflected by the subject, so this method is called "reflected light measurement".

This gives the correct exposure reading provided the subject has an average mixture of highlights, shadows and middle tones. But if there is a large bright area, or a large dark area, the best method is to go near to the main subject and take a close-up reading. For example, if

the subject is a figure against a white or dark background, by going closer you will reduce the amount of background affecting the meter and therefore get a reading in terms of a more average subject, which is what you want.

For some subjects you can take a reading from really close up, aiming the meter at the part of the subject that you want to make sure has optimum exposure. For instance, many photographers take a close-up reading of the sitter's face in portraiture; out-of-doors you can take the reading from the back of your hand instead of going up to the subject.

If you cannot go close up to a subject that needs a close-up reading, then try to find something near at hand that is similar in tone to the subject, and take a reading from this.

When taking readings of general scenes, including a good deal of sky, you have to tilt the meter down slightly to reduce the area of sky "seen" by the meter. The sky is a bright highlight, and by tipping the meter down to exclude some of it, the subject becomes "average" in tone range.

Open views, such as distant landscapes, usually have very light shadows, so you can give a shorter exposure than the meter indicates. It is usual to give half the exposure—i.e., use the next higher light value.

**INCIDENT LIGHT MEASUREMENT.** Another method of assessing exposure is to measure the strength of the light falling on the subject instead of that reflected by it. But if you point the meter straight at the light you get a much higher reading than if you point it at the subject. So the light has to be cut down for the meter to indicate the correct exposure. This is done by sliding the white diffuser supplied with the Retina Reflex over the honeycomb cell of the meter which is designed to reduce the light just the right amount. It also serves another important purpose, and this is to ensure that the meter includes all the light falling on the subject over an angle of almost a full 180°.

The incident light method is particularly useful for reversal colour films, and for subjects with contrasting backgrounds when it is impossible to make a close-up reading.

To take a reading, the method is simply to turn your back on the subject and point the meter in exactly the opposite direction. If the main light—say the sun—is coming from the side, don't just partly turn round and point the meter at this; turn round completely, and let the main light strike the meter at the same angle that it strikes the subject.

If the light on the subject is different from that on yourself at the camera position (say if the subject is in the shade, and you are in the sun), you must then go up to the subject and take the reading, pointing the meter towards the camera position.

When not in use the incident light diffuser can be stored under the elastic clip inside the top of the Retina Reflex ever-ready case.

## EXPOSURE TABLE FOR DAYLIGHT

Add the respective figures in the Tables 1, 2 and 3a; the correct exposure time can be taken from Table 4. For light value settings on the Retina Reflex add up the figures in the brackets of Tables 1, 2 and 3b. The result is the light value to be used on the shutter.

### 1. Subject and weather

	Clear sun	Cloudy light	Cloudy med.	Cloudy dull
Distant land or seascape without foreground ... ..	0 (13)	1 (12)	2 (11)	3 (10)
—with light foreground ...	1 (12)	2 (11)	3 (10)	4 (9)
Open streets, squares, light buildings ... ..	2 (11)	3 (10)	4 (9)	5 (8)
Figures, groups in open, near objects without heavy shade	3 (10)	4 (9)	5 (8)	6 (7)
—in shade ... ..	4 (9)	5 (8)	6 (7)	7 (6)
Average interiors, diffused light	10 (3)	11 (2)	12 (1)	13 (0)

### 2. Month and time

	May June July	Aug. April	Sept. March	Oct. Feb.	Nov. Dec. Jan.
11 a.m. to 2 p.m.	0 (3)	0 (3)	0 (3)	1 (2)	1 (2)
9 a.m. to 11 a.m. 2 p.m. to 4 p.m.	0 (3)	0 (3)	1 (2)	1 (2)	2 (1)
4 p.m. to 6 p.m.	1 (2)	1 (2)	2 (1)	2 (1)	3 (0)

### 3a. Film speed and aperture

Film speed	Stop							
	BS	f2	f2.8	f4	f5.6	f8	f11	f16
32°	0	1	2	3	4	5	6	
29°	1	2	3	4	5	6	7	
26°	2	3	4	5	6	7	8	

### 3b. Film speed

Factors
(1)
(0)
(-1)

### 4. Result (sum of Tables 1+2+3a)

Sum	6	7	8	9	10	11	12	13	14	
<b>Seconds</b>	<b>1/500</b>	<b>1/250</b>	<b>1/125</b>	<b>1/60</b>	<b>1/30</b>	<b>1/15</b>	<b>1/4</b>	<b>1/2</b>	<b>1</b>	
Sum	15	16	17	18	19	20	Sum 21	22	23	24
<b>74 Seconds 2</b>	<b>4</b>	<b>8</b>	<b>16</b>	<b>30</b>	<b>60</b>	<b>Minutes 2</b>	<b>4</b>	<b>8</b>	<b>16</b>	

**AGAINST THE LIGHT** subjects are extreme cases of non-average tone range. The main lighting becomes a very bright highlight in the field of view, so if you point the meter straight at the subject it will indicate too short an exposure and give you a silhouette effect in the final picture.

This is all right if you want a silhouette. But if you want correct exposure for the subject, you should either take a close-up reading, or take a reading from the camera position and give four to eight times the exposure indicated. Another way is to use the incident light diffuser on the meter, pointing it towards the subject from the camera position, and then double the exposure indicated.

**COLOUR FILMS** have only a small exposure latitude, so particularly careful reading is advisable. The meter is used in the same way as for black-and-white films, although the incident light method is often considered best for reversal films. This is because exposure of these should be based on the highlights, and the diffuser itself constitutes a highlight, with the meter in effect reading directly from it.

Because of the importance of the highlights, if you are using the meter without diffuser for an against the light shot, it is best to only double the reading, and not multiply it four to eight times as recommended for black-and-white negative films.

## USING FILTERS

The photographic black-and-white film, even when panchromatic, fails to render colours in their true black-and-white tone values, so that the photograph often gives quite a false impression of the real scene. Why?

Scientifically speaking, to the human eye yellow appears to be approximately over ten times as bright as blue, three times as bright as red, and one and a half times as bright as green. The average panchromatic film (p. 30), however, registers blue with a brilliance of about four-fifths that of yellow, green with one-third, and red with two-thirds of the brightness of yellow.

It is, therefore, evident that in order to obtain a colour rendering which will correspond with some degree of accuracy to impression of colours as perceived by our eye, the photographic sensitivity of the various colours compared with each other will have to be corrected. This can be achieved by the use of filters.

Filters are intended to control on our negative material the varying degrees of brightness. *They lighten objects of their own colour and darken those of their complementary colour* (e.g., a yellow filter will darken the blue of the sky). They may be used to obtain a colour rendering in our picture which corresponds more closely to the impression made upon our eye by the object: so we speak of "correction filters". Filters may also be employed to emphasise certain effects regardless of whether such emphasis is scientifically "correct" or not; for instance, our picture can be made to show heavy clouds against a particularly dark sky, whereas the actual landscape revealed only light clouds in a blue sky. Filters for such ends are termed "effect filters".

All filters cut out some part of the light and thus, as a compensation, an increase in exposure time is necessary when using them. Exact figures can only be given for each particular case, for the exposure ratio depends not only on the nature of the filter but also on the colour sensitivity of the film and on the colour of the prevailing light (p. 29).

The increase of exposure required is usually expressed by a filter factor, by which the normal exposure has to be multiplied. There are tables available which speak of 1.4 or 1.7 times the exposure, but we can cheerfully ignore these fractions and content ourselves with round figures, such as  $1\frac{1}{2}$ , 2, 3 times, and so on.

The Retina Reflex camera takes 32 mm. screw-in filters (32 mm. is the outside diameter).

The following list gives a summary of the filters recommended and a short explanation of their use. The *Focal Filter Chart* gives all filter data fully and at a glance.

#### FACTORS WITH RETINA REFLEX FILTERS

Filter	Filter code	Factor	Reduce light value setting by
Light yellow	F I	$1\frac{1}{2}$	$\frac{1}{2}$
Medium yellow	F II	2	1
Yellow green	F III	2	1
Orange	F IV	3	$1\frac{1}{2}$
Red	F V	7	3 ( $2\frac{3}{4}$ )
Blue	F VI	$2\frac{1}{2}$	$1\frac{1}{2}$ ( $1\frac{1}{4}$ )
Ultra-violet	—	—	—
Polarizing filter	—	$2\frac{1}{2}$	$1\frac{1}{2}$ ( $1\frac{1}{4}$ )

**YELLOW FILTERS** reduce the actinic effect of blue, rendering it darker and are, therefore, particularly suitable for landscape photography in order to obtain clearly defined cloud effects on a normal blue sky. In the case of a very light blue sky, use a darker filter and vice versa.

**YELLOW-GREEN FILTERS** give an effect similar to that of yellow filters, but also hold back red (renders it darker), to which some panchromatic films are comparatively over-sensitive (photographing it too light).

**ULTRA VIOLET FILTERS** are only to be employed at heights of 6,500 ft. (2,000 m.) above sea-level and over to avoid an unduly dark sky, such as would be obtained by using a yellow filter. At the same time they absorb the ultra-violet rays of high altitudes for which the lens is not corrected and which would reduce the definition.

**ORANGE FILTERS** give over-correction, and serve, therefore, as "effect" filters for depicting heavy clouds against a dark sky, and very clear distances in landscapes, eliminating light haze, etc.

**RED FILTERS** are of still stronger effect than the orange filter, for extreme contrast, creating black sky with brilliant clouds, faking sunshine into moonlight effects, etc.

**INFRA-RED FILTERS** are used only with infra-red film. Chiefly employed for scientific purposes, this combination penetrates mist in long-distance photography. When using infra-red film and filter, the special distance mark on the depth of field scale should be used instead of the elongated diamond mark. It consists of a small red dot just to the right of the diamond mark.

**BLUE FILTERS** are for panchromatic film in artificial light. They absorb part of the red sensitivity. This results in better skin-tones.

For filters for colour photography, see p. 51.

## **Polarizing Filter**

There are times when the judicious use of reflections will enhance the pictorial effect of the picture, but they are also frequently obtrusive and undesirable. Highly-polished subjects can be very difficult to illuminate successfully so as to obtain a true photographic rendering, since they will reflect too much light and so spoil the reproduction with a glare which obscures the detail. To overcome this difficulty the polarizing filter has been introduced. It consists of a layer of herapathite, cemented between two optical flat glasses. It suppresses light reflections from glass, china, enamel, polished wooden surfaces, water, etc. (but not metals). This filter will prove particularly useful when taking shop windows, furniture, photography of wet objects, etc. The effect is greatest when the camera points at a reflecting surface at an angle of about 35°.

The filter must be rotated to find out its best position on the lens. The Retina Reflex camera is ideal for this observation. The filter is simply held in front of the lens, and then slowly rotated to find the best or desired result on the reflex-focusing screen. Push the filter on to the lens in the position selected. As the polarizing filter is slightly tinted, the exposure time should be increased by reducing the light value setting by  $1\frac{1}{2}$ .

## CLOSE-UP WORK

### Supplementary Lenses

While the Retina Reflex normally focuses down to  $2\frac{1}{2}$  ft. (75 cm.), one can work at still shorter distances with the aid of the Retina supplementary lenses. These can be used with all except the 5 cm. Xenon  $f$  1.9 or the Heligon  $f$  1.9 lenses of the Retina Reflex S.

Two different lenses are available.

*Retina Supplementary Lens N1* (featuring mark: one ring around the circumference) for distances between  $38\frac{1}{4}$  and 18 in. (90 to 46 cm.) covering a subject field from  $17\frac{1}{2} \times 26\frac{3}{4}$  in. to  $8\frac{1}{2} \times 12\frac{3}{4}$  in. ( $45 \times 68.5$  cm. to  $21.5 \times 32.5$  cm.).

*Retina Supplementary Lens N2* (featuring mark: two rings around the circumference) for distances between 20 and 12 in. (50 to 30 cm.) covering a subject field from  $8\frac{1}{2} \times 12\frac{3}{4}$  in. to  $4\frac{1}{8} \times 6\frac{1}{8}$  in. ( $21.5 \times 32.5$  cm. to  $10.5 \times 15.5$  cm.).

N1 and N2 lenses can be used together (by screwing them into each other) for distances between  $14\frac{7}{8}$  and 12 in. (37.5 to 30 cm.) covering a field from  $5\frac{3}{4} \times 8\frac{5}{8}$  in. to  $4\frac{1}{8} \times 6\frac{1}{8}$  in. ( $14.5 \times 22$  cm. to  $10.5 \times 15.5$  cm.).

For ultra close-ups three two-element colour corrected, coated, supplementary R lenses, mounted in metal screw-in mounts, are designed for photographs at four fixed distances between 11 and 6 in.

*Lens R1:4.5* gives an approximate scale of reproduction of 1:4.5 covering a field of  $4\frac{1}{4} \times 6$  in. ( $11 \times 15.5$  cm.).

*Lens R1:3* gives an approximate scale of reproduction of 1:3 covering a field of  $2\frac{3}{4} \times 4\frac{1}{8}$  in. ( $7 \times 10.5$  cm.).

*Lens R1:2* gives an approximate scale of reproduction of 1:2 covering a field of  $1\frac{7}{8} \times 2\frac{3}{4}$  in. ( $4.75 \times 7$  cm.).

*Lens R1:4.5 combined with lens R1:2* gives an approximate scale of reproduction of 1:1.5, covering a field of  $1\frac{3}{8} \times 2$  in. ( $3.5 \times 5$  cm.).

Close-up lenses are screwed over the standard lens. The reflex ground glass screen of the camera shows the exact image covered free from parallax, and the picture can be **79**

focused in the same way as without a close-up lens.

At full aperture the definition falls off slightly, especially towards the corners, and the camera lens should be stopped down to about  $f5.6$  in the case of the N lenses and to  $f8$  when using the R close-up lenses to regain full edge definition. No change of exposure time is required.

Where the original Retina close-up lenses are not available, any photographic dealer or optician will be in a position to supply a range of meniscus type lenses, of suitable size, to be put into a 32 mm. push-on filter mount. The lenses suggested are +1 diopter, +2 diopters, +3 diopters. These do not fully coincide with the Retina supplementary lenses.

*The +1 Diopter Lens:* for distances from 39.4 in. to  $20\frac{1}{2}$  in. The approximate field covered at  $\infty$  setting of the Retina Reflex lens is  $28 \times 18\frac{1}{2}$  in.; at  $3\frac{1}{2}$  ft. setting  $14 \times 9\frac{3}{8}$  in.

*The +2 Diopter Lens:* for distances from 20 in. to 13 in. The field covered at  $\infty$  setting is  $14 \times 9\frac{3}{8}$  in.; at  $3\frac{1}{2}$  ft. setting  $9\frac{1}{4} \times 6\frac{1}{8}$  in.

*The +3 Diopter Lens:* for distances from 13.1 in. to 10 in. The field covered at  $\infty$  is  $9\frac{3}{8}$  in.  $\times$   $6\frac{1}{4}$  in.; at  $3\frac{1}{2}$  in. setting  $6\frac{7}{8}$  in.  $\times$   $4\frac{1}{2}$  in.

#### CLOSE-UP FOCUSING TABLE FOR +1, +2, +3, DIOPTRER LENSES

Set distance on helical focusing mount to:		With +1 diopter lens, the distance from front of lens to subject is:		With +2 diopter lens, the distance from front of lens to subject is:		With +3 diopter lens, the distance from front of lens to subject is:	
ft.	m.	in.	cm.	in.	cm.	in.	cm.
	$\infty$	39.4	100	19.7	50	13.1	33
40	20	36	95	19	49	12.7	32.5
20	10	33.8	90.5	18.2	47.5	12.4	32
13	6	31	85.5	17.5	46	12.1	31.5
10	4	29.7	80	16.9	44.5	11.8	31
8	3	28	75	16.7	43	11.7	30
7	2	26.9	67	16.4	40	11.6	28.5
5	1.5	23.8	60	14.9	37.5	10.8	27
4	1.2	21.7	54.5	14	35	10.3	26
3.5	1	20.5	50	13	33	10	25

*The metric and inch figures in this table are not necessarily exact equivalents; each set of figures does, however, indicate the correct distances for any setting of the corresponding focusing scale. Therefore, always use the distances in centimetres only with the focusing scale settings in metres and the inch measurements with focusing scale settings in feet. For exact conversions see p. 94.*

## CLOSE-UP LENSES

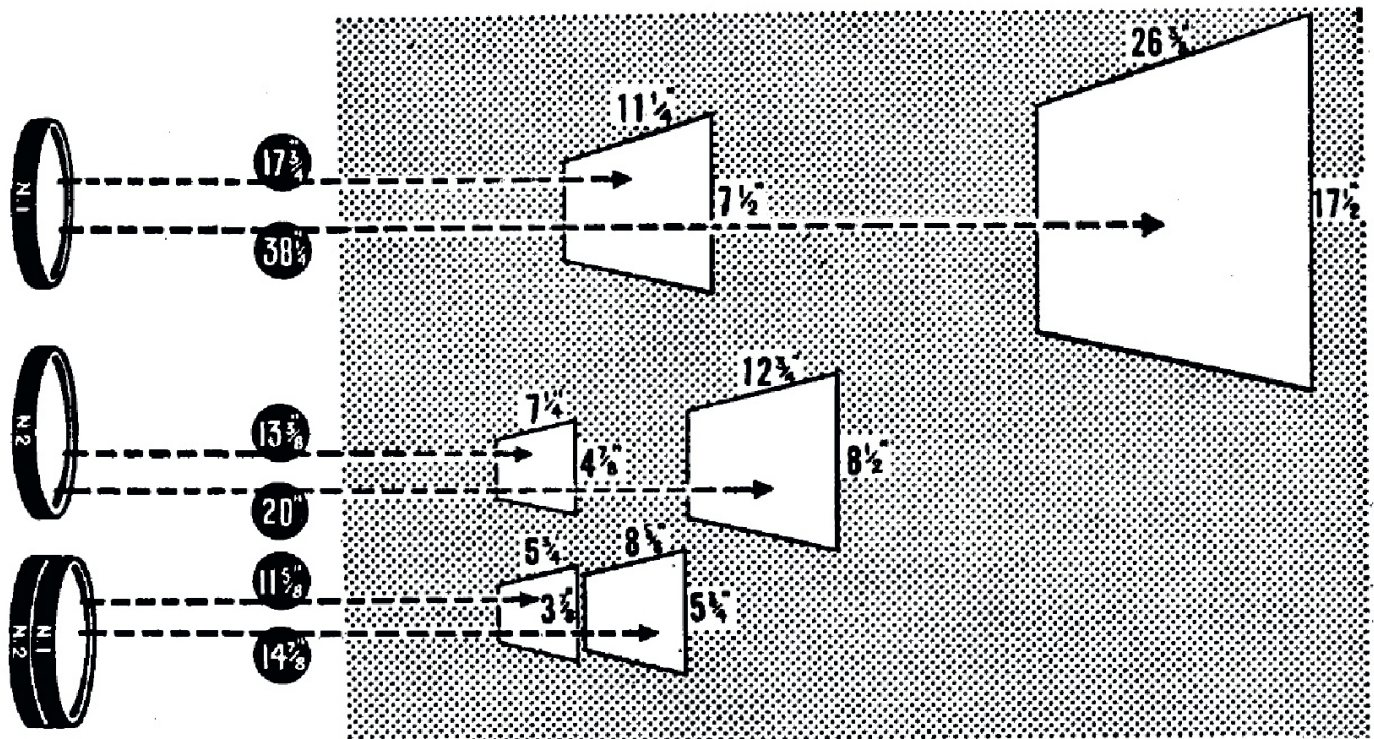

The N1 supplementary lens allows focusing between  $38\frac{1}{2}$  in. and  $17\frac{1}{2}$  in. and at these distances the field covered is  $26\frac{3}{8} \times 17\frac{1}{2}$  in. and  $11\frac{1}{4} \times 7\frac{1}{2}$  in. respectively. The N2 lens allows focusing between 20 in. and  $13\frac{3}{8}$  in. and again at these distances covers a field of  $12\frac{3}{4} \times 8\frac{1}{2}$  in. and  $7\frac{1}{4} \times 4\frac{7}{8}$  in. respectively. Mounted together, even closer distances can be focused, from  $14\frac{7}{8}$  in. to  $11\frac{5}{8}$  in. Here the field covered is  $8\frac{5}{8} \times 5\frac{3}{4}$  in. and  $5\frac{3}{4} \times 3\frac{7}{8}$  in. respectively.

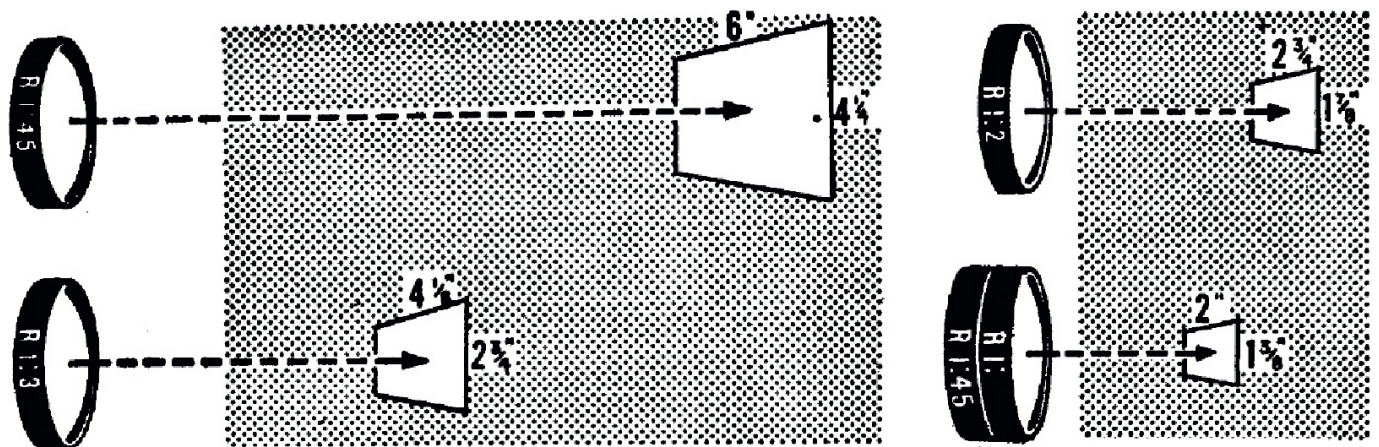

For ultra close-up work three supplementary R lenses are available. R1:4.5 gives an approximate scale of reproduction of 1:4.5 and covers a field of  $6 \times 4\frac{1}{4}$  in. R1:3 gives an approximate scale of reproduction of 1:3 and covers a field of  $4\frac{1}{8} \times 2\frac{3}{4}$  in. R1:2 gives an approximate scale of reproduction of 1:2 and covers a field of  $2\frac{3}{4} \times 1\frac{7}{8}$  in. R1:4.5 combined with R1:2 gives an approximate scale of reproduction of 1:1.5 and covers a field of  $2 \times 1\frac{3}{8}$  in.

The depth of field when working at close range with the supplementary lenses is obviously rather limited. The table on p. 86 gives the extent of depth of field for close up work. These are firm indications of the depth of field to be expected when working at such short lens-subject distances. The figure on the left of the groups is the aperture, the bold middle figure gives the distance from front of lens to subject according to the table on page 83, while the top figure above gives the near limit, the row below the far limit of the depth of field.

## The Close-up Attachment

When working with the ultra-close R lenses the reflex ground glass will, of course, permit parallax-free focusing. Nevertheless for close-ups of live subjects the use of the Retina close-up attachment is recommended. It consists of a camera platform which takes four alternative sets of legs which act as a distance gauge and show the correct field area covered at the same time.

To use it, screw the R lens required to the camera lens and clamp the corresponding set of two legs into the appropriately marked notches of the attachment. Then approach the subject until it is in the plane of the gauge rods fixed into the front ends of the legs. See illustration, p. 85.

## The Table Stand

The table stand has been developed for close-up subjects which allow or need longer exposure times as well as for all types of close-ups where quick setting-up and absolute steadiness of the camera is important.

The stand consists of a U-shaped base with an adjustable column and a ball and socket head. The latest version has, in addition, a baseplate to support the camera in its centre. The stand can be taken apart into its individual components for easy transport and storage. It is specially useful for close-ups with the N close-up lenses. Alternatively, the ultra close-up lens set R1:2, R1:3 and R1:4.5 can be used with the table stand in conjunction with a frame holder and close-up field frames showing the correct distance and field with these R lenses. This ultra-close-up attachment for the table stand is, however, no longer in production. (See illustrations, p. 85).

**CLOSE-UP FOCUSING TABLE FOR RETINA REFLEX SUPPLEMENTARY LENSES (INCHES)**  
*(For conversion to metric units, see p. 94)*

Camera Lens Focusing Scale Setting (Feet)	RETINA REFLEX LENS N1		RETINA REFLEX LENS N2		RETINA REFLEX LENSES N1 + N2	
	Supplementary Lens to Subject Distance (in inches)	Approximate Field Size (in inches)	Supplementary Lens to Subject Distance (in inches)	Approximate Field Size (in inches)	Supplementary Lens to Subject Distance (in inches)	Approximate Field Size (in inches)
∞	38½	17½ × 26½	20	8½ × 12½	14½	5½ × 8½
50	35½	16½ × 24½	19½	8½ × 12½	14½	5½ × 8½
25	34½	15½ × 23½	19	8 × 12	14½	5½ × 8½
15	32½	14½ × 22	18½	7½ × 11½	14½	5½ × 8
12	31½	13½ × 20½	18	7½ × 11½	14	5½ × 7½
10	30	13½ × 19½	17½	7½ × 11	13½	5½ × 7½
8	28½	12½ × 18½	17½	7½ × 10½	13½	5 × 7½
7	27½	11½ × 17½	16½	6½ × 10½	13½	5 × 7½
6	26½	11½ × 17½	16½	6½ × 10	13½	4½ × 7½
5	24½	10½ × 16	16½	6½ × 9½	12½	4½ × 7
4.5	24	10½ × 15½	15½	6½ × 9½	12½	4½ × 6½
4	22½	9½ × 14½	15½	5½ × 8½	12½	4½ × 6½
3.5	21½	9 × 13½	14½	5½ × 8½	12½	4½ × 6½
3	19½	8½ × 12½	14½	5½ × 7½	12	4½ × 6½
2.5	17½	7½ × 11½	13½	4½ × 7½	11½	3½ × 5½

## The Copying Stand

For quick and convenient copying of documents, important letters, valuable prints, book pages and the like from about  $6 \times 8$  in. to  $8 \times 12$  in. in size a special copying stand has been designed.

The outfit consists of a camera holder which takes four extendible legs. The bottom ends of the legs are fixed into the four corners of a glass plate which is laid on top of the document or other matter to be copied.

The N2 supplementary lens is used. The legs are used fully extended with the lens set to infinity, and fully pushed in (a different baseplate is used) with the lens set to the nearest distance. A special lighting unit consisting of two adjustable lamp reflectors with arms fixing to the camera holder is available as an extra (illustrated on p. 85).

## The Micro-Adaptor

For making photographic records in black-and-white or colour of microscope investigations, the Retina Reflex micro-adaptor is useful and simple to handle.

The micro-adaptor allows the Retina Reflex camera (but not the Reflex S with  $f$  1.9 Xenon or Heligon) to be used with any microscope with a standard eyepiece diameter of 25 mm. The attachment consists of a light metal body with a focusing eyepiece at the front and an arm to hold the camera at the back.

To make photomicrographs with the Retina Reflex, remove the microscope eyepiece, connect the microscope tube to the micro-attachment, and re-insert the eyepiece. Mount the Retina Reflex on the camera bracket. Focus through the focusing eyepiece of the attachment using the coarse and fine adjustment of the microscope. The focusing scale of the camera must be set to infinity and the lens to its largest aperture. (See illustration on p. 85.)

## The Stereo Attachment

84 Stereoscopic photographs may be taken with the Retina Reflex camera (not Reflex S) by taking two pictures, one

## CLOSE-UP EQUIPMENT

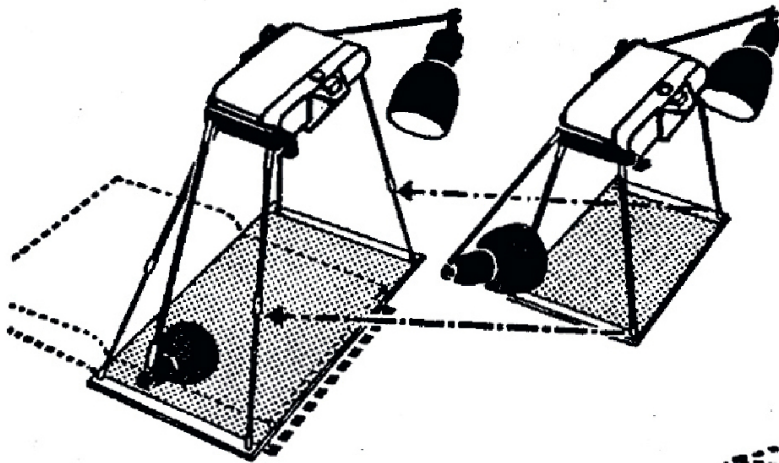

*Left:* The Retina copying outfit consists of a camera holder with extendible legs and incorporates its own lighting unit. It is used with the N2 supplementary lens and covers two field sizes (p. 79).

*Right:* The micro-adaptor enables the Retina Reflex to be used with most microscopes.

*Extreme right:* The close-up attachment is a simplified version of the combination of table stand and field frames.

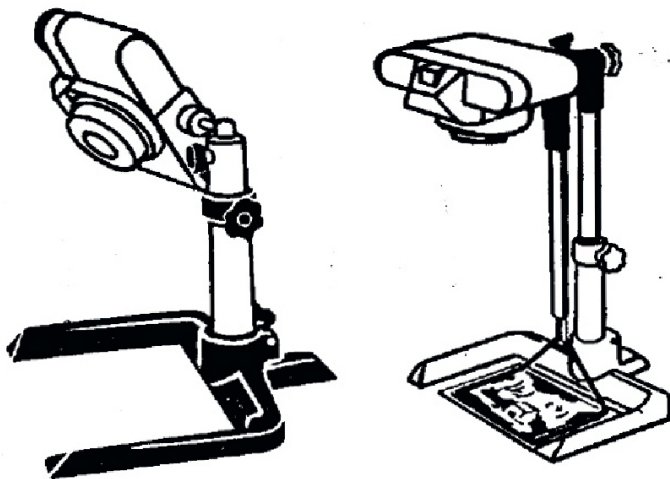
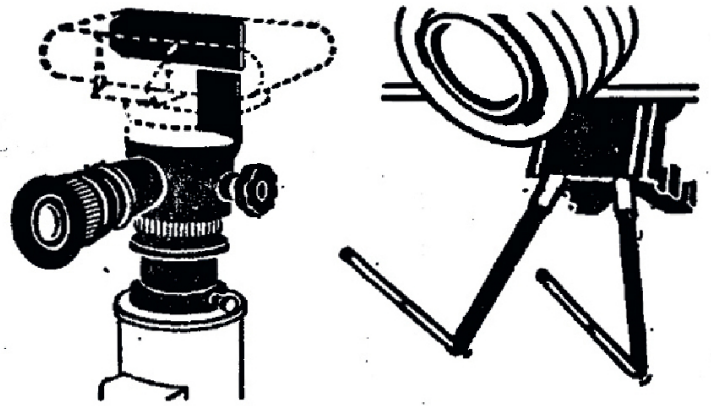

*Extreme left:* The Retina table stand used with the N supplementary lenses and (*left*) the stand in use with R lenses and a frame holder taking close-up field frames.

*Right:* The stereo attachment fitted to the Retina Reflex. An optical system produces two upright pictures side by side with the correct stereo separation.

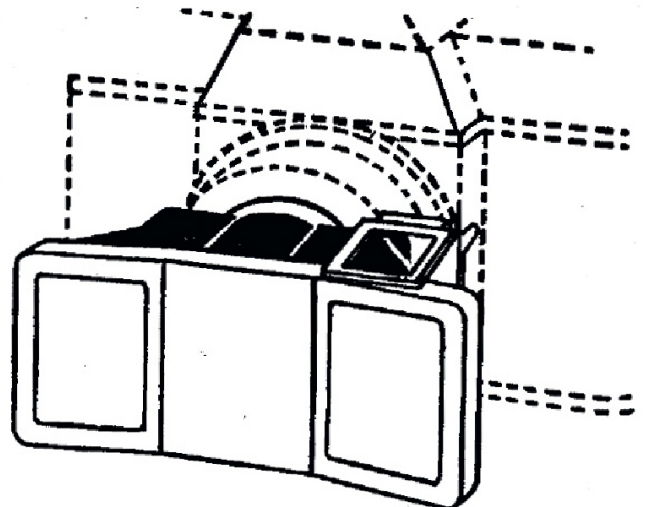

## CLOSE-UP DEPTH OF FIELD TABLE

(For conversion into metric units, see p. 94)

f 3.5	37 $\frac{3}{8}$	33 $\frac{1}{4}$	29	25 $\frac{1}{8}$	20 $\frac{1}{2}$	19 $\frac{1}{8}$	15 $\frac{3}{8}$	11 $\frac{7}{8}$	10 $\frac{1}{8}$
	39 $\frac{1}{2}$	35	30	26	21	19 $\frac{1}{2}$	16	12	11
	41 $\frac{3}{8}$	36 $\frac{1}{4}$	31 $\frac{1}{4}$	26 $\frac{1}{2}$	21 $\frac{3}{8}$	20	16 $\frac{1}{4}$	12 $\frac{1}{4}$	11 $\frac{3}{8}$
f 5.6	36 $\frac{1}{8}$	32 $\frac{3}{8}$	28 $\frac{1}{8}$	24 $\frac{3}{8}$	20 $\frac{1}{8}$	18 $\frac{3}{8}$	15 $\frac{3}{8}$	11 $\frac{3}{4}$	10 $\frac{1}{4}$
	39 $\frac{1}{4}$	35	30	26	21	19 $\frac{1}{4}$	16	12	11
	42 $\frac{1}{2}$	37 $\frac{1}{8}$	31 $\frac{3}{8}$	27 $\frac{1}{8}$	22	20 $\frac{3}{8}$	16 $\frac{1}{2}$	12 $\frac{3}{8}$	11 $\frac{3}{8}$
f 8	35 $\frac{1}{8}$	31 $\frac{1}{4}$	27 $\frac{3}{8}$	24 $\frac{1}{8}$	19 $\frac{3}{4}$	18 $\frac{1}{8}$	15 $\frac{3}{8}$	11 $\frac{1}{8}$	10 $\frac{1}{8}$
	39 $\frac{1}{4}$	35	30	26	21	19 $\frac{1}{4}$	16	12	11
	44 $\frac{3}{8}$	38 $\frac{1}{8}$	32 $\frac{1}{8}$	28	22 $\frac{1}{4}$	20 $\frac{1}{8}$	16 $\frac{3}{8}$	12 $\frac{3}{8}$	11 $\frac{1}{8}$
f 16	32 $\frac{1}{4}$	29 $\frac{1}{8}$	25 $\frac{3}{8}$	22 $\frac{1}{4}$	18 $\frac{3}{8}$	17 $\frac{1}{8}$	14 $\frac{1}{4}$	11 $\frac{1}{8}$	10 $\frac{1}{8}$
	39 $\frac{1}{4}$	35	30	26	21	19 $\frac{1}{4}$	16	12	11
	51 $\frac{1}{4}$	43 $\frac{1}{4}$	35 $\frac{1}{8}$	30 $\frac{1}{8}$	24 $\frac{3}{8}$	22 $\frac{3}{8}$	17 $\frac{1}{4}$	13 $\frac{3}{8}$	12

immediately after the other. For this purpose parallelogram or sliding base attachments are available each giving the correct separation of 64 mm. Both types of attachment must be used in conjunction with a tripod and are only suitable when the subject photographed is stationary.

A more convenient method of taking stereoscopic photographs with the Retina Reflex is, however, to use the stereo attachment. This consists of an optical system which produces two upright pictures side by side each measuring  $16 \times 22$  mm. The prisms are so arranged that the two pictures are taken with the correct separation of 64 mm. which corresponds with the average separation between human eyes.

To use the stereo attachment, fit it over the standard lens by lining up the red dot on the rear of the attachment with the red dot on the camera lens. The attachment is then turned clockwise into a horizontal position to engage. The ground glass reflex image shows the correct double image and permits focusing in the usual way.

Stereoscopic pictures can be taken at distances from 6 ft. to infinity.

Exposure times are unchanged for apertures of  $f5.6$  and smaller with the stereo attachment. For wider apertures double the exposure indicated by the meter by reducing the light value by 1.

## FLASH PHOTOGRAPHY

Flash is an efficient light source where no or insufficient daylight is available, such as at night, indoors, etc. In the flash light you carry your own private "sun" with which you can illuminate your subject or scene at any time and place no matter what other light is available.

The flash bulb is similar to a small electric bulb. However, when current passes through it, it lights up in an intense flash lasting usually about  $1/40$  to  $1/60$  sec. Each bulb will flash only once and has to be discarded afterwards.

The flash bulb is inserted in a battery case, and the current of the battery is used to set off the bulb. A reflector behind the bulb makes sure that all the light reaches the subject.

The most efficient types of flash gun incorporate a capacitor unit which increases the reliability of firing, even when the battery is nearly exhausted. The light of the flash bulb is strong enough to allow medium to small apertures to be used for the exposure. The shutter speed—provided it is slower than  $1/30$  to  $1/60$  sec.—has no effect on exposure since the flash is shorter than the exposure time. Faster speeds can be used if the shutter is fully synchronized.

An electrical cable connects the battery case to the flash socket by means of a special plug. On releasing the shutter an electric circuit is automatically closed through the flash socket when the shutter is fully open, setting off the flash at this very moment.

Electronic flash units utilize the discharge of a high-tension capacitor through a flash tube. The power is derived from an accumulator or battery (there are also models working from the mains electricity supply). The electronic flash outfit is rather bigger and heavier than the flash bulb outfit, its comparative light output equals the average flash bulb and its initial cost is higher. On the other hand, anything from 10,000 to 25,000 flashes are obtained from one tube. The flash duration is extremely short ( $1/700$  to  $1/2000$  sec.) and will arrest the fastest movements. The cost of an

**88** individual exposure is negligible.

## FLASH PHOTOGRAPHY

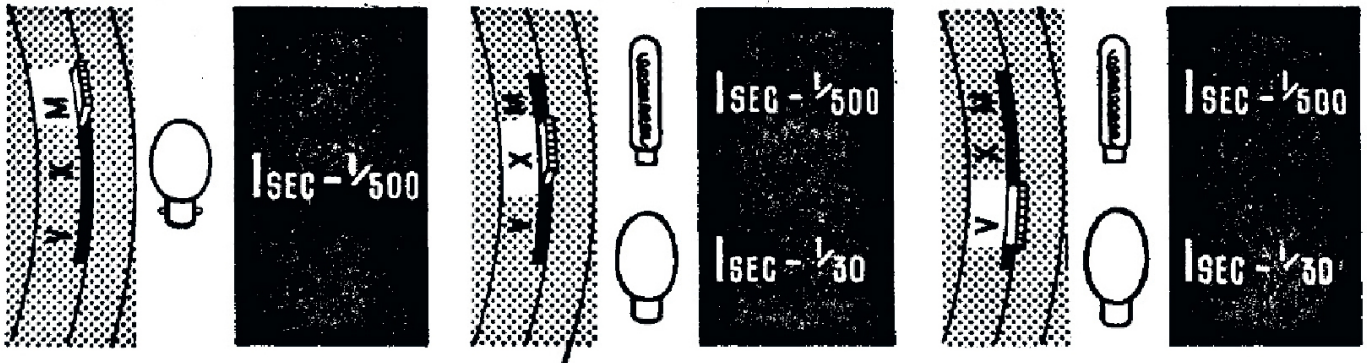
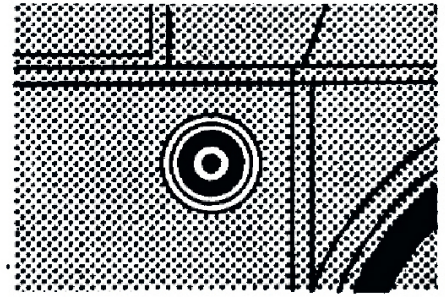
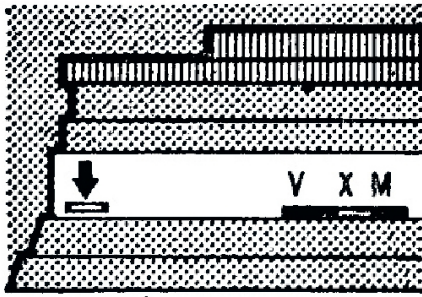

Above: The synchronizing settings, showing also the synchronizing locking lever (top left): the flash socket on the camera front which accepts the flash gun lead (top right). At the M setting, flash bulbs can be synchronized with any shutter speed from 1 to 1/500 sec. (left). At the X setting, electronic flash will synchronize at any speed from 1 to 1/500 sec., but flash bulbs only to 1/30 sec. (centre). The V setting controls the delayed-action release and synchronizes in the same way as the X setting.

Right: More natural-looking lighting results from "bouncing" flash light from a light surface (i.e., a ceiling). For ease of operation, the flash gun can be fitted into a shoe on a movable ball which itself fits into the camera accessory shoe.

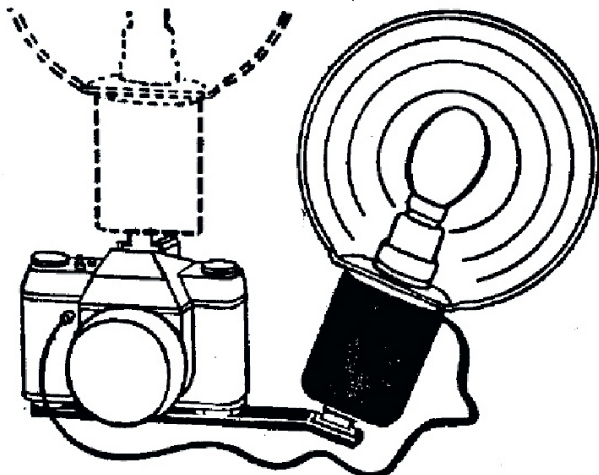
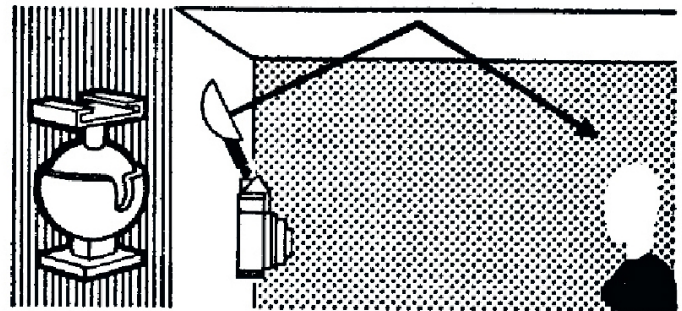

Left: The Kodablitz flash gun for the Retina Reflex uses a capacitor unit and a 22.5-volt miniature battery. The gun will fit either into the accessory shoe on the camera, or on to a bracket which is screwed into the tripod bush.

## How to use Flash

The Synchro-Compur shutter of the Retina Reflex is internally speed synchronized for flash. That means that you can take flash shots at all shutter speeds up to the fastest setting of 1/500 sec. with any flash bulb or electronic flash unit.

The depth of field ring carries three engraved letters, M, X and V, next to the green synchronizing lever. M and X are synchronized settings for flash, while V is the self-timer setting (see p. 12).

The green synchronizing lever for flash (M and X) and the self-timer (V) is also connected to a locking lever; this is the small projecting stud let into the depth of field ring near the base of the camera. The synchronizing lever can only be moved after pressing the locking lever. This avoids errors due to accidental movement of the synchronizing lever.

For flash shots with electronic flash move the synchronizing lever to the X position. Any shutter speed can then be set and the firing of the flash will coincide with the moment when the shutter is fully open. Flash bulbs can be used with the lever at the X setting, but not at any shutter speed faster than 1/30 sec.

Most present-day flash bulbs are what are known as M-class bulbs. This means that they have a slight firing delay (about 20 milliseconds). When the synchronizing lever is set to M these flash bulbs will accurately synchronize with the shutter at all shutter speeds. What actually happens is that on pressing the shutter release the flash is fired, then the shutter starts to open. When it is fully open the flash has just reached its peak brilliance.

A table showing suitable shutter speeds with flash is given on p. 92.

If the self-timer is used with flash the shutter works as for X-synchronization. So if you are using flash bulbs do not use a shutter speed faster than 1/30 sec.

Normally the flash gun is fitted into the accessory shoe  
**90** on top of the Retina Reflex or else attached to the camera by

means of a bracket. In either case it points directly at the subject to be photographed. While this method will give satisfactory results, a more pleasing form of illumination can be achieved by "bouncing" the flash. To do this the flash gun is angled so that the light "bounces" off a light ceiling or wall on to the subject. The advantage of this method is that it gives a softer light more akin to daylight, and avoids the hard shadows normally associated with flash. However, a wider aperture is required than for direct flash.

To facilitate the tilting of the flash gun a ball joint adaptor is available to fit in the camera accessory shoe and hold the gun. It can then be angled in any direction.

### The Correct Aperture

The correct aperture to use with some of the more common flash bulbs is shown on p. 92. It assumes they are used in an efficient reflector in a room of average brightness and with a shutter speed up to 1/30 sec. with a film speed of 30-32° B.S.

In bright rooms, or with films faster than 32° B.S., use the next smaller aperture. In very large rooms, at night outdoors, or with slow 27-29° B.S. film use the next larger aperture.

The *Focal Flash Chart* is a simple and convenient ready means of reading off the correct aperture to use for any flash bulb at any distance, shutter setting and film speed and shows typical flash set-ups.

### Guide Numbers

There is a convenient way of working out exposures with flash, and this is by means of a guide number. When you buy flash bulbs you will always find the guide number for any speed of film printed on the packet.

To find the correct aperture to use, divide the guide number by the distance between the flash and the subject. For instance, suppose you find that the guide number of the bulb with the film in use is 160. If you then want to take a photograph at a distance of 10 ft. from the subject, divide

## SYNCHRONIZED SHUTTER SPEEDS

Flash	Shutter Speed (sec.) Synchro-lever set to	
	X	M
Sylvania SF	1-1/60	—
Philips PF 1, 5, 25, 38, 60	1-1/30	1-1/500
Mazda No. 1, 5,		
G.E.C. No. 1, 5,		
Philips PF 100	1-1/8	1/30-1/60
Electronic flash	1-1/500	—

### APERTURES WITH CLEAR FLASH BULBS (For black-and-white film, 30-32° BS at 1/30 sec.)

Distance	Sylvania SF Mazda or G.E.C., No 1 Philips PF 1	Mazda or G.E.C. No. 5 Philips PF 5, 25	Philips PF 38	Philips PF 60
6 ft. (2 m.)	f 16	—	—	—
8 ft. (2.5 m.)	f 12.5	—	—	—
10 ft. (3 m.)	f 10	f 16	—	—
12 ft. (3.6 m.)	f 8	f 16	f 16	—
15 ft. (4.5 m.)	f 6.3	f 11	f 12.5	f 16
20 ft. (6 m.)	f 4.5	f 8	f 10	f 12.5
25 ft. (7.5 m.)	f 4	f 6.3	f 8	f 11
30 ft. (9 m.)	f 3.5	f 5.6	f 6.3	f 9

### APERTURES WITH BLUE FLASH BULBS (For 22° BS Daylight Type Colour Film)

Distance	PF 1/97	PF 5/97, 25/97	No. 5B	PF 60/97
3½ ft. (1 m.)	8	16	8-11	—
5 ft. (1.5 m.)	5.6	11	5.6-8	16
7 ft. (2.2 m.)	4	8	4-5.6	11
10 ft. (3 m.)	2.8	5.6	2.8-4	8

$160 \div 10 = 16$ . Therefore, the correct aperture to use is  $f16$ . Alternatively, if you want to use an aperture of  $f8$  for any reason, then the correct flash distance is  $160 \div 8 = 20$ . So the flash must be 20 ft. from the subject.

So far we have assumed that the exposures have been for average shots without much subject movement. For these a shutter speed of  $1/30$  sec. is long enough to utilize all the light emitted from the bulb. On the other hand, to arrest fast movements a faster shutter speed is required, such as  $1/125$ ,  $1/250$  or even  $1/500$  sec. With each of these speeds a different guide number is needed (usually printed on the flash bulb packet) to determine the correct exposure. They allow for a wider aperture to compensate for the fact that at fast shutter speeds some of the light emitted from the bulb is lost.

## CONVERSION OF FEET AND INCHES INTO METRIC UNITS

Many cameras are marked only in either the metric or British system, while most of the tables in this book are also given in only one system. The table below shows at a glance equivalent lengths.

British to Metric.		Metric to British.	
$\frac{1}{8}$ in.	0.32 cm.	0.5 cm.	$\frac{3}{16}$ in.
$\frac{1}{4}$ in.	0.64 cm.	1 cm.	$\frac{2}{8}$ in.
$\frac{1}{2}$ in.	1.27 cm.	2 cm.	$\frac{13}{16}$ in.
1 in.	2.54 cm.	3 cm.	$1\frac{3}{16}$ in.
2 in.	5.08 cm.	4 cm.	$1\frac{9}{16}$ in.
3 in.	7.62 cm.	5 cm.	$1\frac{15}{16}$ in.
4 in.	10.2 cm.	6 cm.	$2\frac{3}{8}$ in.
5 in.	12.7 cm.	7 cm.	$2\frac{3}{4}$ in.
6 in.	15.2 cm.	8 cm.	$3\frac{1}{8}$ in.
7 in.	17.8 cm.	9 cm.	$3\frac{1}{2}$ in.
8 in.	20.3 cm.	10 cm.	$3\frac{15}{16}$ in.
9 in.	22.9 cm.	12 cm.	$4\frac{3}{4}$ in.
10 in.	25.4 cm.	15 cm.	$5\frac{7}{8}$ in.
11 in.	27.9 cm.	20 cm.	$7\frac{7}{8}$ in.
1 ft.	30.5 cm.	25 cm.	$9\frac{13}{16}$ in.
2 ft.	61.0 cm.	30 cm.	$11\frac{1}{4}$ in.
3 ft.	91.4 cm.	40 cm.	$15\frac{3}{4}$ in.
4 ft.	1.22 m.	50 cm.	$19\frac{3}{4}$ in.
5 ft.	1.52 m.	60 cm.	$23\frac{5}{8}$ in.
6 ft.	1.83 m.	80 cm.	$31\frac{1}{2}$ in.
7 ft.	2.13 m.	100 cm.	$39\frac{1}{2}$ in.
8 ft.	2.44 m.	1.5 m.	4 ft. 11 in.
9 ft.	2.74 m.	2 m.	6 ft. 7 in.
10 ft.	3.05 m.	2.5 m.	8 ft. 3 in.
15 ft.	4.57 m.	3 m.	9 ft. 10 in.
20 ft.	6.10 m.	4 m.	13 ft. 2 in.
30 ft.	9.14 m.	5 m.	16 ft. 5 in.
40 ft.	12.20 m.	10 m.	33 ft. 0 in.
50 ft.	15.24 m.	15 m.	49 ft. 2 in.
100 ft.	30.48 m.	20 m.	66 ft. 0 in.

Some items of equipment or certain materials mentioned in this book may not be freely available in every country. Import and marketing conditions vary widely and are outside the control of the photographic retailer.

## HOW TO . . .

- Load the Retina Reflex: 15**
- Hold the Retina Reflex: 16**
- Shoot with the Retina Reflex: 18**
- Unload the Retina Reflex: 20**
- Focus the Retina Reflex: 12**
- Expose with the Retina Reflex: 18, 70**
- Choose the Stop: 18, 70**
- Use the Shutter: 9**
- Use the films: 25**
- Use colour film: 50**
- Use the finder: 12**
- Use the filters: 76**
- Use the lens hood: 9**
- Use flash: 88**
- Use the interchangeable lenses: 53**
- Make close-ups: 79**

## WHAT IS WHERE?

- Body release: 18
- Cable release: 10
- Carrying: 18
- Cassette: 25
- Close-ups: 79
- Copying stand: 84
- Cutting film parts: 20
- Depth of field: 54, 59
- Diaphragm: 8, 59
- Distance setting: 12, 18
- Double exposures: 24
- Exposure: 70
- Exposure meter: 70
- Films: 25
- Film handling: 25
- Film release: 20
- Filters: 76
- Finder: 12
- Flash: 88
- Focusing: 12, 59
- Frame finder: 14
- Gradation: 50
- Grain: 30
- Interchangeable lenses: 53
- Latitude: 50
- Lenses: 6, 53
- Lens Hood: 9
- Loading: 15
- Loading cassettes: 29
- Micro-attachment: 84
- Polarizing filter: 78
- Refills: 25
- Releasing: 18
- Re-winding: 20
- Safelight: 25
- Shooting: 18
- Shutter: 9
- Stereo attachment: 84
- Supplementary lenses: 79
- Trimming film: 25
- Unloading: 20
- Zone focusing: 56, 62





## FOCAL CAMERA GUIDES

Asahi Pentax Guide	65p	Miranda Sensorex Guide	75p
Bolex H8-H16 Guide	75p	Movikon Guide	40p
Bolex 8 mm. Guide	65p	Nikkormat Guide	75p
Brownie Movie Guide	55p	Nikon F Guide	75p
Canonet Guide	65p	Optima Guide	55p
Canon Reflex	75p	Praktica Guide	75p
Contaflex Guide	70p	Retina Guide	60p
Contax Guide	65p	Retina Reflex Guide	60p
Edixa Reflex Guide	55p	Retinette Guide	75p
Exakta 35 mm. Guide	65p	Robot Guide	40p
G.B.-B. & H.624 Guide	55p	Rollei 35 Guide	65p
Hasselblad Guide	65p	Rolleicord Guide	65p
Ilford Elmo Guide	55p	Rolleiflex Guide	75p
Isolette Guide	40p	Sportsman & Sportsmaster Guide	55p
Karat Guide	25p	Sportster & Viceroy Guide	40p
Konica Guide	70p	Vito Guide	55p
Leica Guide	95p	Vitomatic Guide	55p
Leicaflex Guide	75p	Yashica Guide	65p
Mamiya Sekor SLR Guide	70p	Yashica 35 mm. Guide	65p
Minolta SR Guide	75p		
Minox Guide	65p		

The British Journal of Photography, London, about  
Focal Camera Guides:

*“There are guides and guides. It is rather appalling to be handed a tome of some thousand pages . . . . Well, that is not the Focal Press way. That comprises a little book which first tells you all about your particular camera . . . warns you how to treat it properly, how to hold it, just how to expose the film, what film to buy, tells you all you want to know, for a start, about focusing, discusses the proper use of filters and of flash, and explains the several characteristics of the subjects that you may choose to photograph . . . . And all that for a few shillings.”*