

NOVEMBER 1965

NO. 768555

Servicing the

KODAK RETINA II F CAMERA



EASTMAN KODAK COMPANY
Apparatus Service Department
ROCHESTER, NEW YORK 14650

TABLE OF CONTENTS
KODAK RETINA II F CAMERA

	<u>PAGE</u>
I. <u>FILM TRANSPORT</u>	
SPECIFICATIONS -----	3
SERVICE HINTS -----	4
II. <u>RANGEFINDER</u>	
SPECIFICATIONS -----	5
SERVICE HINTS -----	5-6
III. <u>EXPOSURE METER</u>	
SPECIFICATIONS -----	7
SERVICE HINTS -----	7-10
IV. <u>HOUSING</u>	
SPECIFICATIONS -----	11
SERVICE HINTS -----	11-12
V. <u>SHUTTER</u>	
SPECIFICATIONS -----	13
SERVICE HINTS -----	13-15
<u>USEFUL TOOLS, LUBRICANTS, AND CEMENTS</u> -----	15

I. FILM TRANSPORT

SPECIFICATIONS

1. Rewind knob should:
 - a) Be extended upward approximately 5/16" above top housing, when rotated slightly in a counterclockwise direction.
 - b) Be locked flush with top housing, when depressed and rotated slightly in a clockwise direction.
2. Rewind post assembly should rotate in both directions with a minimum of resistance.
3. Film type indicator (on knob) should rotate with resistance sufficient to prevent accidental movement during normal use.
4. Film advance lever should:
 - a) Set shutter.
 - b) Rotate sprocket and take-up spool. (Clutch assembly should have sufficient torque to take-up film.)
 - c) Advance exposure counter one mark at end of stroke. Tolerance: $\pm 1/3$ of a division.
 - d) Be free of binds or rough action.
 - e) Return to original position by spring action and be locked until exposure release is actuated.
 - f) Be locked when exposure counter is on the #1 position.
5. Exposure release actuation should:
 - a) Be free of binds and have spring tension sufficient to return to up position.
 - b) Release film transport mechanism slightly before release of shutter.
 - c) Have a slight amount of over-travel after release of shutter.
6. Counter advance button should:
 - a) Be free of binds and have sufficient spring tension to return button toward advance lever.
 - b) When actuated, move the dial a maximum of two divisions and unlock advance lever when dial is at #1 position.
7. Rewind clutch button should:
 - a) Be secure and have spring tension.
 - b) When depressed, release the film transport for rewinding of film.
 - c) Remain in the depressed position until released on first actuation of film advance lever.
8. Pressure pad, back frame, film rails and film roller should be free of imperfections which can damage film.
9. Camera should wind and rewind film smoothly.

1. FILM TRANSPORT

SERVICE HINTS

Service requirements to the film transport will be similar to those encountered in *RETINA AUTOMATIC III* Cameras. Basic difference is the exposure counter mechanism, which is located on the bottom of the case and is about identical with that used on the *RETINA REFLEX III*.

10. Rewind Assembly

10.1 Knob unscrews from post in same manner as previous models.

10.2 The lubricant used on the post and bearing is important. Do not use petroleum base lubricants; they will destroy the plastic. A plastic lubricant such as A&O 60-3354 or A&O 61-3663 is recommended.

11. Erratic or chronic overlapping of negatives is generally caused by an excess of heavy grease on the N5421 Wind Shaft Pawl and its driving area. If trouble of this type is encountered, the area should be thoroughly cleaned and relubricated as follows:

- a) Lubricate inner bearing surfaces of N5418 Gear sparingly with 61-3627 Grease.
- b) Lubricate with dry graphite or dry molycote the balance of the area and the components.
- c) Care should be used in assembling the pawl; the squared corner should engage the gear. If the rounded corner engages, it can cause failure to advance film.

12. Install wind shaft as shown and pretension by rotating lug "A" clockwise one full revolution. Then fit balance of components.

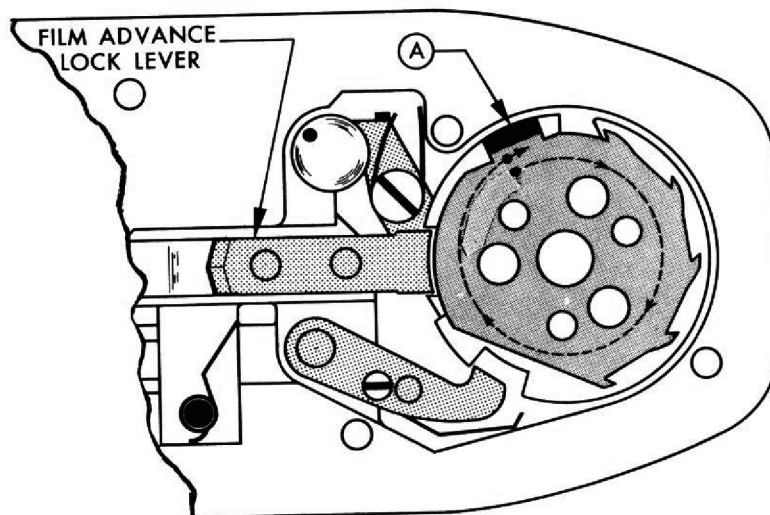

II. RANGEFINDER

SPECIFICATIONS

13. Taking lens should be focused accurately on an object 15 feet from film plane (approximately the top rear edge of top housing) with a ground glass on back frame (ground side in).
14. Focus mount should be free of excessive binds or looseness. Slight variations in torque required on an individual camera are permissible provided the action is smooth and has sufficient resistance to prevent accidental movement during normal use.
15. Movable image in "bright image" area should be in focus.
16. Maximum permissible rangefinder scale error either side of the stationary index mark is 1/2 the distance of the f/2.8 index (first dot on each side of stationary index) of the depth of field scale.
17. Coincidence of an object at infinity (minimum distance of 500 feet) should occur when focus ring reaches the infinity stop.
18. There should be no lag or lost motion of the movable image when the focus ring is moved off the infinity position.
19. There should be no binding or hesitation of the movable image when the focusing ring is rotated through its full range in both directions.
20. Stationary and movable images of horizontal lines should be superimposed.
21. Stationary and movable images of vertical lines should be parallel.

SERVICE HINTS

22. Removal of Range Finder.

To avoid damage to the exposure meter needle which extends into the assembly, lift in a vertical direction until the needle is cleared.

23. Lens Focus

To focus lens, remove N6436 Retainer with Tool #1019 or #1091 to allow access to the focus ring clamping screws. If the maximum possible sharpness is not obtained on either side of the ground glass, the misalignment can be corrected by placing N4242 Washers as required between the front mount plate and the case.

24. Adjustments

24.1 Bright Image Focus

Focus of the movable image in the center bright circle is controlled by loosening N4958 Screw and sliding N6383 Mount Assembly to the right or left.

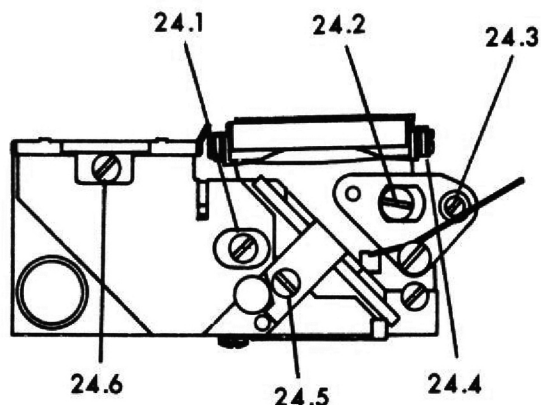

II. RANGEFINDER

SERVICE HINTS (continued)

24. Adjustments

24.2 Footage Adjustment at Infinity

Set lens at infinity and observe an object at a distance of at least 500 feet. Adjust eccentric (24.2) as required or until images coincide.

24.3 Footage Adjustment at 3.5 Feet

Set lens focus at 3.5 and observe an object 3.5 feet from film plane (rear of top housing) of the camera. Adjust eccentric (24.3) as required or until images coincide.

Recheck infinity adjustment (24.2) and adjust as required. Recheck 3.5 feet (24.3) and adjust as required. Repeat checks and adjustments until both settings are correct.

24.4 In severe cases of misalignment, a slight sideways adjustment (24.4) either to the right or left of the movable lens N6394 and its mount will correct the condition. To make this adjustment, it will be necessary to remove the finder assembly (refer to instruction 21) and loosen the screws holding the lens assembly to the movable arm.

24.5 Horizontal (Halving) Adjusting

Adjustment is controlled by shifting the position of the beam splitter.

24.6. Finder Alignment

Finder Alignment can be checked and adjusted using the #984 Finder Alignment Chart which was originally designed for the *KODAK SIGNET 30* and *50* Cameras or by comparing the finder image with the ground glass image at a subject distance of at least 65 feet.

The following method is suggested for the #984 Chart.

- a) Attach an N-1 *KODAK* Auxiliary Lens (N3313) to the camera lens and set focus ring at the 6-foot index.
- b) Position the camera on a secure support with the film plane parallel to and approximately 25 1/4 inches from the chart.
- c) Set shutter at f/2.8 and "B" and open shutter.
- d) Place a ground glass on the camera back frame and align back frame with the small dashed line of the chart.
- e) Observe finder image; the luminous frame lines of the finder should fall outside the area defined by the staggered block outline.
- f) Adjustment in a horizontal plane is controlled by sliding the N6387 Frame Support to the right or left. Adjustment in a vertical plane is controlled by inserting or removing spacers N5352, N5353, or N5354 between the frame support and the finder body.

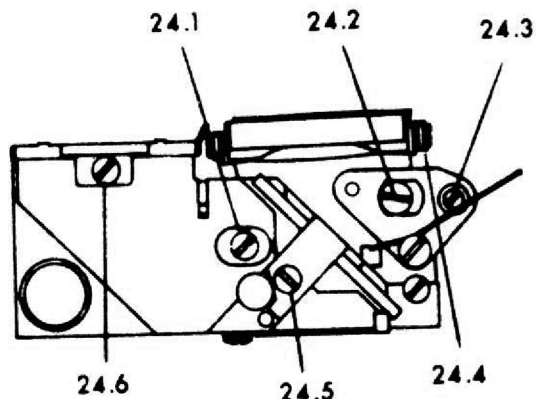

III. EXPOSURE METER

SPECIFICATIONS

25. Rotation of either the speed ring or diaphragm ring should actuate meter needle in finder.
26. Diaphragm ring should indicate $f/5.6 \pm 3/4$ stop when meter needle is centered within triangular lines at base of finder and shutter is set at ASA 25 and 1/125 second and meter cell is exposed to a light source of 565 foot-Lamberts (Tool #991 set at 100 volts).
27. Meter needle should:
 - 27.1 Be free of binds and sticking.
 - 27.2 Be vertical when centered within the triangular lines.
28. Needle Adjustment

Control of the meter needle is confined only to the Initial Adjustment (Inst. 31) and Final Adjustment (Inst. 34).

The potentiometer located at the rear of the exposure meter cell is adjusted by the manufacturer of the meter. It is used only for matching cells and meter bodies at an unknown light level.

NOTE: DO NOT CHANGE THIS SETTING.

SERVICE HINTS

29. Disassembly
 - 29.1 Remove top housing and unsolder the two wires to the flash socket assembly.

NOTE: Red wire from small lead on socket, white wire from large lead on socket.
 - 29.2 Remove shutter assembly using Tool #1132 and disconnect flash lead. Then lift out range finder actuating pin.
 - 29.3 Remove finder and range finder assembly.

NOTE: Lift in a vertical direction to avoid damage to meter needle.
 - 29.4 Remove N6402 Front Cap Assembly (3 screws).

NOTE: Use caution, N6057 Insulating Pin in flash terminal can be easily lost.
 - 29.5 Remove N6401 Frame (black plastic).
 - 29.6 Remove strap brackets, top panel and meter cell retainer screw.
 - 29.7 Remove N6090 Screws (2-brass), N6412 Support Plate, washers and N6410 Scanning Pin Assembly.
 - 29.8 Remove front retainer screws and separate front assembly from case.

III. EXPOSURE METER

SERVICE HINTS (continued)

30. Reassembly with Adjustments

30.1 To facilitate reassembly and maintain engagement of shutter release assembly, a small bracket can be made as shown in the following sketch. This should be attached to the top of camera case, using any suitable screw and the threaded hole for attaching the meter cell.

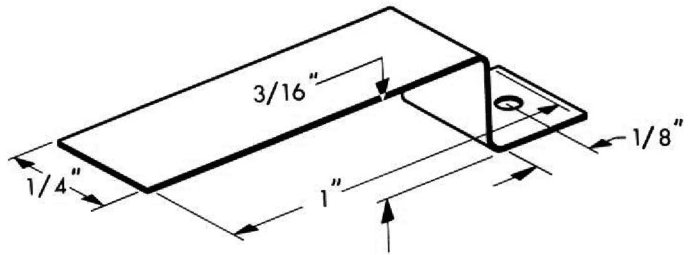

Position release assembly on its guide post and be sure the film wind release shaft is engaged, then swing bracket over top of release to hold in a depressed position during assembly of front to case.

- 30.2 Lubricate both ends of N5361 Shutter Cocking Shaft with Grease (A&O 61-3627) and insert in case.
- 30.3 Assemble meter to front plate, securely tighten screws and position wire leads under tape at bottom of front plate.

30.4 Position N6417 Setting Coupler as shown before installation if the setting rack is in camera. If the setting rack is to be fitted later, the engagement with the shutter setting shaft is immaterial, since it can be set at this position when installing the rack.

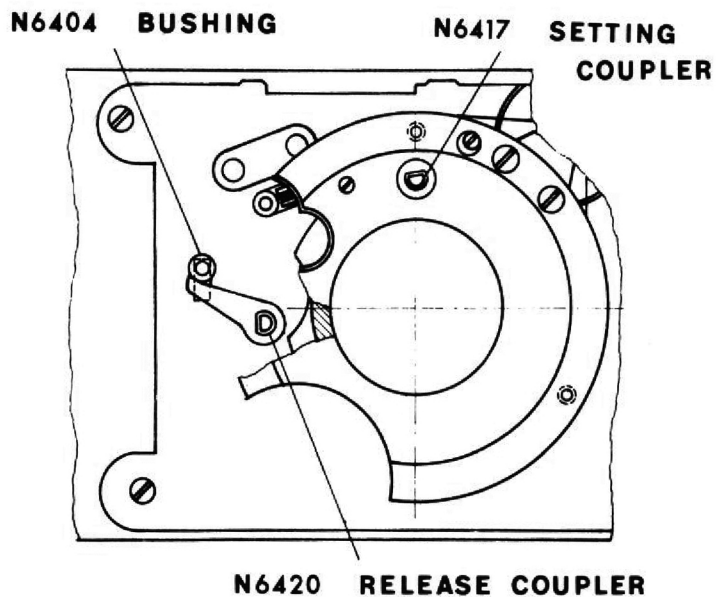

Be sure N6420 Release Coupler is below the point where N6404 Bushing fits on the pin of the release shaft assembly.

- 30.5 Install front assembly, fitting leads to cell into slot of case. Replace screws (4) and tighten securely.
- 30.6 Remove bracket (Inst. 30.1) and fit top frame, strap brackets, meter cell and front frame.

III. EXPOSURE METER

- 30.7 Wind N6411 Retaining Cord in a clockwise direction as shown and attach spring.

Be sure cord is on the inside of the lug.

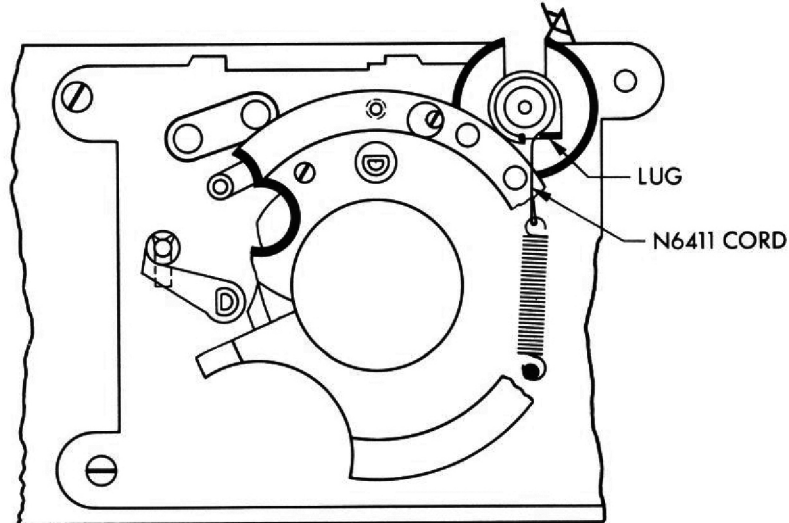

- 30.8 Install N6410 Scanning Pin Assembly and lead chain around hub in a counter-clockwise direction as shown. Then replace washers and support plate.

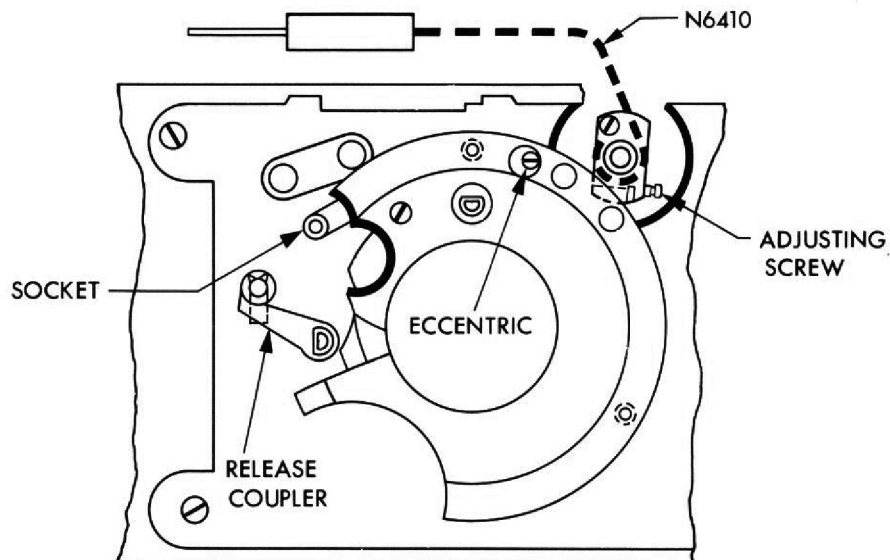

- 30.9 Lead chain over eccentric adjustment roller and insert pin into socket.

NOTE: Chain must be free of kinks and have only a 90° twist as it is positioned over roller assembly at the socket.

Hold in position, locate release coupler as shown above and replace N6402 Front Cap Assembly with N6057 Insulating Pin in flash terminal.

NOTE: N6057 Pin can be lubricated very sparingly with a silicone grease (A&O 60-3354 or A&O 61-3663) to hold it in place while fitting cap.

III. EXPOSURE METER

SERVICE HINTS (continued)

31. Initial Adjustment

Install Tool #1122 on front and set securely as shown in figure 1 and adjust eccentric to position second tooth of meter in alignment with the index mark as shown in figure 2.

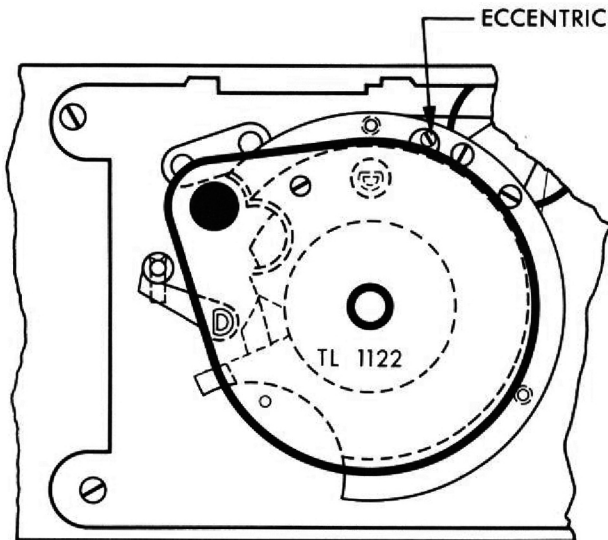

FIGURE 1

INDEX MARK AND SECOND TOOTH

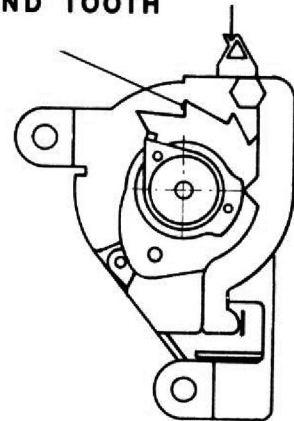

FIGURE 2

32. Position N6417 Setting Coupler and N6420 Release Coupler as shown in Inst. 30.4 and replace range finder actuating pin.
33. Reconnect flash contact lead and replace shutter assembly.
34. Final Adjustment
If the exposure meter does not meet Specification #26 adjust as follows:
NOTE: It is not necessary that the finder assembly be replaced since the needle and triangle are readily visible.
 - 34.1 Remove name plate at upper corner of front cap assembly.
 - 34.2 Rotate speed ring to allow access to the adjustment screw on the scanning pin assembly (meter end).
 - 34.3 Using a suitable tool (second screwdriver or probe) prevent the rotation of the hub and change adjustment at this point. (See sketch in Inst. 30.8 for location of screw.) Recheck for specification and balance out any excess movement of needle when diaphragm ring is rotated in either direction.
 - 34.4 Reseal adjustment screw after adjustment.
35. Replace finder assembly and make appropriate range finder adjustments if required.
36. Refasten flash leads to flash socket (red wire to small lead on socket and white wire to large lead on socket).
37. Replace balance of components.

IV. HOUSING

SPECIFICATIONS

38. Back release button guard should operate with a minimum of force and return by spring action.
39. Back latch should operate with a minimum of force and return by spring action.
40. Back should fit case with a minimum of interference, latch securely and open partially under film pad pressure when latch is depressed.
41. Reflector cover should:
 - a) Be retained securely in a closed position.
 - b) Spring open fully when release button is actuated.
 - c) Not require excessive force to close and latch.
42. Lamp socket should:
 - a) Accept AG-1 lamps.
 - b) Release lamps when release button is actuated.
43. Reflector and lamp release button should operate with a minimum of force and return by spring action.
44. Battery cover should:
 - a) Fit base of camera securely.
 - b) Make satisfactory electrical contact with battery.
45. Flash circuit to lamp socket (on top housing) should be broken when a cord (from separate flashholder) is inserted in flash terminal on front.
46. Either accessory flash terminal (on front) or built-in flash system (on top housing) should be capable of firing a flash lamp.

SERVICE HINTS

47. Battery Testing

Batteries supplied with this camera (PX 13 or 625) should be tested for voltage with an appropriate meter. Fresh batteries should give a voltage reading of approximately 1.35 volts. Batteries testing 1.0 volt should be replaced since the recharging rate of the flash system can become excessively long and result in flash complaints.

The Aerotron Battery Tester, Model 411 cannot be used successfully because of the built-in resistance.

48. Test Lamp #762038

This is a special test lamp for use only on the *KODAK RETINA IIF* Camera. Test Lamp #761743 cannot be used for testing because of its filament resistance.

IV. HOUSING

SERVICE HINTS (continued)

49. Testing

49.1 Complete Camera

- a) Check battery voltage; if 1 volt or less replace battery.
- b) Insert Test Lamp #762038 in socket, set shutter at 1/30 second.
- c) Trip shutter, test lamp should light.

NOTE: In testing repeatability, a pause of at least 5 seconds should occur between actuations to allow unit to recharge fully.

49.2 Flash Unit with Top Housing.

Testing this assembly (or the flash unit only) will require the use of a battery which tests at least 1 volt. Attach a wire lead with a small alligator clip to the (+) side of battery.

- a) Attach alligator clip (+) to the small lead of flash unit and hold (-) side of battery in contact with top housing.
- b) Insert Test Lamp 762038 in socket.

NOTE: Be sure lamp contacts of socket do not contact the alligator clip.

- c) To flash lamp, use an appropriate tool to short large lead of socket assembly to top housing, alligator clip or the rear lamp contact.

49.3 Flash Unit Only

- a) Attach alligator clip (+) to small lead of flash unit and hold (-) side of battery in contact with contact on top of unit.
- b) Insert Test Lamp 762038 in socket.
- c) To flash lamp, use an appropriate tool to short large lead on alligator clip to the rear lamp contact.

49.4 Continuity in Camera

- a) Insert a satisfactory battery in camera.
- b) Remove top housing and disconnect leads from flash unit.
- c) Hold one contact of Test Lamp 762038 in contact with case and then touch red lead (from (+) side of battery) to the other lamp contact. Test lamp should barely glow.

50. Flash Unit

No service work of any type can be performed on this unit. If flash failure is encountered (Inst. 49.2 or 49.3) the unit must be replaced. However, the cause can also be in the shutter or in any of the connections between the components.

V. SHUTTER

SPECIFICATIONS

51. Shutter speed should be within the following total time tolerances:

1 second	800-1200 milliseconds	1/30 second	26-39 milliseconds
1/2 "	400-600 "	1/60 "	13-20 "
1/4 "	200-300 "	1/125 "	7-11 "
1/8 "	100-150 "	1/250 "	3.5-7 "
1/15 "	51-76 "	1/500 "	2.5-5 "

52. Flash synchronization - X contact

53. Contact efficiency - 75%

54. Diaphragm ring should:

- a) Operate smoothly.
- b) Actuate diaphragm blades and meter needle.

55. Speed ring should:

- a) Operate smoothly with detent action at each speed index.
- b) Actuate meter needle.

56. Self-timer lever should:

- a) Operate with or without setting shutter.
- b) Be free of binds and not require excessive force to set.

57. Self-timer should operate for 8 to 10 seconds.

58. ASA ring should:

- a) Operate smoothly when unlocked.
- b) Be locked at any setting upon release of lock lever.

59. Shutter blades should be free of grease, oil or rust spots.

SERVICE HINTS

Certain repairs to the shutter, other than to the shutter blades or diaphragm blades, can be performed without removal of the shutter assembly from the camera.

60. Shutter and/or Diaphragm Blades

Repairs to any blades will require removal of the shutter and complete disassembly. The following procedure is recommended.

61. Disassembly

- 61.1 Remove shutter.
- 61.2 Disassemble front of shutter, removing all components except the front tube, bulb lever and release lever.
- 61.3 Turn shutter over and remove all components on the rear of shutter.
- 61.4 Open shutter and diaphragm blades, then remove case to mechanism plate screws, and case.

V. SHUTTER

SERVICE HINTS (continued)

62. Reassembly

- 62.1 Examine mechanism plate for loose blade studs. If loose, remove front tube and operating ring and retighten. If studs are missing, the mechanism plate must be replaced.
- 62.2 Position blade operating ring in the blade-open position and orient mechanism plate as shown to install brass spacer and blades.

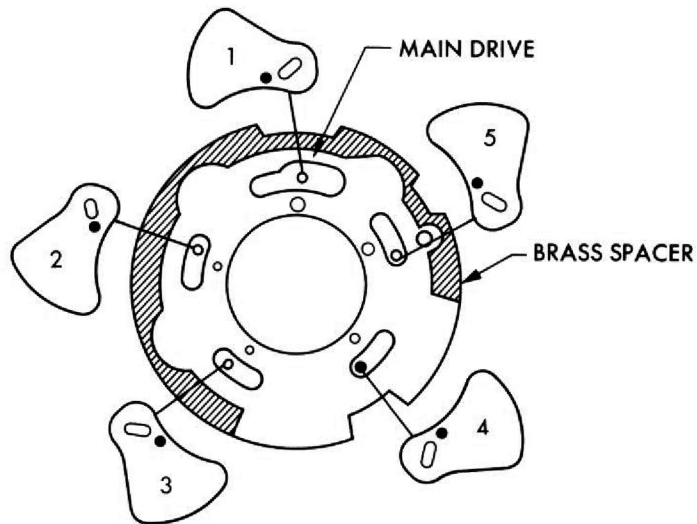

REAR VIEW OF MECHANISM

- 62.3 Install diaphragm plate and blades as shown.

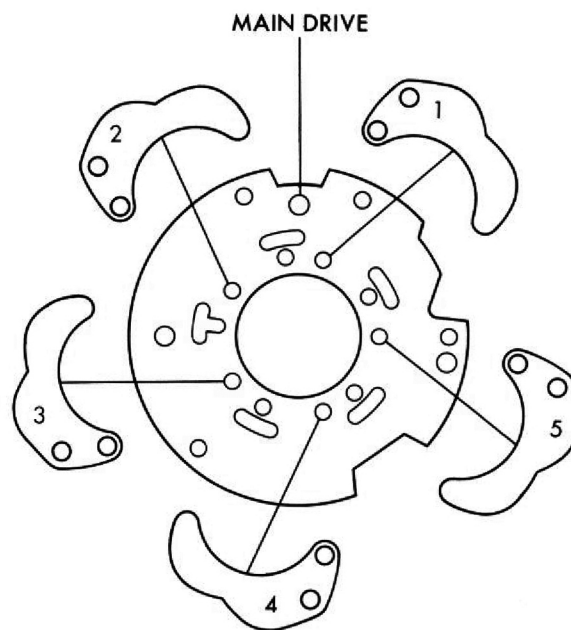

REAR VIEW OF DIAPHRAGM PLATE

V. SHUTTER

62.4 Install diaphragm operating plate as shown and replace case.

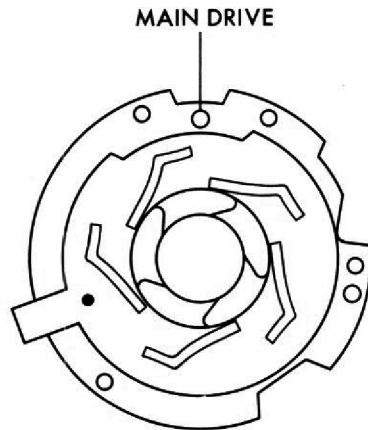

REAR VIEW OF DIAPHRAGM ACTUATING PLATE

62.5 Replace balance of components; check and adjust speeds and flash contact as required; refit shutter to case.

USEFUL SPECIAL TOOLS

#249	Bit-Wind Shaft Gear (Use with #30 Screw Driver)
#518	Wrench-Rewind Release Button
#592	Bit-Rewind Knob Screw (Use with #30 Screw Driver)
#984	Finder Alignment Chart
#1019	Wrench for Lens Washer (#1091 can be substituted)
#1122	Fixture-Initial Adjustment of Meter
#1132	Bit-Shutter Retaining Collar (Use with #650 Handle)
#762038	Test Lamp

RECOMMENDED LUBRICANTS

A&O 60-3354	
or	
A&O 61-3662	- Rewind Assembly grease (Silicone)
A&O 61-3627	- Rack, Various Bearings, Wind Shaft and Setting Shaft
A&O 61-3778	- Dry Molycote - Wind Pawl and Various Surfaces require a dry lubricant.

RECOMMENDED CEMENTS

Vulculac Cement	- Covering
Lacquer	- Motor Adjustment Screw
	Wind Shaft Gear Screw

Kodak