



*At Home with the*  
**Kodak**



*At Home with the*

*Kodak*

EASTMAN KODAK COMPANY

ROCHESTER, N. Y.     *The Kodak City*

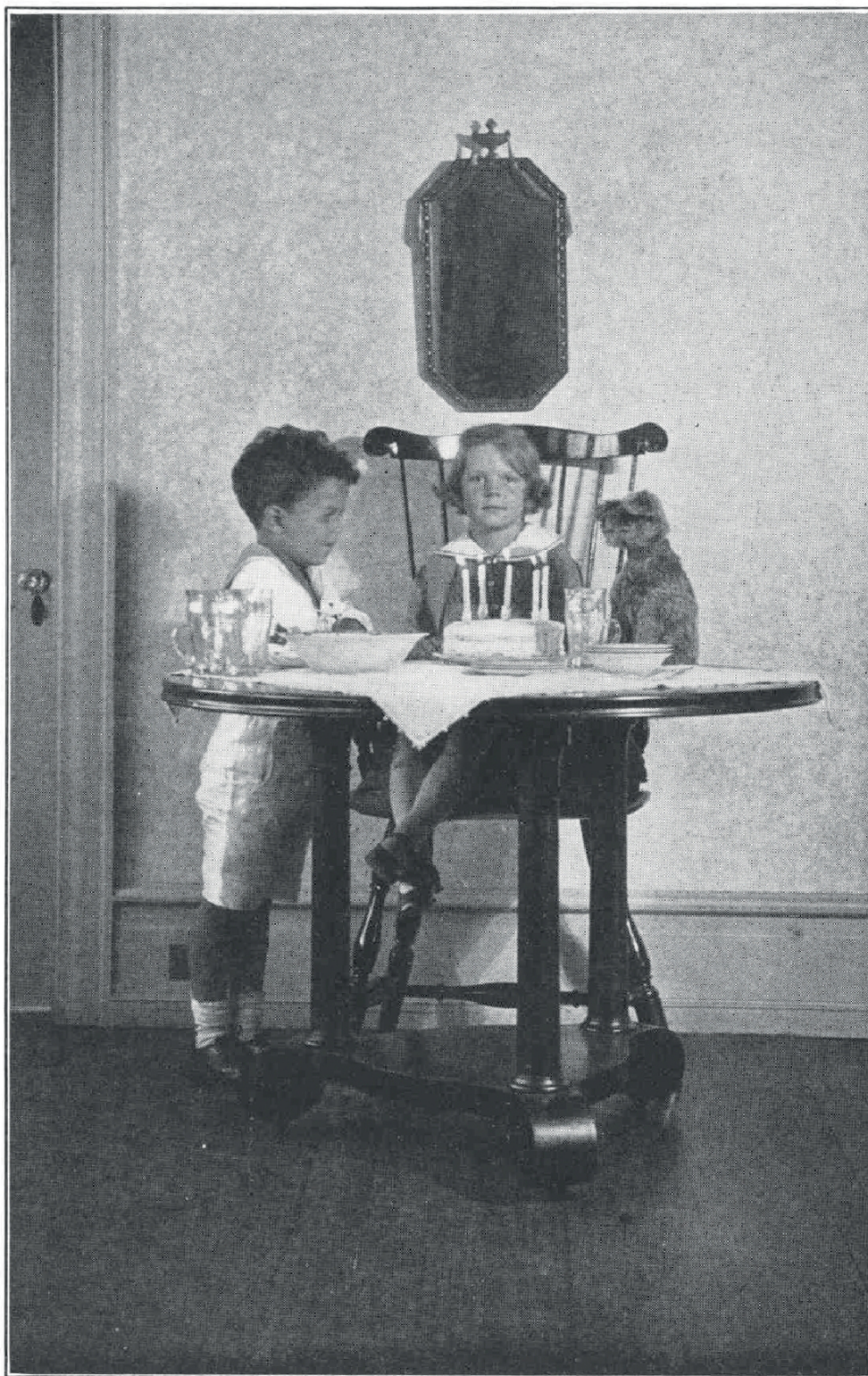

*An Exclusive Party*

Enlarged from Negative made with 1A Pocket Kodak Series II with  
Kodak Anastigmat Lens *f.7.7*

# At Home with the Kodak

## *The Story of Us*

How Mary Josephine has changed in the last year! It seems like yesterday that she was using baby prattle—and, by a seeming day after tomorrow, she will be having her hair done up.

It is only when we look over the old Kodak album—or albums, rather—that we realize the changes and the importance of



*Sis.*

A Brownie Snapshot

filling the new ones. There's Dick, chubby and rosy, as he trudged off for his first day of school, full of a strange excitement and importance. And here he is again—a broad-shouldered husky who, on last Saturday, dodged down the field for a touchdown that brought ten thousand roaring maniacs to their feet. How it fuses him when we prove by the old Kodak negative with the autographic date that he was "such a cute little angel" at seven.

How comfortably grandmother grew old and how beautifully the pictures show it. There she is by the window with her knitting, smiling at the present, but somehow you know, as you look at the serene face, that she is living in the past.

And even the house; how the vines have improved it. We must have another picture; it looks more like a new home now. And could you believe it, the way those maples have grown in just a few years? That picture reminds me that when they were first set out, Dad used to call our street the Avenue de Bean Pole.

Nimrod, you lazy old rascal, get away from that fireplace long enough to come over here and see what a disreputable pup you were. Here you are, caught in the very act of shaking all the sawdust out of Mary Josephine's new doll. No—you won't move? I suspect from the look beneath your uplifted eyebrows that you are only interested in that thumb-worn old hunting album of Dad's.

These intimate pictures—thanks to the family Kodak and Dick's Brownie—were fun in the making. There was an eager joy when the finished prints came home, but *now they are priceless*. They are a record because they tell the truth and because the autographic dates and titles on the negatives are indisputable. But they are more than a record. Each album is a chapter in a story, to us the most fascinating of all stories—*the story of us*.

## Making the Pictures

The purpose of this little book is to help the reader in the making of those entertaining pictures of friends, and family, and home, that make a Kodak album a picture-diary of endless interest. The Kodak way of making pictures is so simple that anyone can make them after reading the brief instructions that are contained in the manuals which accompany every camera. But there is a lot more fun in photography than just "pressing the button"—and much of it lies in planning the pictures before they are made. Here is the chance for artistry, ingenuity and technique, and in this little book are suggested some of the ways in which very delightful home pictures may be made. Actual photographs are reproduced and explanations given of how they were planned and taken. All of them were made on Kodak film with either a Kodak or a Brownie, as indicated.



*The Junior Partner*

Made with a 3A Special Kodak by Mrs. H. D. Eaton

## Indoor Portraits by Daylight

Portraits can be made by daylight in any room that has a window through which the unobstructed light from the sky can enter.

An excellent portrait lighting can be obtained by drawing down the shades on all but one of the windows, and then placing the subject a few feet from the window through which the light is coming, in the position shown in the diagram below.

When a subject, placed in the position S, looks squarely at a camera that is at position C, the light will fully illuminate the side of the face that is nearest to the window, and it will also illuminate, with almost equal brightness, a part of the cheek on the other side of the face.

The lighting effect thus obtained can be seen by standing directly in front of the camera. We should now observe the shadow cast by the nose. If this shadow extends downwards and sideways, the lighting will prove satisfactory, for it will give the desired effect of roundness to the face. If, however, the shadow extends sideways only, the light is coming too much from the side and too little from the top. Such a lighting will make the face look flat. To remedy this difficulty the lower half of the window should be covered with a sheet or with a piece of muslin, so as to cut off some of the side light and thus make the light come downward at about a 45 degree angle.

A sheet of white cloth or white paper, three feet square or larger, should now be placed at position R (see Diagram 1)

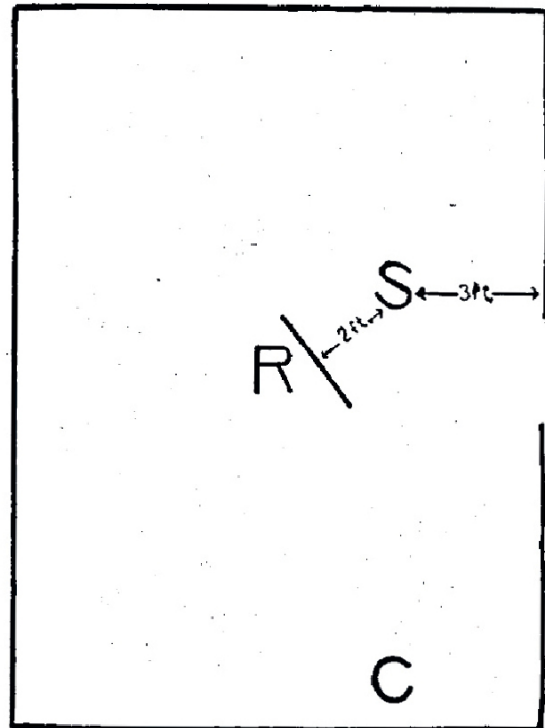

Diagram 1  
S-Subject    C-Camera    R-Reflector



*A Close-up*

Made with a  
3A Kodak and  
Kodak Portrait Attachment

Exposure:  
3 seconds. Stop 8



*Babe*

Made with a 3A Special Kodak  
by J. A. Willard  
3:40 P. M., November.  $\frac{1}{2}$  Second,  $f.6.3$

nated than the depression between the high part of the cheek and the nose. The angle at which the reflector should be placed is shown in Diagram 1.

The lighting we have described is similar to those used for making the pictures on pages 2, 7 and 18.

The subject of the portrait on this page was sitting on a window seat. The reflector that helped to illuminate the shadow side of the face was a large piece of white paper which

for reflecting light to the shadow side of the face. The reflector may be held by an assistant or may be supported on two T-shaped sticks, which can be tied to the back of a chair.

The angle at which the reflector faces the subject is important, for it should reflect light to the front as well as to the side of the face. If it reflects light to the side of the face only, the lighting will not be pleasing, for the ear on the shadow side will be more brightly illumi-

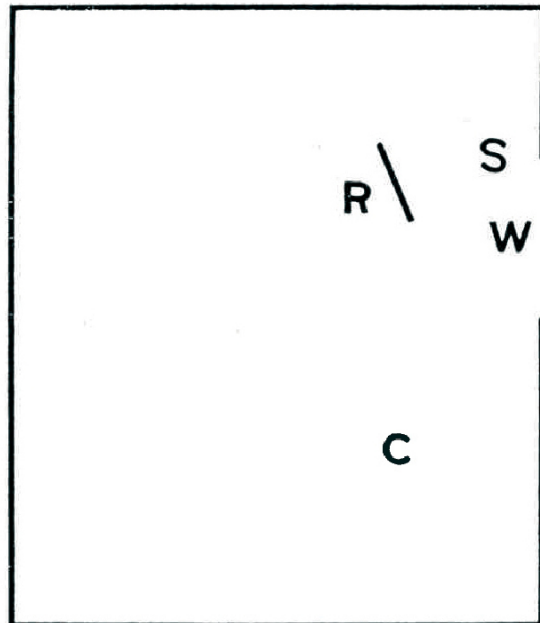

Diagram 2  
S-Subject      C-Camera  
R-Reflector    W-Window



*The Social Secretary*  
 Made with a 2C Kodak Jr., by Elizabeth T. Lilly

was hung over the back of a chair. Diagram 2 shows how similar pictures can be made.

Diagram 3 shows the positions that subject, camera and reflector should occupy in relation to the window in order to

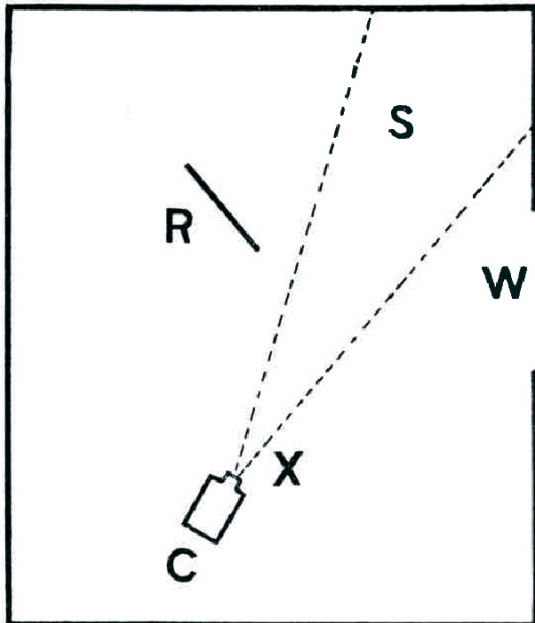

Diagram 3  
 S-Subject    C-Camera    R-Reflector  
 W-Window    X-Position for placing  
 a shade for lens

secure a lighting effect similar to that shown in the picture above.

Diagram 4 shows that this same lighting was used for making the picture on page 10.

In using this lighting it is necessary to prevent as much as possible of the strong light, that is not reflected from the subject, from entering the lens and impairing the brilliancy of the picture. This can be done by holding a piece of cardboard between the lens and the win-



*Good Morning*

Made with a  
3A Special Kodak

Exposure 1/5 second  
f.6.3 Sunny day

dow (Diagram 3) a foot or more from the lens. The cardboard should be moved well out of the view of the finder. If it shows in the finder, it will show in the picture.

POSING. A portrait should be a good likeness. The less posing that is attempted the better the likeness is apt to be. It is, as a rule, better to "pose" the chair in which the subject is to sit than to induce the subject to assume any particular attitude or expression. In most cases the best portraits can be secured when people are permitted to assume their own characteristic attitudes.

The chair, in which the subject is to sit should not be placed squarely facing the camera. The seated figure should face diagonally to the camera and then, if a full front view of the face is desired, the head should be turned so that the nose will point directly toward the lens. Anyone who is seated can turn the head as suggested, without the slightest discomfort. This will avoid the square-shoulder effect which is usually unpleasing. In most cases, one shoulder should be more prominently shown than the other.

The effect of this can be seen in the pictures on pages 7 and 18. The square-shoulder effect is shown on page 3. While it is often pleasing in the case of full length portraits of children, it is not pleasing in head and shoulder portraits of large people.

**BACKGROUNDS.** The most appropriate backgrounds for portraits in the home are often furnished by the walls or draperies, when these do not contain conspicuous designs.

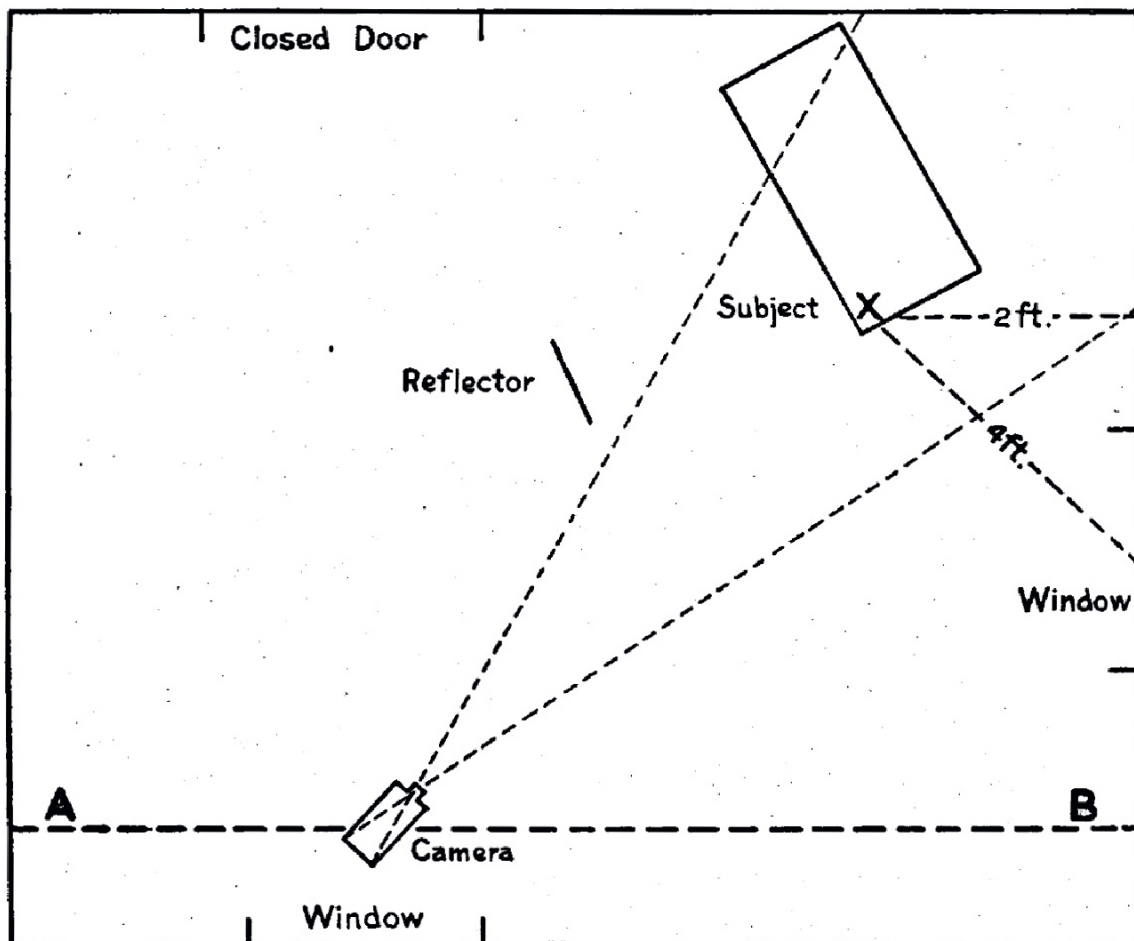

Diagram 4 showing arrangement of room in which the picture on the opposite page was made

Should plain backgrounds be preferred, any color of cloth that shows no pattern may be used. It should be placed not less than 3 feet behind the subject. The cloth should be free from wrinkles or creases which would show in the picture. It may be hung from the picture moulding or suspended in any other convenient way.

**EXPOSURE.** While portraits can be made indoors on sunny days with exposures as short as one-fifth second, when an *f.6.3* lens is used, and the subject is not more than 3 feet from the window, it is always best to give a more ample exposure when it is possible to do so. On bright days the exposures recommended, when rectilinear or anastigmat lenses are used with the largest stop, are from 1 to 3 seconds. With single lens cameras the exposures should be from 2 to 6 seconds with the largest stop.

**TRIPOD.** Since indoor pictures must be made with time exposures, it is necessary to place the camera on a tripod, or some other rigid support, to prevent it from moving and blurring the picture while the exposure is being made.

## Portraits by Flashlight

The part of room that furnishes the most desirable setting for a portrait may receive so little light from the windows that it cannot be used for making portraits by daylight. The lighting problem can, however, nearly always be solved with flashlight.

By using an instantaneous flashlight we can make portraits, and also story-telling pictures, in a small fraction of a second. In fact, we can easily make flashlight pictures of the members of the family, engaged in their home pursuits, which could not be made by daylight, even close to a window, in any ordinary living room.

When flashlight pictures are rightly made they will look exactly like pictures made by daylight. The staring eyes that are sometimes seen in flashlight portraits are as unnecessary as they are objectionable. They are, in almost every case, the result of making the portraits in rooms that are too dark.



*Betty*  
*A Flashlight*

Flashlights can be made in the daytime as well as at night. If portraits are made in the daytime, when the outdoor light is very bright, the light in the room should, of course, be subdued by drawing down some of the window shades. If the outdoor light is dull the shades should not be drawn, for the room should always be well enough lighted so that everything in it can be plainly seen. When portraits are to be made at night all the lights in the room should be turned on.

Neither the subdued daylight nor the artificial light that is reflected from the sub-

ject and from the walls and furnishings will have any appreciable effect on the negative, provided the camera shutter is not opened until immediately before, and is closed again immediately after, the flash is made.

The picture above, and the one on page 14 were made in the daytime, with all the window shades left up. The one on this page was made with a 3A Kodak by the light of one No. 3 Eastman Flash Sheet. This was ignited in a Kodak Flash Sheet Holder which was

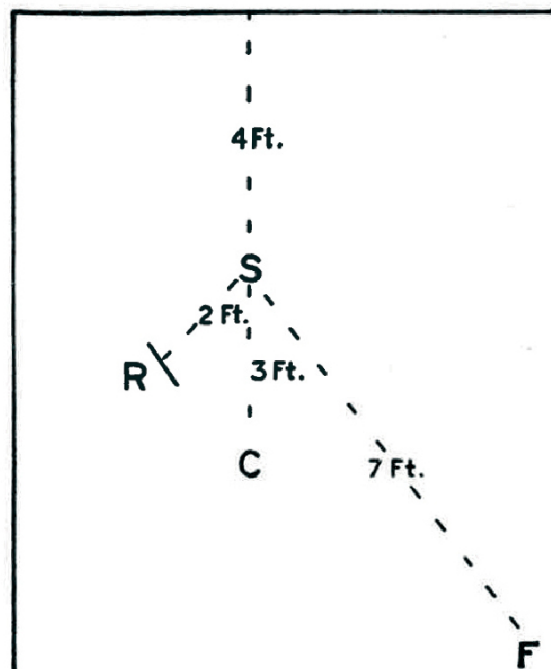

Diagram 5 showing how the portrait above was made S-Subject  
C-Camera F-Flashlight R-Reflector



*Jane*

Made by the light of one Eastman Spreader  
Flash Cartridge, see page 13

held 7 feet above the floor. Lens stop No. 8 was used and a Kodak Portrait Attachment (the use of which is explained on page 19) was placed in front of the lens. The position of the flash sheet in relation to the subject, and the distance the sheet was held from the subject, are shown in diagram 5 on page 13.

The staircase, shown in the picture on page 14, was 10 feet from the nearest window. This picture was made with a 3A camera (using lens stop No. 8) by the light of an Eastman Spreader Flash Cartridge. The flash was ignited 7 feet above the floor and 8 feet from the subject, at position F shown in diagram 6. A white muslin screen, about 3 feet square, was placed about a foot in front of the flashlight. This was used for diffusing, or softening, the light that passed through it.

The method adopted for securing this picture suggests one of the many ways that will induce young children to assume the position wanted when they are being photographed: The mother was at the top of the staircase calling to the child. As soon as the baby had reached the first step her father asked her where she was going. The camera shutter, which was set for a time exposure, was opened the instant she turned, then the flashlight was ignited and the shutter immediately closed.

Diagram 7 on page 17 shows how the story-telling picture on page 16 was made by the light of a No. 1 Eastman Flash Cartridge.

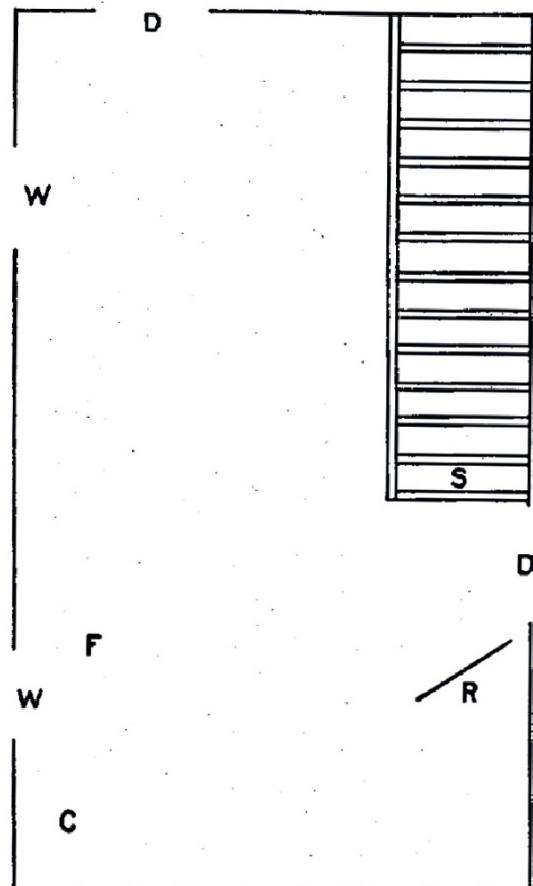
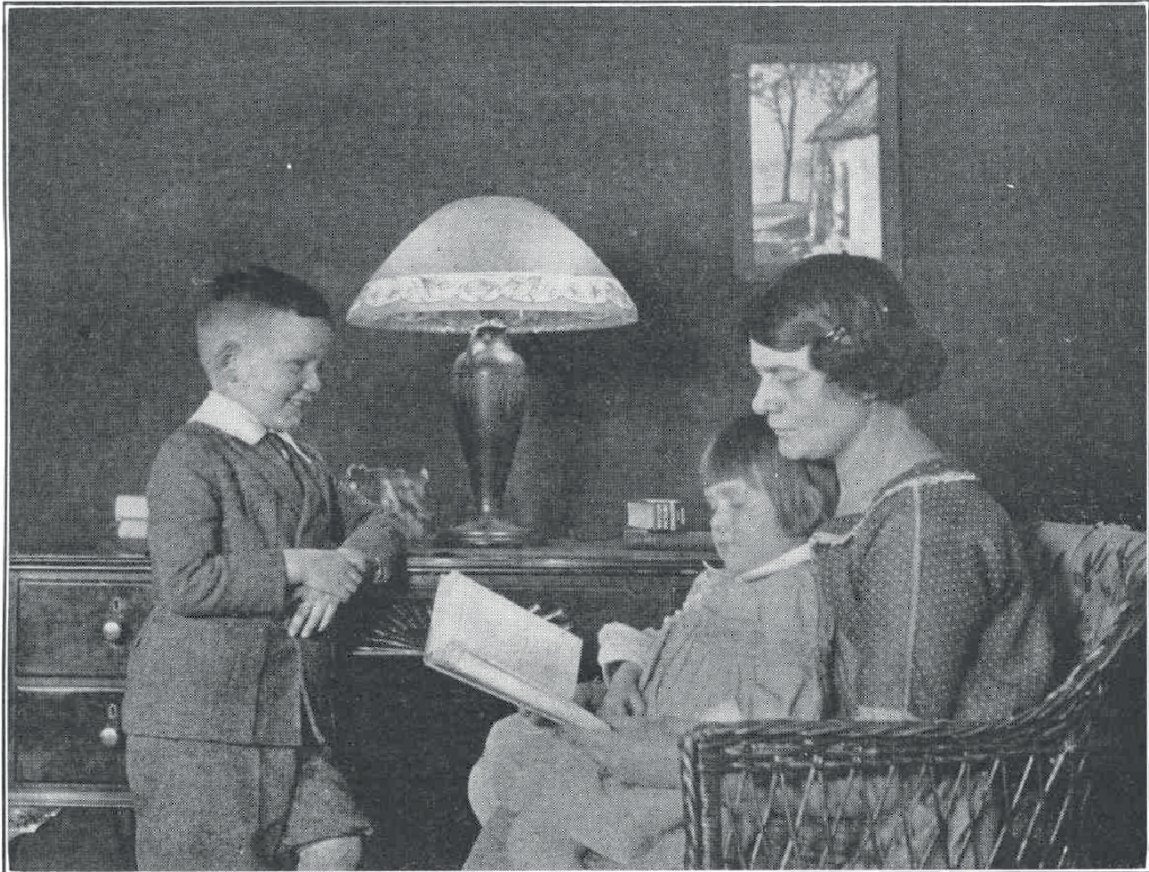

Diagram 6, of the room in which the picture on page 14 was made  
 S-Subject      C-Camera      F-Flashlight  
 R-Reflector    D-Doors      W-Windows



*“—and the little rabbit—”*

From Negative made with 2C Kodak Special by the light of one No. 1 Eastman Flash Cartridge. The table lamp was lighted. See diagram on page 17

Almost any lighting effects that may be desired can be secured with flashlight, owing to the fact that the flash can be so placed that its light will illuminate the subject from any direction. While nearly every lighting problem can be solved with flashlight, it should be remembered that the light of a flash is so intensely brilliant that it will fog the film if it shines on the lens. Before making a flashlight always observe whether the lens can be seen from the position where flash is to be ignited. If it can be seen, the lens should be shaded by placing, or having someone hold, a sheet of cardboard, or anything else that is a foot square, or larger, about a foot from the lens, to prevent the light from shining on it.

Instantaneous exposures can be made with Eastman Flash Cartridges and also with Eastman Spreader Flash Cartridges,

the latter being adapted for use in the Eastman Spreader Flash Cartridge Pistol.

With Eastman Flash Sheets time exposures of from one or two seconds, depending on the size of sheet used, can be made.

As all flashlight preparations are inflammable, they should be handled carefully. They should never be ignited closer than 3 feet to walls, ceilings, curtains, draperies or any paper.

Be sure to read and observe the precautions that the manufacturers recommend in the instructions that accompany all flashlight goods.

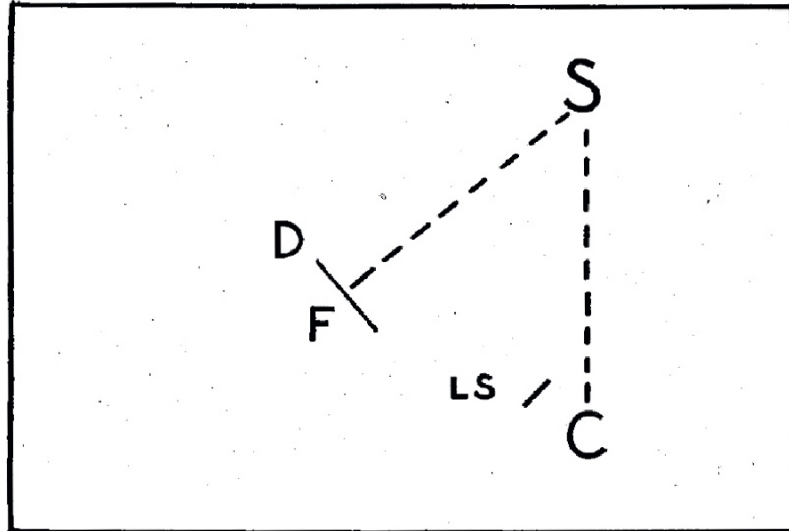

Diagram 7 showing how the picture on page 16 was made  
S-Subject C-Camera F-Flashlight D-Diffusing Screen  
LS-Cardboard for shading lens

## Indoor Story-telling Pictures

The chief difference between a portrait and a story-telling picture is that the former records the likeness of a person while the latter tells a story about a person.

Mother busy with her sewing, Dad reading the paper, the children at play—suggest but a few of the possibilities of this field of work.

In a story-telling picture the portrait is not only secondary to the story, but the picture can tell its story without showing the face of the subject. Any picture that shows someone actually doing something will tell a story, but a picture that shows the subject looking at the camera, instead of attending to the work in hand, may be, but more probably will not be, a story-telling picture.

All but young children can understand why they should not look at the camera while the picture is being made. There will



*A Natural Pose*

Made with No. 3A Kodak with Kodak Diffusion Portrait Attachment  
over lens. See diagram page 6

always be moments when children will pay no attention to the photographer or to the camera, if they are permitted to play in their own way with things that especially interest them, and it is during these moments that the pictures can be secured.

The subject should never be requested to "look pleasant," to "hold that position," or to do anything else. It is always best to let the subject alone and to make the exposure, without warning, at the instant when the story that you wish the picture to tell is being enacted.

These pictures can be made indoors, with the same lightings that are used for portraits. The illustrations on pages 2, 5, 9, 10, 16, 29 and 30 are story-telling pictures.

These are the types of pictures that will most vividly remind us of the many interesting incidents that occur in the daily routine of the home life. Children are excellent subjects, and they find it great fun to have their pictures taken. They are always delighted with pictures of themselves that were made without their knowledge.

## Kodak Portrait Attachment and Kodak Diffusion Portrait Attachment

These two attachments are supplementary lenses, mounted in light metal cells, which can instantly be slipped into place over the regular camera lens. Both attachments serve the purpose of short range work, *i.e.*, bringing the camera up close to the subject to secure a large image, but each gives a different rendition of the subject. The operation of the camera as well as the length of exposure remains unchanged.

The Kodak Portrait Attachment renders a *sharp image* close-up and makes possible head and shoulder portraits, such as the one on page 7. It is, as well, indispensable for photographing all sorts of small objects at short range, such as flowers, bric-a-brac, etc.

The Kodak Diffusion Portrait Attachment yields very pleasing results in *soft focus*, (see opposite page), faithful to

the subject in every detail, but with just enough diffusion of unpleasantly sharp lines and glaring highlights to artistically soften and enrich the picture, when such effects are desired.

These attachments are made in all the sizes that are needed for use with the various models of Kodaks and Brownies, and instructions for their use are furnished with each attachment. The price of the Kodak Portrait Attachment is 50 or 75 cents and of the Kodak Diffusion Portrait Attachment \$1.25 or \$1.50 (according to size). Exact designation of camera and lens and shutter equipment is necessary when ordering either attachment.

## Kodak Self Timer

On many occasions there is need for some device whereby a picture can be taken without having anyone at the camera to make the exposure. This problem of how to make a picture and also be included in it is easily solved by a Kodak Self Timer, a little device that can be used with any camera fitted with a cable release.

When attached to the cable release, the Kodak Self Timer can be so adjusted that it will "press the button" anywhere from  $\frac{1}{2}$  second up to one minute after the operator has left the camera. The Kodak Self Timer is only intended for making automatic exposures, that is, exposures that are made with a single pressure on the push button of the cable release.

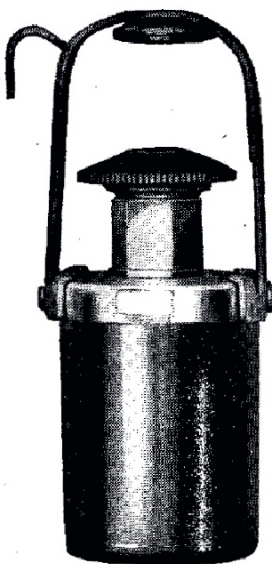

Kodak Self Timer

For making indoor portraits with the Self Timer, it is advisable to use a camera that has a cable release shutter which will make automatic exposures of half a second or one second, but as a one-half second, or even a one second exposure is a brief one for indoor portraiture, it will be necessary to use the largest stop and make the portraits on a bright day, with the subject close to a window which receives the unobstructed light from the sky.

The price of the Kodak Self Timer is \$1.25.

## Interiors by Daylight

In our picture making in and about the home we should not overlook photographing the rooms in which we live. It is probably because these pictures can be made at almost any time that we are apt to postpone making them, and the rooms may be papered, painted, newly furnished or remodeled before we remember that no pictures were taken, showing them as they were before the changes were made.

But a small percentage of the people who have reached middle age have any pictures that show the interior of the home of their childhood, and they keenly realize how imperfectly memory can recall the many details which only pictures can accurately record.

The interior of a living room must be photographed by giving a time exposure, since the light is so much weaker indoors than it is under the open sky, and, as pictures of interiors are made with the camera close to the subject, some parts of which may be only a few feet, while other parts may be several feet from the lens, a small stop must usually be used in order to obtain sharp images of all the objects that the picture records.

It is always best to arrange the furniture of a room as nearly as possible in the way it is customarily placed for home use, and then make two or more pictures of the room from different viewpoints. If a room is to be photographed from one viewpoint only, the temptation to crowd a lot of furniture into a small space may present itself, but this should always be avoided, for the picture will be far more pleasing if it suggests the com-

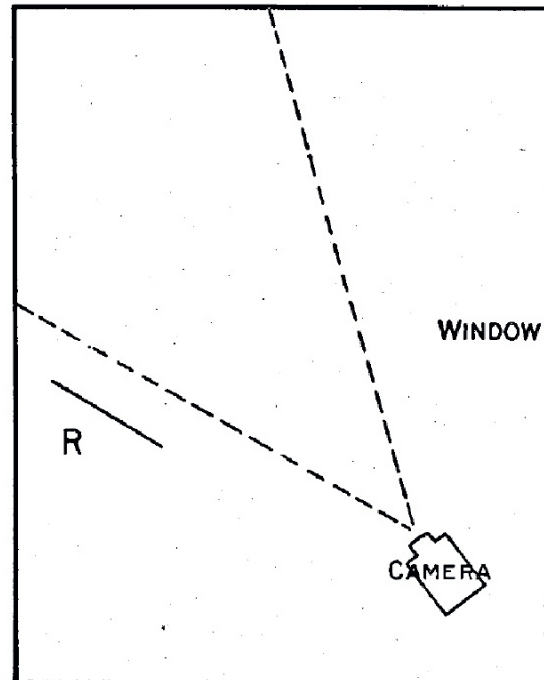

Diagram 8

forts of a living room than if it suggests the storage of furniture.

There should, whenever possible, be enough clear space between the lens and the nearest piece of furniture that is to be photographed, so that nothing but the floor can be seen in the immediate foreground. The reasons for this are, that any object which is very close to the lens will appear unduly large in comparison with objects that are farther away, and when a large object is much too close to the lens it will be impossible to include the whole of it within the picture area.

For photographing interiors the camera must be placed on a tripod or on some other rigid support, and it should be placed a little lower than is desirable for outdoor work, so that more of the floor than of the ceiling can be seen in the finder. If the picture shows more ceiling than floor it will look top-heavy.

If the furniture and walls are dark in tone it may sometimes happen that the outlines of the furnishings cannot be clearly seen in the finder. This difficulty can easily be overcome by having an attendant hold a lighted candle or a pocket flashlamp near the wall. As the light will show brightly in the finder, the outlines of the area that will be included in the picture can

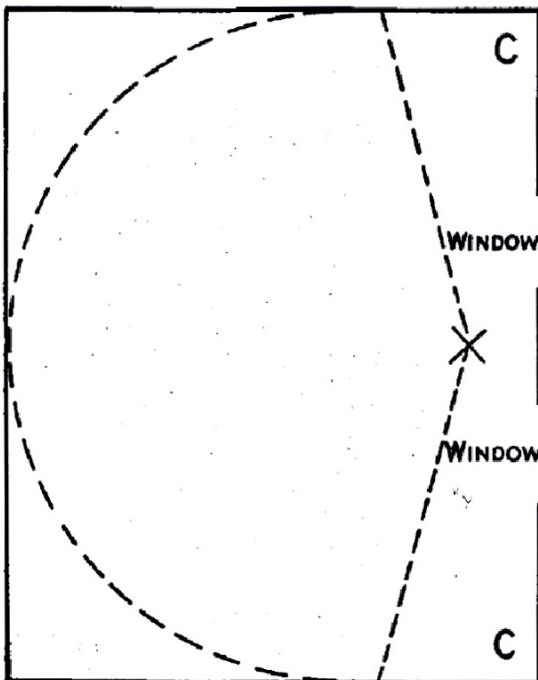

Diagram 9

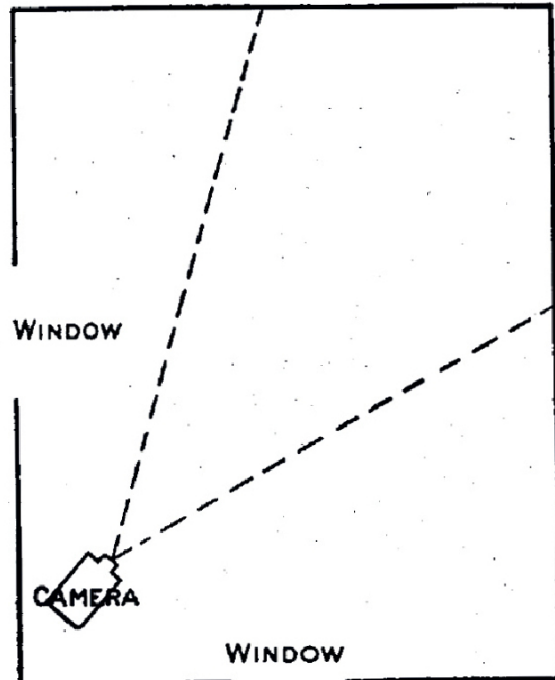

Diagram 10



*A Cheerful Corner*

Made with a 3A Kodak

11 A. M. January, Bright light outdoors, stop 16, exposure 25 seconds

be accurately determined, when the light is moved about near the wall, by observing where it is being held when its image can be seen on the four margins of the finder glass.

In rooms that have but one window a reflector may be needed for increasing the illumination of corners of the room. If the camera is placed at position indicated in Diagram 8, for photographing the corner that is diagonally opposite the camera, a reflector of white cloth or white paper, about the size of an ordinary window shade, placed at position R, will improve the illumination.

Rooms that have two or more windows on one side can usually be satisfactorily lighted without the aid of a reflector. Such rooms can easily be photographed from various viewpoints. Diagram 9 shows that with the camera at position X a series of pictures can be made which will include the area through which the dotted curved line passes. Other available camera positions are suggested by the letters C in Diagram 9.

Diagram 10 shows a good position for the camera when picturing the interior of a room that has windows on two of its sides. With the camera in the position suggested, no reflector will be needed.

Interiors are usually photographed by the light that comes through windows on which the sun is not shining, but they can also be successfully photographed by the light that comes through windows on which the sun is shining. All that is necessary is to subdue the sunlight by placing muslin or cheesecloth screens over the windows. While the use of such a screen will make it necessary to give

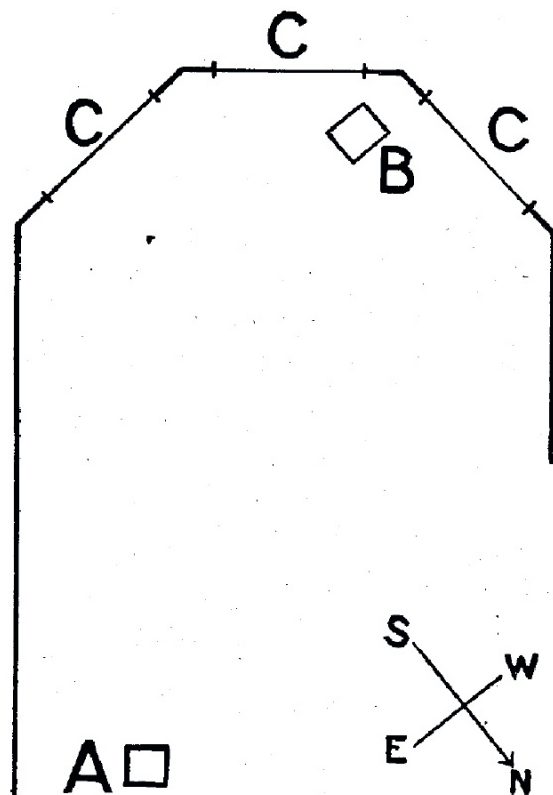

Diagram 11 showing arrangement of room in which picture on page 23 was made  
A-Camera B-Subject C-Windows

twice as long exposures as are recommended in the appended table, the screen will diffuse the light so that the shadows will not be as dark as if no screen was used.

With cameras that have double lenses (rectilinears and anastigmats) use stop 16, and with single lens cameras use the second stop, and give the exposures recommended in the following table:

## Exposure Table for Photographing Interiors

For rooms that receive the direct light from the sky. The exposures to be made not earlier than three hours after sunrise or later than three hours before sunset. In earlier morning or later afternoon hours longer exposures must be given.

White walls and more than one window:

Bright sun outside, 4 seconds  
Hazy sun, 10 seconds  
Cloudy bright, 20 seconds.  
Cloudy dull, 40 seconds.

White walls and only one window:

Bright sun outside, 6 seconds.  
Hazy sun, 15 seconds.  
Cloudy bright, 30 seconds.  
Cloudy dull, 60 seconds.

Medium colored walls and hangings and more than one window:

Bright sun outside, 8 seconds.  
Hazy sun, 20 seconds.  
Cloudy bright, 40 seconds.  
Cloudy dull, 80 seconds.

Medium colored walls and hangings and only one window:

Bright sun outside, 12 seconds.  
Hazy sun, 30 seconds  
Cloudy bright, 60 seconds.  
Cloudy dull, 120 seconds.

Dark colored walls and hangings and more than one window:

Bright sun outside, 20 seconds.  
Hazy sun, 40 seconds.  
Cloudy bright, 80 seconds.  
Cloudy dull, 2 minutes, 40 seconds.

Dark colored walls and hangings and only one window:

Bright sun outside, 40 seconds.  
Hazy sun, 80 seconds.  
Cloudy bright, 2 minutes, 40 seconds.  
Cloudy dull, 5 minutes, 20 seconds.

## Interiors by Flashlight

Owing to the location of the windows it may be impossible to satisfactorily photograph some parts of a room by daylight. To adequately picture a room we must photograph it from different viewpoints and must have windows show in some of the pictures. If the pictures are made by daylight, with the window shades drawn down, they will suggest that the room was photographed at night, and if the shades are left up the window areas will be hopelessly over-exposed, if a long enough exposure is given for recording the walls and furnishings.

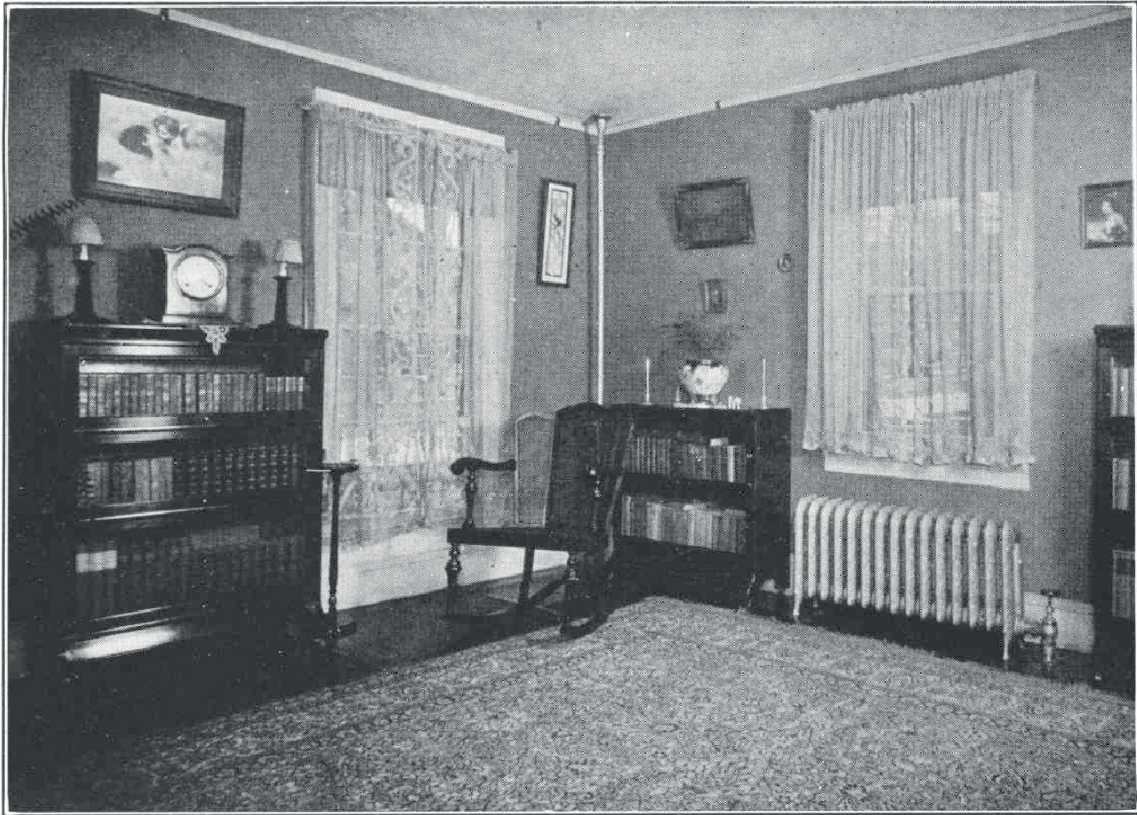

Fig. 1

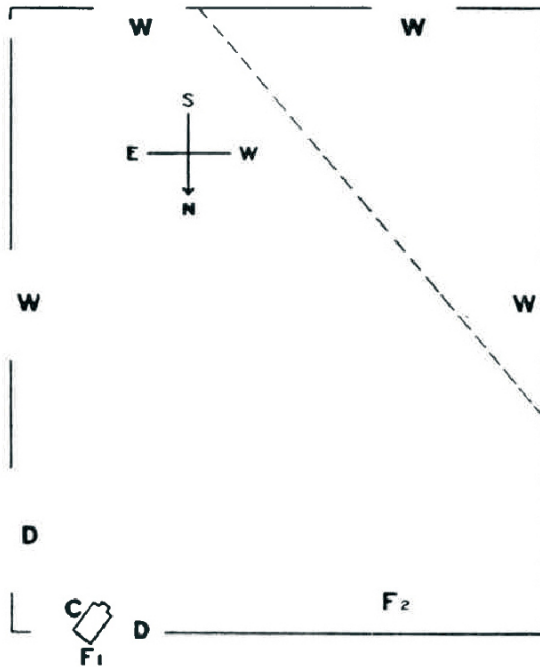

Diagram 12 showing how Fig. 1 was made  
 C-Camera F1 and F2 Flashlights  
 D-Doors W-Windows  
 Area beyond dotted line is included in picture

To make clear how easily such problems can be solved with flashlight we will explain how the picture above and those on pages 27 and 28 were made. These pictures were reproduced from Kodak film negatives that were exposed by flashlight, in the daytime, with the daylight shining through all the windows in the rooms. Satisfactory pictures of these subjects cannot be made by daylight, because all the walls and furnishings are so dark in tone that they reflect very little light.

Figure 1 was made at 4:30 P. M. on a dull day in Novem-



Fig. 2

ber. The window curtains were of unbleached linen, the bookcases were red mahogany, the rocker was black walnut and the wall paper was tan colored.

The lens was stopped down to 16 and, immediately after the shutter was opened, two Eastman Spreader Flash Cartridges were ignited at the positions F1 and F2, shown in diagram 12. The shutter was closed as soon as possible after the flashlights had been made.

Though the light from the flashes reached the subject at different angles, only one set of shadows can be seen in the picture. This is because the flashlight at position F1 was held directly above the camera so that this flash would cast the shadows behind the objects.

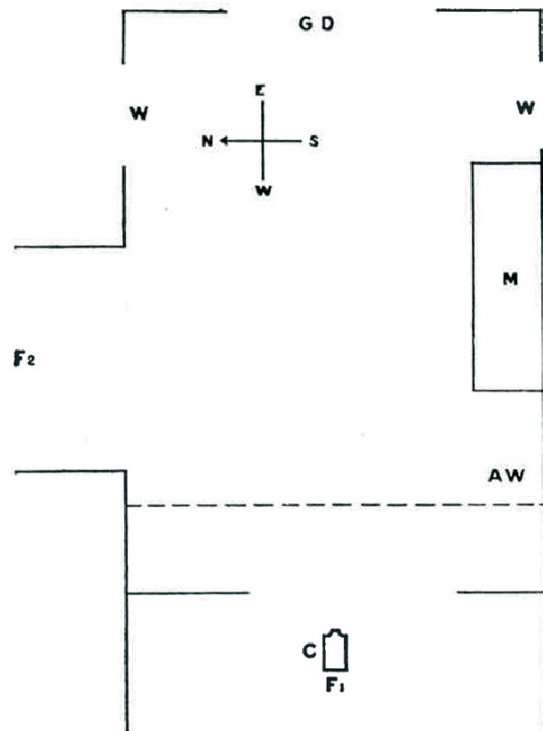

Diagram 13, of room pictured in Fig. 2  
 C-Camera F1 and F2-Flashlights  
 G D-Glass Door W-Windows M-Mantel  
 A W-Alcove and window  
 The picture includes area beyond dotted line

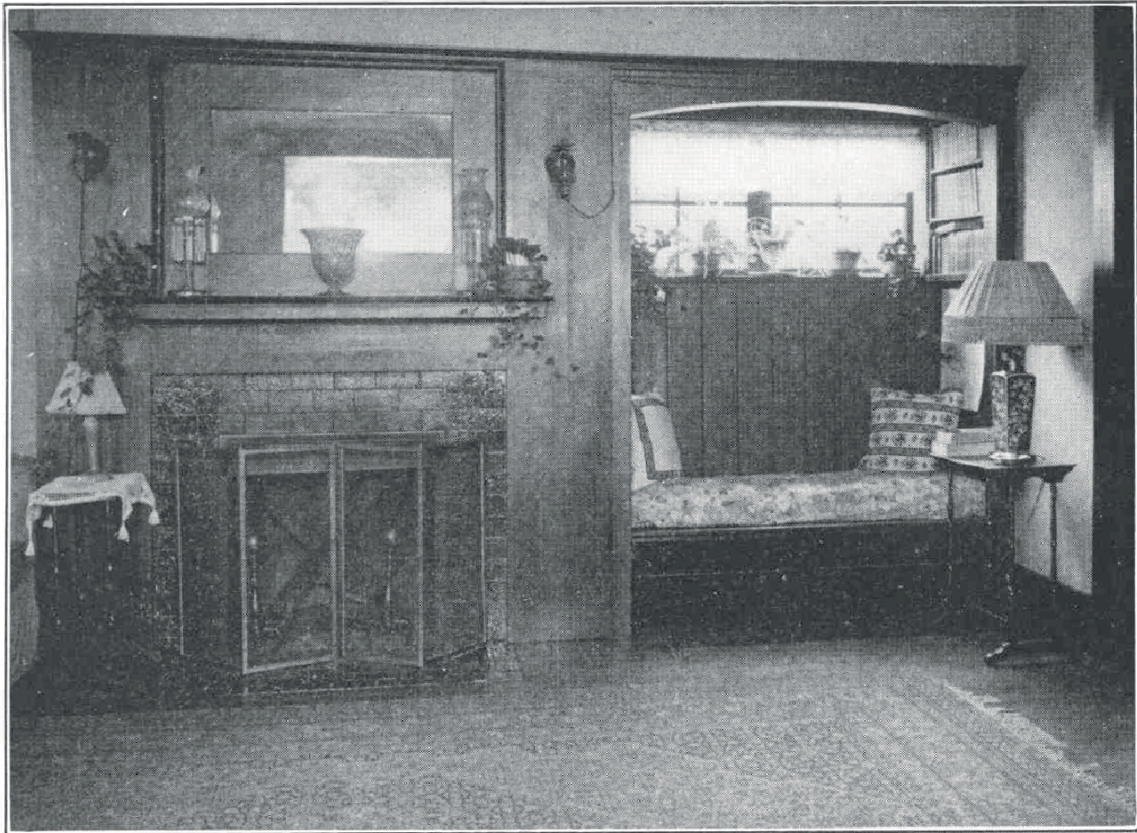

Fig. 3

Fig. 2 was made at 10:30 A. M. during a November snow-storm. Stop 16 was used and two flashlights were ignited at the positions shown in Diagram 13. With the exception of the floor, practically everything that can be seen to the left of the center of the glass door was but weakly illuminated by the daylight in the room, so that most of the light that made the picture came from the flashlight at position F1. The light at F2 helped to illuminate those parts of the room that are to the right of the center of the glass door.

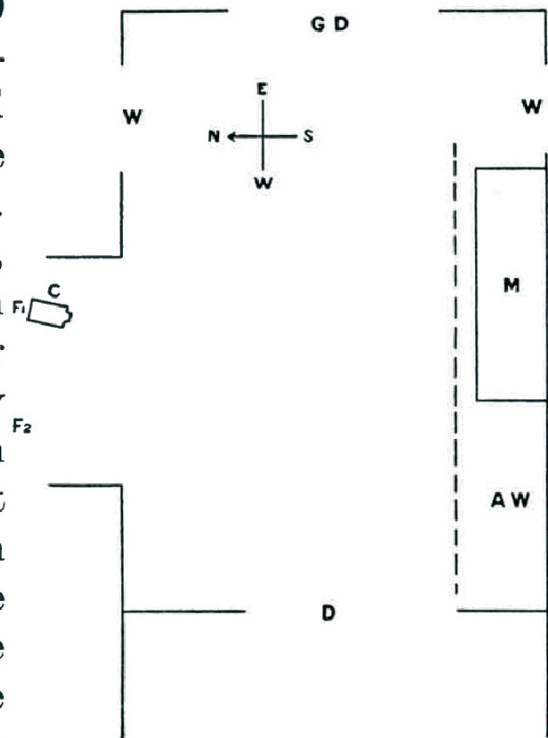

Diagram 14, of room pictured above. All at right of dotted line is shown in picture

Fig. 3 was made an hour later. This was a difficult subject. The snowstorm had passed and, though the sun was not shining, the outdoor light was quite brilliant and it was reflected into the alcove window by the snow on a nearby roof. This window was, in consequence, very brightly illuminated, but the mantel and the fireplace were so dimly lighted that it was necessary for an assistant to move about with a lighted candle, in order to enable the photographer, by observing what the finder showed in line with the candle, to determine what would be included in the picture.

This picture was also made by stopping down the lens to 16. Two Eastman Flash Cartridges were ignited at positions F1 and F2 shown in Diagram 14.

While these pictures were made with two flashlights, this is seldom necessary, unless the rooms are furnished in dark tones or are very large.

All who use flashlight preparations should use them with the care and in the manner that the manufacturers recommend in the instructions they furnish with the preparations.

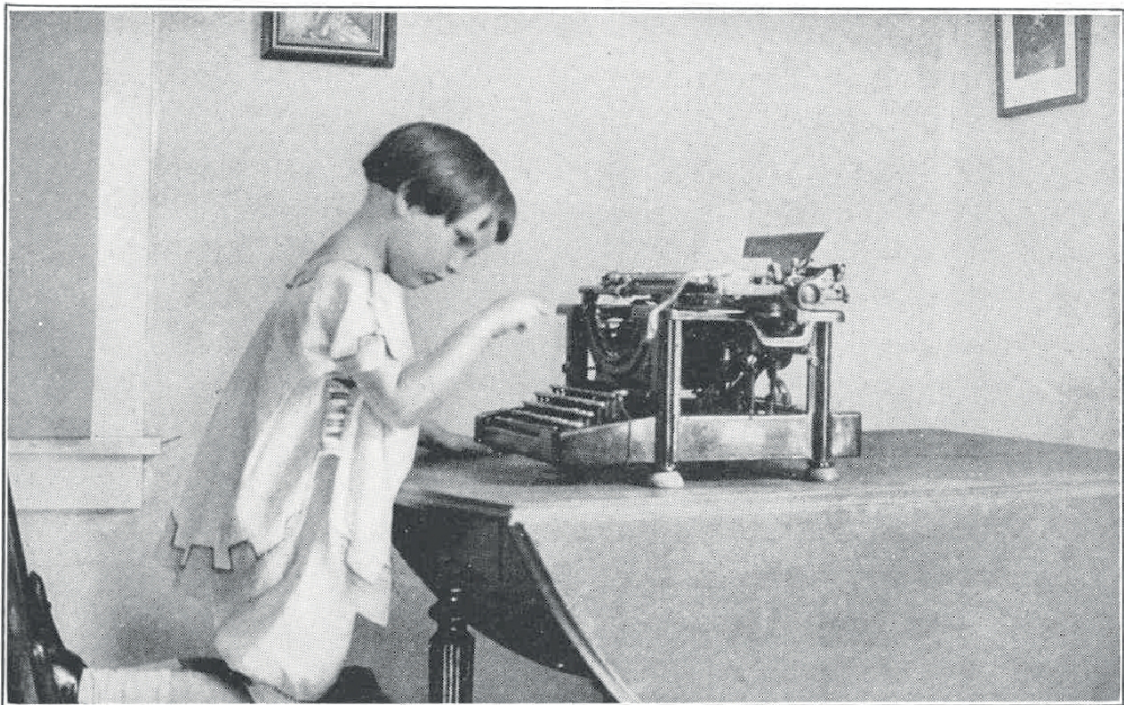

*The One Finger System*

From negative made with No. 1 Pocket Kodak, Series II, Kodak Anastigmat *f*.7.7

## In the Home Grounds

All of home is not included in the house in which we live. The grounds that surround it, the lawn and the garden where we spend our summer evenings, are so intimately associated with our home life that we rightly regard them as a part of the home.

Picturing the buildings and the garden, and making portraits and story-telling pictures in the home grounds, is a very simple matter, for these pictures can be made with snapshot exposures.

In making outdoor portraits and story-telling pictures the subjects are usually photographed at distances ranging from six to twenty-five feet. Since the persons portrayed should always appear more prominent in the picture than the background against which they are photographed, it is quite important to pay attention to what is behind our subject.

The side of a clapboarded house, unless so far away as to be out of focus, should never be used as a background for a portrait or a story-telling picture, because the boards will show prominently, as parallel lines, all extending in the same direction.



*Backyard Baseball*

Made with a 1A Pocket Kodak, Series II, with Kodak Anastigmat lens *f*.7.7

Shrubbery, vines and other objects that do not contain a lot of prominent lines often make the best backgrounds that can be found about the home.

The tables below recommend the shutter speeds and the stops to use for outdoor pictures about the home. The first table applies to cameras that have double lenses (rectilinears and anastigmats) and the second one applies to all cameras that have single lenses. (Single lenses are mounted behind the shutter, and they cannot be seen when the shutter is closed.)

Story-telling pictures can be made with the same exposures that are recommended for portraits.

The tables state the exposure to give for portraits in the shade. Both portraits and story-telling pictures are, however, often made when the subjects are in bright sunlight. When this is done, the exposure recommended for nearby landscapes should be given. It should be remembered that all people will partly close the eyes when the sun shines on the face. If a hat is worn, for keeping the sun out of the eyes, the shadow of the hat will show on the face and, whether a hat is worn or not, the eyes will not be as clearly defined in a picture made in sunlight as in one that is made in the shade.

That this is not always a detriment is shown by the picture on page 3.

**OUTDOOR EXPOSURE TABLE FOR CAMERAS THAT HAVE  
RECTILINEAR OR ANASTIGMAT LENSES**

*For 2½ hours after sunrise until 2½ hours before sunset on days when the sun is shining*

	Shutter Stop	Rectilinear Lenses Stop	Anastigmat Lenses Stop
Nearby Landscapes showing little or no sky— Groups, Street Scenes . . . . .	1/25	8	11
Portraits in the Open Shade, not under Trees or the Roof of a Porch—Shaded Nearby Scenes . . . . .	1/25	4	7.7 or 8

**OUTDOOR EXPOSURE TABLE FOR ALL CAMERAS THAT  
HAVE SINGLE LENSES**

*For 2½ hours after sunrise until 2½ hours before sunset on days when the sun is shining*

Nearby Landscapes showing little or no sky— Groups, Street Scenes . . . . .	Snapshot with Largest Stop
Portraits in the Open Shade, not under Trees or the Roof of a Porch—Shaded Nearby Scenes . . . . .	1 second with Third Stop

## Kodakery

For those who desire comprehensive information regarding outdoor and indoor picture making we publish Kodakery, a magazine which is issued monthly.

Kodakery gives instruction in all branches of photography, from the exposure of the film to the finishing of the print. It is sent, free of charge, to every purchaser of a Kodak, Brownie, Premo, Graflex or Graphic camera, who fills out and mails to us the subscription blank in the instruction book which is furnished with the camera.

Specific information regarding anything pertaining to amateur photography can also be obtained by addressing our Service Department. One of the functions of this department is to assist photographers in solving any photographic problems that may confront them. For this service there is no charge.

EASTMAN KODAK COMPANY,  
ROCHESTER, N. Y.

## Always Write the Date on the Negatives of the Children

There are many negatives that should bear a date and title. Travel pictures sometimes lose their interest because we cannot just remember where they are made; pictures that are made for business purposes become authentic records when they bear a date and title. Oftentimes it is interesting to write upon the negative the names of traveling acquaintances whom we photograph or, better still, have them write their own names, thus bringing picture and autograph together.

But there is one class of negatives in particular that should always bear a date—negatives of the children. So soon do the children outgrow childhood, so rapidly do they change, so fallible is memory that, as the leaves of the old Kodak album are turned, the invariable questions are: "How old was Mary when this was taken?" or "Why didn't we date this picture of Harry? From his face, he looks to be seven, but those rompers make him look like four—too bad we now have no means of telling *for sure*."

An autographic date on the film would have answered.

With an autographic Kodak or Brownie and autographic film, you can write the date and title on the film at the time of exposure. It's the work of but a moment.

You may not care to date and title every negative—but your equipment, to be up-to-date, must provide for the making of autographic records when you do want them. Every folding Kodak and every Folding Brownie is "Autographic." And there is no extra charge for autographic film.

Kodak was first in roll films, first in daylight loading, first in non-curling film, first in daylight development, the first to have, and because the patents still protect, the only line that has the autographic feature.

EASTMAN KODAK COMPANY  
Rochester, N. Y.

*February, 1924*

Miss Coletta Cornett  
Hudsonville  
Michigan

P.F.D. 5

December 24, 1925

Age 17 years.