

**Kodak**

# PHOTO DEPARTMENT COUNTER CATALOG

1964 SPRING-SUMMER / NO. A2-11



*save your  
Summer fun in pictures*

*make sure your  
camera is loaded with  
dependable Kodak film*



# KODAK Films in KODAPAK Cartridges

(SIZE 126)

Four popular Kodak films are supplied in factory-sealed, precision-molded KODAPAK Cartridges for instant loading into KODAK INSTAMATIC Cameras. The lighttight cartridges can be easily and safely inserted into and removed from the camera even in direct sunshine. Each exposure is 26 x 26mm in size and is rapidly and automatically positioned by metering perforations in the film margin. For electric-eye KODAK INSTAMATIC Cameras, the cartridge automatically sets the camera for the speed of the film being used.



## FOR BLACK-AND-WHITE SNAPSHOTS

### KODAK VERICHROME Pan Film—VP126

Popular all-purpose film for black-and-white snapshots indoors or out. Its excellent speed makes it ideal for all-around use. The standard-size print measures 3½ x 3½ inches and greater size enlargements are also available because of the fine grain.

VP126—12 exposures—List per Cartridge  
20 Cartridges to a package..... **\$ .75**



## FOR COLOR SLIDES

### KODACHROME-X Film—KX126

New faster KODACHROME-X Film with an ASA speed of 64 daylight. Can be used outdoors or indoors with blue flashbulbs. Yields twenty 28 x 28mm transparencies mounted in 2 x 2-inch cardboard mounts for viewing or projection.

KX126—20 exposures—List per Cartridge  
20 Cartridges to a package..... **\$2.15**

## FOR COLOR SLIDES



### KODAK EKTACHROME-X Film—EX126

New fast film with ASA speed of 64 for color slides—color balanced for exposure by daylight or with blue flashbulbs indoors. The extra speed helps assure good pictures in shade or on dull days, permits faster shutter speeds for action shots. Yields twenty 28 x 28mm transparencies in 2 x 2-inch mounts.

KODAK EX126—20 exposures—List per Cartridge  
20 Cartridges to a package..... **\$2.35**

## FOR COLOR SNAPSHOTS



### KODACOLOR-X Film—CX126

Improved sharpness and graininess with higher speed (ASA 64) to give sharper, more pleasing color prints under a wide range of light, indoors or out—daylight or clear flash. This film gives you twelve 28 x 28mm negatives from which standard 3½ x 3½-inch color prints are made.

CX126—12 exposures—List per Cartridge  
20 Cartridges per package..... **\$1.40**

Prices shown in this catalog are Kodak list, subject to change without notice, and are suggested prices only.

# KODAK INSTAMATIC Cameras

... easier than ever to take good pictures



## No. A100S KODAK INSTAMATIC 100 Outfit, \$17.95

Gives you ease, instant loading, lowest cost.

### Major Camera Features

- This is the simplest, lowest-priced of the KODAK INSTAMATIC Cameras. A big value — and it's actually easier to use than a box camera.
- Saves you time — gets you into action fast. Just drop the film in, snap the camera shut.
- Won't let you make mistakes. Film goes in only one way. No fumbling, no threading.
- Saves you bother. Nothing to focus, nothing to set. Aim and shoot!
- Gives you convenience indoors. Flash is built-in! Just pull it up, pop in an AG-1 flashbulb and shoot.
- Gives you built-in steadiness outdoors with fast shutter action for sharper pictures.
- Gives you safety. Film type and exposure number always visible. Double exposures automatically prevented.
- Gives you carrying ease. Camera is lightweight and compact.
- Outfit includes camera, wrist strap, flashguard, 2 AAA-size batteries, 4 AG-1 flashbulbs and a cartridge of VP126 Film.

No. C60C KODAK INSTAMATIC Field Case, Model A \$4.50



## No. A300S KODAK INSTAMATIC 300 Outfit, \$49.50

with automatic electric eye.

Electric Eye Gives You a Good Clear Shot Every Shot.

### Major Camera Features

- Electric eye automatically sets the lens for a good, clear, correctly-exposed picture every time . . . no exposures for you to calculate, no settings to make, no exposure errors! Does it in good light or dull . . . for color film or black-and-white — automatically!
- Gives you convenience — nothing to set. Lens is pre-set for sharp shots from 5 feet and beyond. If light is too dim for snapshots, an automatic signal in the viewfinder tells you to use flash.
- Makes flash pictures easy. Just pull up the built-in flashholder, pop in a bulb, and shoot.
- Gives you extra picture-taking hours. Fast  $f/8$  lens gets shots in dull light or late in the day, and at longer distances with flash.
- Gives you picture-taking speed. Film advances fast, as you move the thumb lever. Films stops automatically. You don't have to watch for exposure numbers.
- Gives you carrying ease, smartness, pride . . . with handsome camera styling, precision look, lightweight.
- Outfit includes camera, wrist strap, flashguard, 4 AG-1 flashbulbs, 2 AAA-size batteries, and a cartridge of VP126 Film.

No. C65C KODAK INSTAMATIC Field Case, Model B \$4.95



## No. A400S KODAK INSTAMATIC 400 Outfit, \$59.50

with automatic film advance and automatic electric eye.

Spring Motor Winds Film for You — Electric Eye Sets Correct Exposure Automatically!

### Major Camera Features

- The KODAK INSTAMATIC 400 Camera gives you automatic film-winding . . . automatic electric-eye exposure . . . plus all the convenience of instant loading!
- Keeps you always ready! Lets you catch all the action. You can snap complete picture stories . . . catch every expression and gesture . . . never lose an opportunity.
- Sets exposure for you. No matter how fast you shoot . . . even if the light is changing . . . the automatic electric eye measures the light and adjusts the lens for a clear shot every shot.
- Gives you convenience indoors. Pull up the built-in flash unit, and you're all set.
- Gives you extra shooting hours. Fast  $f/8$  lens lets you shoot in dull light or late in the day.
- Lens is pre-set for sharp shots from 5 feet onward. Just drop in the instant-load film cartridge. Spring-power positions the first exposure — nothing left to do but aim and shoot!
- Gives you carrying ease, smartness, pride . . . with handsome styling, precision look, light weight. Even with spring motor and electric eye, camera weighs only 15 ounces.
- Complete outfit includes camera, wrist strap, flashguard, 4 AG-1 flashbulbs, 2 AAA-size batteries, and a cartridge of VP126 Film.

No. C65C KODAK INSTAMATIC Field Case, Model B \$4.95



**NEW!**

*Slim...smart...only 15 ounces!*

## No. A500 KODAK INSTAMATIC 500 Camera, \$94.50

### Major Camera Features

- Slim, streamlined KODAK INSTAMATIC Camera with smart new Continental styling . . . built with the same precision as KODAK RETINA Cameras.
- Instant loading . . . just drop film cartridge in.
- Carries easily in pocket or purse . . . weighs only about 15 ounces . . . measures only  $4\frac{7}{8} \times 2\frac{5}{8} \times 2\frac{1}{4}$  inches with lens retracted.
- Fast  $f/2.8$  lens, 4-element, color-corrected, focusing as close as  $2\frac{1}{2}$  feet.
- Special Compur Shutter, speeds from  $1/30$  to  $1/500$  second, continuous to  $1/250$  and "B."
- Built-in electric eye . . . correct exposure is set as needle is centered in viewfinder . . . with plus or minus 1 stop "over" and "under" control for unusual exposure conditions.
- Rugged metal body . . . large projected-frame finder . . . built-in flash synchronization.

- No. C121F KODABLITZ Flashholder (Cordless) \$6.95 (At right) ▶  
 No. C85C KODAK INSTAMATIC Field Case, Model S \$14.95  
 No. C80C KODAK INSTAMATIC Pouch Case, Model R \$5.95  
 No. C75C KODAK INSTAMATIC Compartment Case \$16.95

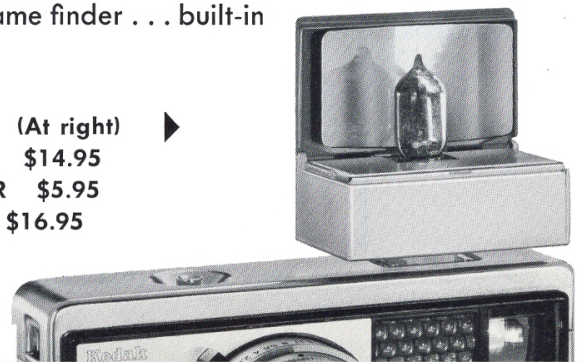

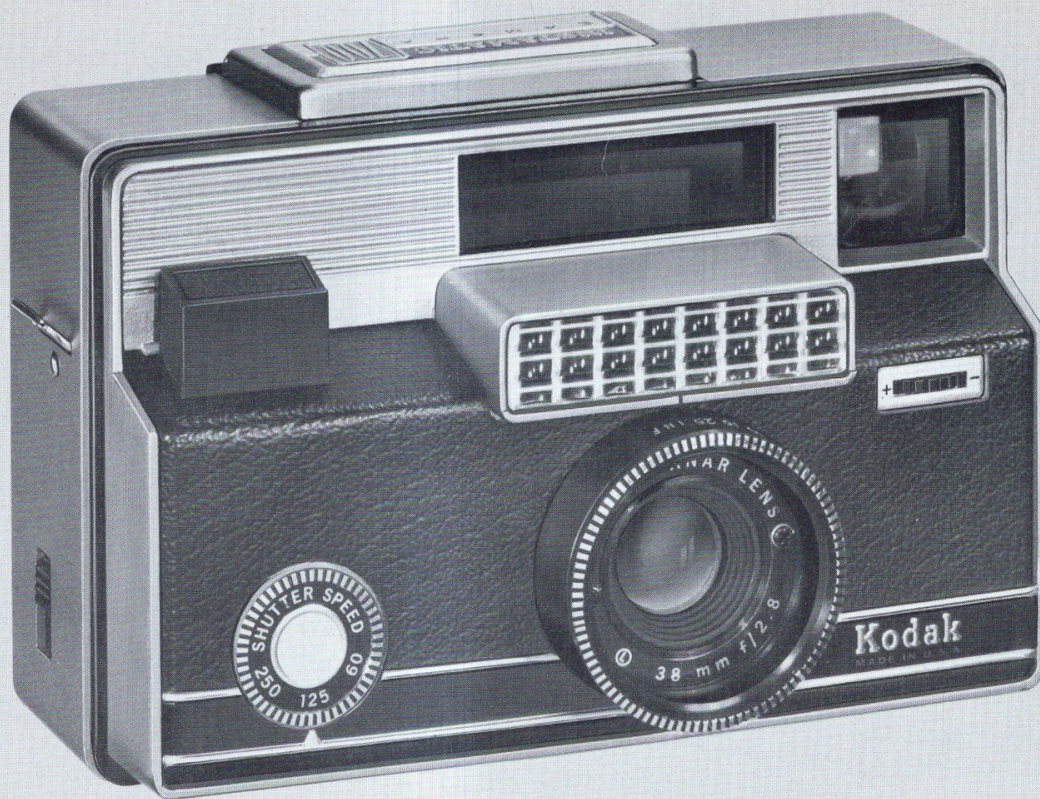

## No. A700 KODAK INSTAMATIC 700 Camera, \$109.50

Fast lens, fast shutter gives you extra power — automatic controls give you extra convenience.

### Major Camera Features

- This is one of the two most advanced of the KODAK INSTAMATIC Cameras with extra power to handle any picture situation. Has sharp, fast  $f/2.8$  lens for shooting in sun or shade, or available-light indoors without flash . . . and high-speed shutter with settings up to  $1/250$  second for sharp pictures of fast-moving subjects.
- Sets exposure for you. Electric eye automatically measures the light and sets the correct lens opening for any shutter speed you select. Automatic signal in viewfinder tells you when to use flash.
- Sets flash exposure, too! Automatic flash control adjusts the lens as you focus for flash shots, to give you good exposures every time.
- Flashholder is built-in; just flip up reflector, insert AG-1 flashbulb, set lens for correct distance to subject (as close as 3 feet) and shoot.
- Gives you convenience — does everything for you. Loads instantly. The film cartridge automatically sets the camera for the speed of the film you're using — no setting to make. Automatic lock prevents double exposure. Film advances with a stroke of the thumb, and stops at the right point — no need to watch numbers!
- Gives you carrying ease, smartness, pride — with handsome camera styling, precision look, light weight. Comes with leather neck strap, 2 N-size batteries and flashguard.

No. C70C KODAK INSTAMATIC Field Case, Model C \$9.95

No. C75C KODAK INSTAMATIC Compartment Case \$16.95

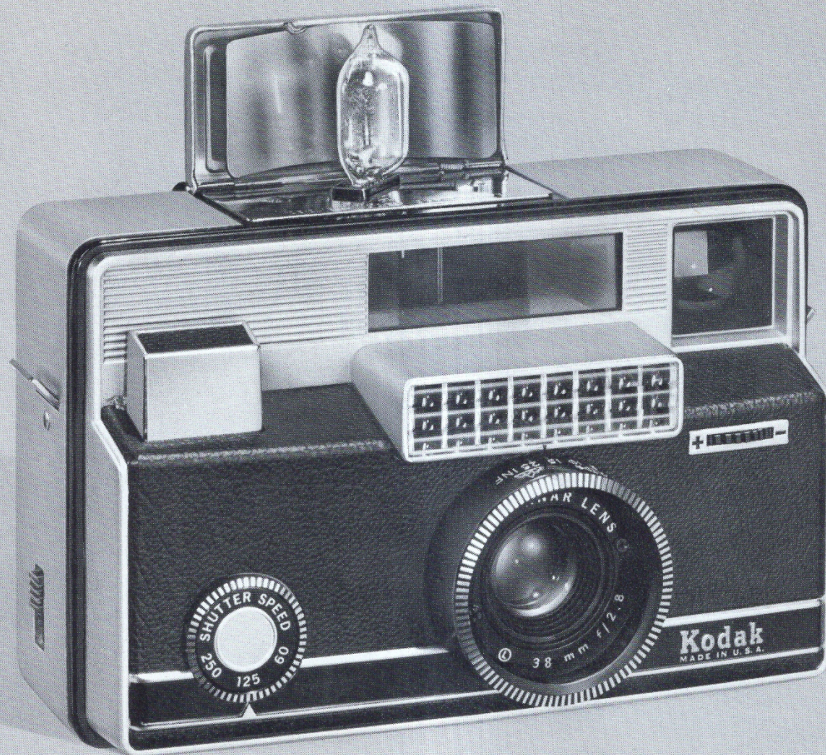

**NEW!**

- Coupled Rangefinder
- Motor Drive
- Electric Eye

## **No. A800 KODAK INSTAMATIC 800 Camera, \$129.50**

(Motor-rangefinder companion to the KODAK INSTAMATIC 700 Camera model)

### **Major Camera Features**

- Most automatic, most complete of the instant-loading KODAK INSTAMATIC Cameras.
- Coupled rangefinder combined with viewfinder. Has dim-light signal.
- Spring motor advances film automatically—a full 20 exposures on one winding.
- Electric eye sets fast  $f/2.8$  Lumenized lens for daylight shots, automatically.
- Automatic flash exposure control sets correct lens aperture as you focus in 3-to-25-foot range. Uses AG-1 bulbs and 2 N-size batteries.
- Quick-action focus settings for "Close," "Group," "Scene."
- Drop film cartridge in, and camera is set automatically for correct speed of film.
- Quick manual exposure compensator for unusual exposure conditions.
- Shutter speeds range from 1/250 to 1/60 second—are automatically reduced to as low as 1/30 second when required by lighting conditions.
- Comes with leather neck strap, 2 N-size batteries and flashguard.

No. C70C KODAK INSTAMATIC Field Case, Model C \$9.95

No. C75C KODAK INSTAMATIC Compartment Case \$16.95

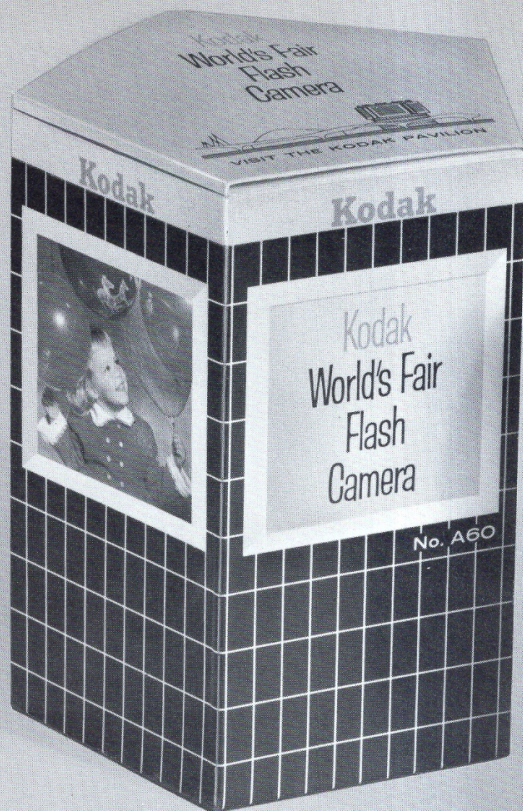

© 1961 New York World's Fair 1964-1965 Corporation

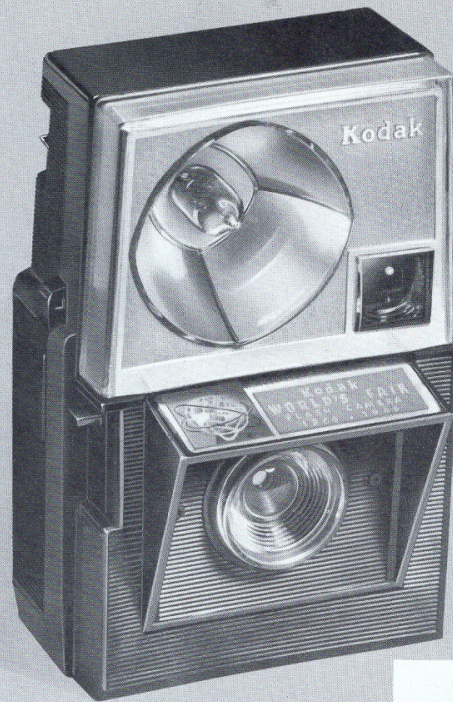

**NEW!**

## **No. A60 KODAK World's Fair Flash Camera, \$7.95** (In unique five-sided souvenir box)

### **Major Camera Features**

- Smart new flash camera at low price, to capitalize on New York World's Fair excitement for you.
- Compact, easy to use, gets black-and-white and color snaps and color slides, indoors or out, night or day.
- Built-in flashholder, very compact, always ready, accepts economical AG-1 bulbs. Flash distances right on camera.
- Factory pre-set lens, no focusing needed, no setting of lens openings — just aim and shoot.
- Large optical eye-level finder, bright, distortion-free.
- Large, smooth-action shutter release for sharp, steady shots.
- Attractive styling in black with bright metallic-finish front.
- Supplied with sturdy clip-on neck strap for easy carrying.
- Accepts 2 AA-size batteries (extra) and KODAK No. 6A Lens Attachments.

No. 24C Carrying Case \$4.25

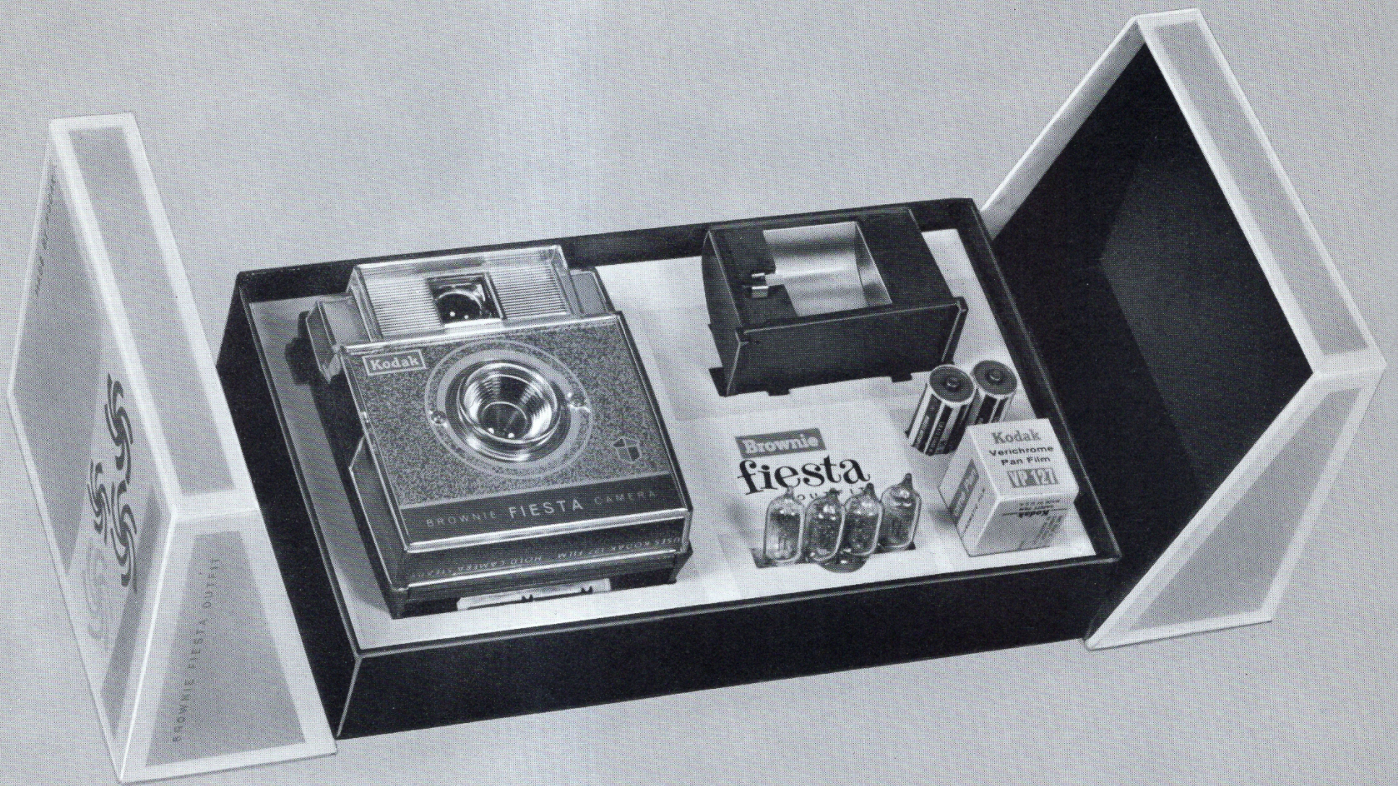

## No. 181J BROWNIE FIESTA Camera Outfit, \$9.95

Handsome new grey-and-silver camera . . . smart, compact slip-on flashholders . . . neckstrap, batteries, bulbs, film . . . all in handsome box

### Major Camera Features

- Sharp pre-focused lens for snaps and super-slides
- Clear direct optical finder . . . extra-soft shutter release
- Easy loading . . . completely removable back . . . and illustrated instructions right on the camera
- Neat, compact Brownie Fiesta flashholder slides on top of camera . . . resembles built-in flash unit
- Clip-on neck strap for easy carrying
- Sturdy construction . . . high-impact molded material . . . beautiful two-tone grey and silver styling . . . only 7 ounces
- Makes 12 exposures on a roll of No. 127 film
- Outfit contains camera, flashholder, 2 batteries, 4 AG-1 bulbs, flash-guard, neck strap, and 1 roll of VP127 film



No. 181 BROWNIE FIESTA Camera \$5.95  
 No. 781 BROWNIE FIESTA Flashholder \$2.50  
 No. 25/23C Carrying Case \$2.75



## No. 48J BROWNIE STARMITE II Outfit, \$13.50

New Night-and-Day Camera Outfit for Indoor-Outdoor Fun

### CAMERA FEATURES

**Small, powerful!** Flashholder built in. Tiny, mirror-bright reflector uses new low-cost AG-1 bulbs. Full output for bright, clear pictures.

**Light, compact!** Handy size, easy to carry, only 8 ounces. But it shoots color snaps, black-and-whites, and beautiful color slides . . . 12 on each roll of size 127 film.

**No mistakes!** Automatic double-exposure prevention. And a bright, sharp eye-level viewfinder, for clear framing of every shot.

**No focusing needed!** Lens is accurately pre-set at factory for both close-up and distant shots.

**Handsome styling** in blue-grey with contrasting light grey, and bright metal parts makes it attractive to carry anywhere.

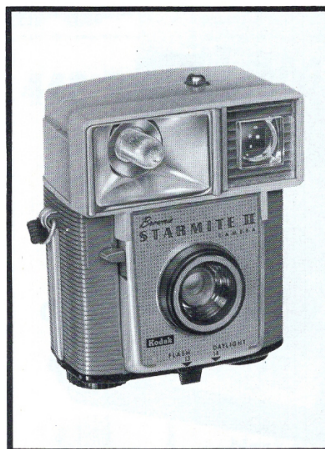

### CONTENTS OF OUTFIT:

BROWNIE STARMITE II Camera  
One roll KODAK VERICHROME  
Pan 127 Film

Four AG-1 flashbulbs

Two AA-size batteries

Neck strap and instruction book

No. 48 BROWNIE STARMITE II  
Camera \$11.95

No. 25/23C Carrying Case \$2.75

# Popular BROWNIE Star Outfits

## No. 25H BROWNIE STARFLEX Outfit, \$18.95

The popular BROWNIE STARFLEX Camera with large, bright reflex finder—features double-exposure prevention; compact, lightweight design.



BROWNIE STARFLEX Camera  
KODAK SUPERMITE Flashholder  
Two AA-size batteries  
Six AG-1 flash bulbs  
One roll KODAK VERICHROME Pan 127  
Film (12 exp. per roll)  
Neck strap  
Instruction book

No. 25/23C Carrying Case \$2.75

## No. 29H BROWNIE STARMETER Outfit, \$28.75



- **Sales-winner** for the customer who wants a compact camera with built-in exposure meter at a low, low price.
- **Selling feature:** Quick-reading photoelectric exposure meter to insure a correctly-exposed shot every shot.
- **Selling points:** Simple, easy-to-read exposure meter for correct exposure. Sharp, color-corrected, easy-to-set  $f/8$  lens. No focusing required. Double-exposure prevention. Bright eye-level finder. Flash synch for all popular bulbs. Smart finish, lightweight, carries easily on neck strap.
- **Outfit includes:** Camera, KODAK SUPERMITE Flashholder, 4 AG-1 bulbs, 2 AA-size batteries, neck strap, and roll of VP127 film.

No. 29 BROWNIE STARMETER Camera \$22.95  
No. 25/23C Carrying Case \$2.75

# Popular BROWNIE 20 Outfits

## No. 42E BROWNIE Twin 20 Outfit, \$18.95

The BROWNIE Twin 20 has both eye-level and waist-level finders and these modern improvements: automatic film stop, zone focusing, easy-to-hold design.

### Outfit

BROWNIE Twin 20 Camera  
 KODAK SUPERMITE Flashholder  
 Two rolls KODAK VERICHROME Pan 620 Film  
 (12 exp. per roll)  
 Six AG-1 flash bulbs  
 Two AA-size batteries  
 Neck strap  
 Instruction book

No. 44/42C Carrying Case \$5.25

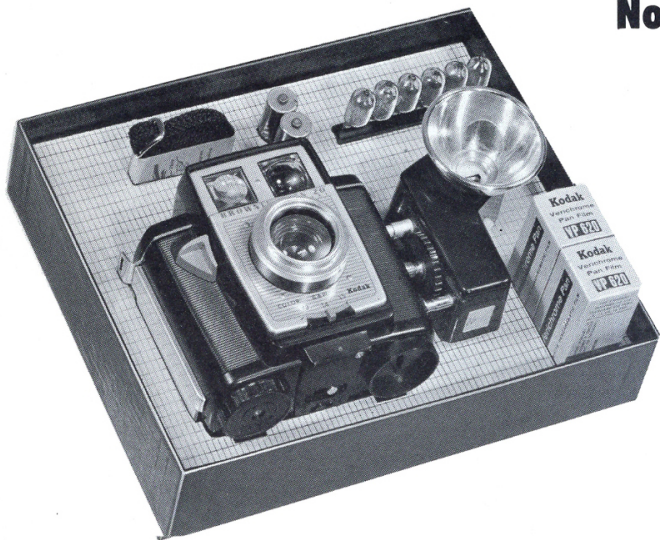

## No. 47H BROWNIE FLASHMITE 20 Outfit, \$18.95

Indoors or out, the easy-to-use two-tone grey BROWNIE FLASHMITE 20 is ready for color or black-and-white snaps and color slides. Has built-in flashholder for AG-1 bulbs; double-exposure prevention.

### Outfit

BROWNIE FLASHMITE 20 Camera  
 One roll KODAK VERICHROME Pan 620 Film  
 (12 exp. per roll)  
 Six AG-1 flash bulbs  
 Two Penlite batteries  
 Neck strap  
 Instruction book

No. 47 BROWNIE FLASHMITE 20 Camera \$17.50  
 No. 44/42C Carrying Case \$5.25

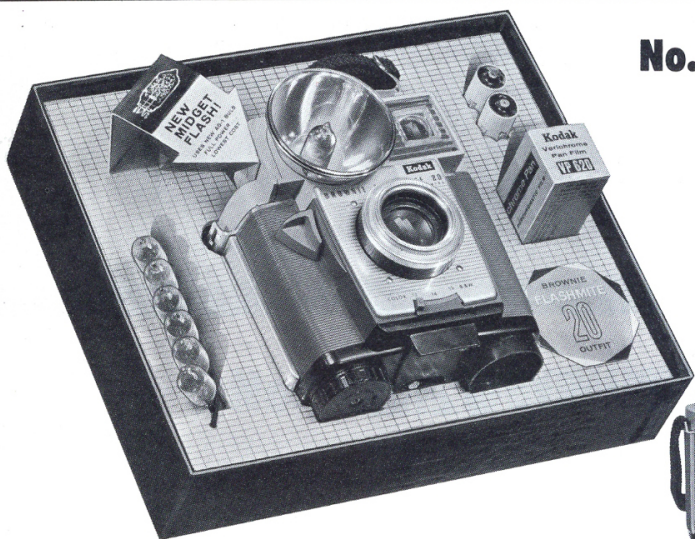

## No. 44E BROWNIE Reflex 20 Outfit, \$26.25

The versatile BROWNIE Reflex 20 has large "preview" reflex finder. Features automatic film stop, easy zone focusing.

### Outfit

BROWNIE Reflex 20 Camera  
 KODALITE Midget Flashholder  
 Two rolls KODAK VERICHROME Pan 620 Film  
 (12 exp. per roll)  
 Six M2 flash bulbs  
 Two AA-size batteries  
 Neck strap  
 Instruction book

No. 44 BROWNIE Reflex 20 Camera \$19.50  
 No. 740 KODALITE Midget Flashholder \$4.50  
 No. 44/42C Carrying Case \$5.25

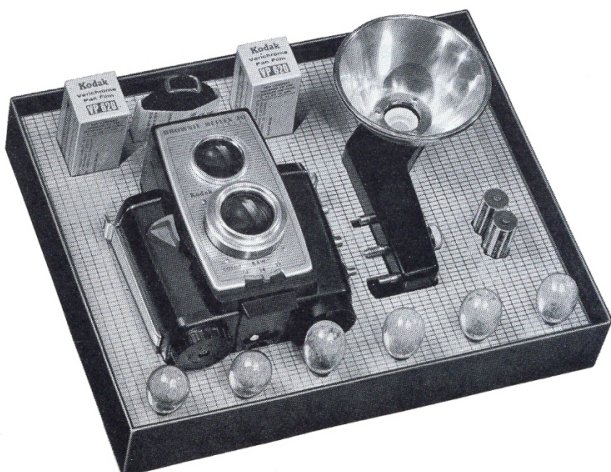



## No. 36K BROWNIE Super 27 Outfit, \$21.50

Sophisticated "new look" . . . easiest handling . . . sharpest pictures . . . indoors and out . . . night or day!

### Major Camera Features

- **Super-steady.** New sure-grip shape for easy hold, sharp shots!
- **Super-quality.** Sharp 3-element  $f/8$  color-corrected lens.
- **Super-convenience.** New "auto-shift" shutter automatically sets to  $1/40$  for best synch when flash lid is opened—and to  $1/80$  for sharp, steady outdoor shots when closed!
- **Super-thrift.** Built-in flash unit uses low-cost AG-1 bulbs. You get 12 snaps or color slides on a roll of No. 127 film.
- **Super-appearance.** Handsome finish, attention-getting shape.
- **Super outfit value.** Outfit contains camera, neckstrap, 1 roll of KODAK VERICHROME Pan 127 Film, 4 bulbs, 2 batteries, instructions.

No. 36FC BROWNIE Super 27 Field Case \$4.75

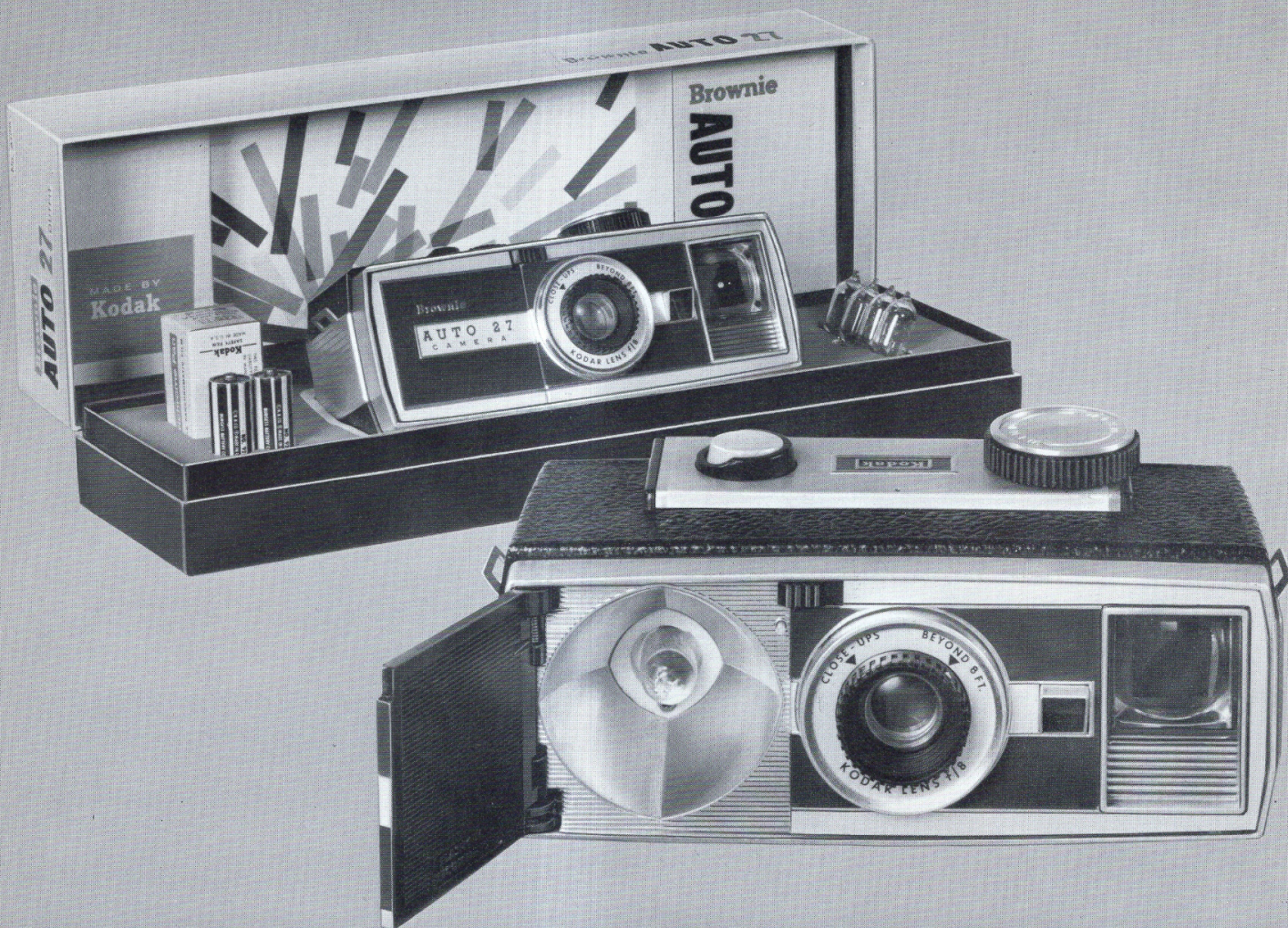

## No. A10K BROWNIE Auto 27 Outfit, \$34.50

### Major Camera Features

- **Sales-winner** for the customer who wants automatic electric-eye convenience and brilliant picture sharpness at low cost.
- **Selling features:** Automatic electric-eye daylight exposure control **plus** automatic focus-linked flash exposure control.
- **Selling points:** Automatic correct exposure with both daylight and flash. Modern CdS electric-eye system. Sure-grip shape and color-corrected  $f/8$  lens for clear, sharp shots — color or black-and-white snaps, or color super-slides. Built-in flashholder. Compact, lightweight, smart styling.
- **Outfit includes:** Camera, adjustable neck strap, flashguard, 4 AG-1 flashbulbs, 2 AA-size batteries, and roll of VP127 film.

No. 36FC BROWNIE Super 27 Field Case \$4.75



## No. 33A KODAK RETINETTE 1A Camera, \$48.50

KODAK RETINA Camera precision and styling at a budget price!

### Major Features

- Fast, coated 45mm  $f/2.8$  lens — for extra sharp pictures.
- Focuses 3 feet to infinity.
- Symbols for close-ups, groups, scenes — easy to set.
- Click-in shutter settings —  $1/30$  to  $1/250$ , and B.
- Synchronized for popular flash bulbs and electronic flash.
- Built-in self-timer — 10 seconds delay.
- Big, bright finder with luminous projected frame.
- Fast single-stroke film advance lever.
- Smart continental styling, beautiful finish.

No. 33FC KODAK RETINETTE 1A Field Case \$9.95

No. C100F KODAK EKTAMITE Flashholder (w/case) \$5.95

# KODAK COLOR FILM

## FILM SPEED AND KODAK FILTER NUMBER

For Still Cameras	Daylight		Flash		Photoflood		3200 K Tungsten		Electronic Flash	Processing
	Speed	Filter	Bulb	Filter	Speed	Filter	Speed	Filter	Filter	
<b>KODACHROME II (KR)</b> Daylight or blue flash For color slides*	25	None	Blue†	None	12	80B	Not recom.		None§	Process K-12 Processed by Kodak and other labs. Sent to Kodak by dealers or direct by users with KODAK Prepaid Processing Mailers.
<b>KODACHROME-X (KX)</b> Daylight or blue flash For color slides*	64	None	Blue†	None	25	80B	Not recom.		None§	
<b>KODACOLOR (C)</b> Daylight or clear flash For color prints¶	32	None	Clear	None	20	82A	16	82C	85§	Process C-22 Processed by Kodak, other labs, or users. Sent to Kodak by dealers or direct by users with KODAK Prepaid Processing Mailers.
<b>KODACOLOR-X (CX)</b> Daylight or clear flash For color prints¶	64	None	Clear	None	40	82A	32	82C	85§	
<b>EKTACHROME-X (EX)</b> Daylight or blue flash For color slides*	64	None	Blue†	None	25	80B	Not recom.		None§	Process E-2 Processed by Kodak, other labs, or users. Sent to Kodak by dealers or direct by users with KODAK Prepaid Processing Mailers.
<b>High Speed EKTACHROME, Daylight (EH)</b> Daylight or blue flash For color slides*	160	None	Blue†	None	Not recom.		Not recom.		None§	
<b>High Speed EKTACHROME, Type B (EHB)</b> Indoor existing light (tungsten) For color slides*	80	85B	Clear	81C	100	81A	125	None	85B§	
<b>For Movie Cameras</b>										
<b>KODACHROME II, Daylight (KR)</b> For full-color movies	25	None	—	—	12	80B	—		—	Process K-12 Processed by Kodak and other labs. Sent to Kodak by dealers or direct by users with KODAK Prepaid Processing Mailers.
<b>KODACHROME II, Type A (KRA)</b> Photoflood lamps For full-color movies	25	85	—	—	40	None	—		—	

\*Must be processed into slides before prints can be made.

¶Must be developed to negatives before prints or slides can be made.

†Or clear bulbs with No. 80C Filter.

§See Film Instructions.

## KODAK BLACK-AND-WHITE FILM For Still Cameras

FILM NAME	PURPOSE	ASA SPEED	FILM NAME	PURPOSE	ASA SPEED
<b>VERICHROME PAN (VP)</b>	All-round use, daylight or clear flash.	125	<b>TRI-X PAN (TX)</b>	Limited light, fast action.	400
<b>PLUS-X PAN (PX)</b>	General use, daylight or clear flash.	125	<b>PANATOMIC-X (FX)</b>	Fine grain for extreme enlargement.	40

## KODACOLOR DEVELOPING AND PRINTING

### KODAK SERVICES THROUGH DEALERS

Type of Service	List
Kodacolor Film Developing . . . . . per roll	\$.90‡
Prints 3R (3½ x 5 to 5¼ in.) from standard-size rectangular negatives. . ea.	.29‡
Prints 3S (3½ x 3½ in.) from 126, 127, 120, and 620 square negatives. . ea.	.25‡
Prints 2R (2½ x 3½ in.) from standard 135 and 828 negatives only. . . . . ea.	.17‡

‡Above prices are for developing and printing when ordered together or when 8 or more prints of one size are ordered. For developing only, add \$.10 per roll. For 1 to 7 prints only, add \$.03 per print.

### KODAK PREPAID PROCESSING MAILERS

For Develop and Print Orders

Mailer Iden. No.	Prints		List Dev. and Print
	No.	Size	
DP8	8	3R	\$3.20
DP12	12	3S	3.90
DP20-2R	20	2R	4.30
DP20-3R	20	3R	6.70

Prices are Kodak list prices, subject to change without notice, and suggested prices only. They include applicable Federal Tax.

# Kodak COLOR SERVICES



**KODACOLOR-X Roll Film**  
620, 120, 616, 116,  
828 and 127 sizes.  
Speed 64



**KODACOLOR-X Film**  
20-exposures.  
Speed 64

**KODACOLOR**  
Negative

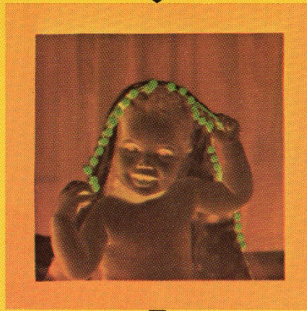

Also available  
31mm  
square from  
 $1\frac{5}{8} \times 1\frac{5}{8}$   
or  $2\frac{1}{4} \times 2\frac{1}{4}$   
negatives

**Kodacolor**  
TRANSPARENCY



MADE BY  
**Kodak**



**KODACOLOR**  
Negative



**KODACOLOR Print 3S**  
from square negatives on 127,  
620 and 120 films

**KODACOLOR Print 3R**  
from Rectangular Negatives

Look for "Processed by Kodak"  
on your color slides,  
"Made by Kodak" on the back  
of your color prints.

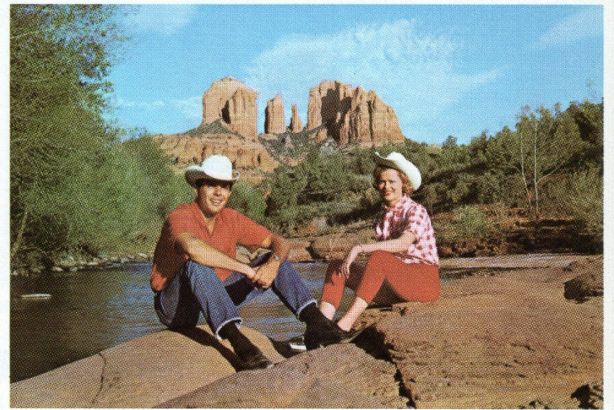

**KODACOLOR Print 2R**

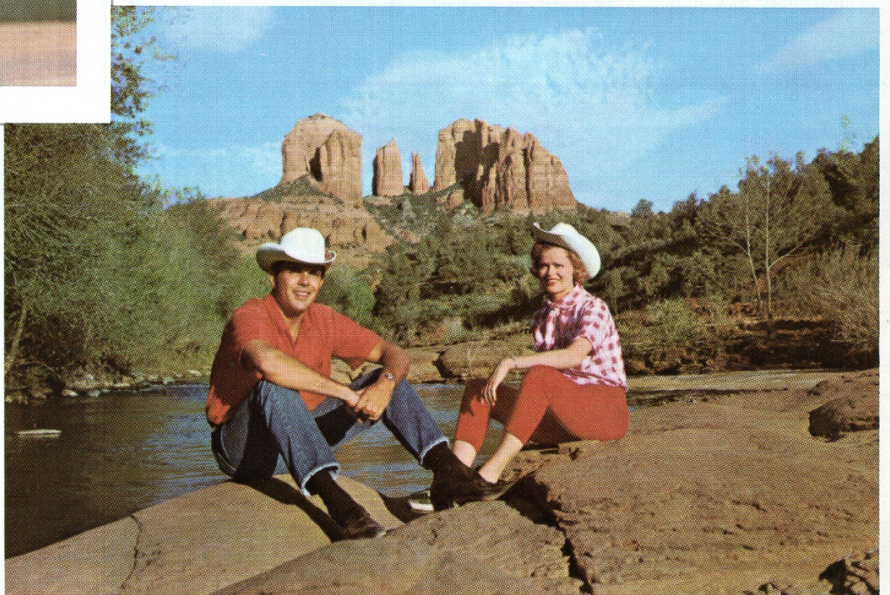



**KODACHROME II** Film,  
20 and 36 exposures.

Speed 25

**KODACHROME-X** Film,  
20 and 36 exposures.

Speed 64



**EKTACHROME-X** Film,  
20 and 36 exposures.

Speed 64

High Speed  
**EKTACHROME** Film,  
20 and 36 exposures.  
Daylight type — 160  
Type B — 125

**EKTACHROME-X** Roll Film,  
620, 120, 127 and 828 sizes.

Speed 64



**Kodachrome**  
TRANSPARENCY



PROCESSED BY **Kodak**

**EKTACHROME**  
TRANSPARENCY



PROCESSED BY **Kodak**

**EKTACHROME**  
TRANSPARENCY



PROCESSED BY **Kodak**



**KODACHROME** Print 2R



**KODACHROME** Print 3S



**KODACHROME** Print 3R

**KODACOLOR** and **KODACHROME**  
Enlargements 5 x 7 to 11 x 14 inches  
are also available

Color services for films  
used in **KODAK INSTAMATIC** Cameras  
are shown on back page.

Roll-Film Cameras	Exposures	Negative Size	Film Size	LIST				
				VP	TX	FX	C & CX	EX
No. 1A KODAK; No. 2A Box or Folding BROWNIE; and others	8	2½" x 4¼"	116	\$.80	—	—	\$1.75	—
For cameras taking 16 pictures on KODAK 120 Film	16	1½" x 2¼"	120	.60	\$.70	\$.70	1.25	\$1.35
For cameras taking 12 pictures on KODAK 120 Film	12	2¼" x 2¼"						
No. 1 KODAK; No. 2 Box or Folding BROWNIE; and others	8	2¼" x 3¼"	122	1.20	—	—	—	—
No. 3A KODAK or BROWNIE; and others	6	3¼" x 5½"						
For cameras taking 16 pictures on KODAK 127 Film	16	1¾" x 1⅞"	127	.60	.70	—	1.25	1.35
BROWNIE STARLET, STARFLEX, STARFLASH, STARMATIC, STARMITE, STAR-METER, FIESTA, SUPER 27, Auto 27, Reflex; KODAK World's Fair Flash; and others	12	1½" x 1½"						
BROWNIE HOLIDAY; BROWNIE 127; Baby BROWNIE; No. 0 BROWNIE; BULLETT; Vest Pocket; and others	8	1½" x 2½"						
For cameras taking 16 pictures on KODAK 616 Film	16	2½" x 2½"	616	.80	—	—	1.75	—
Vigilant Six-16; Monitor Six-16; Senior Six-16; Junior Six-16; BROWNIE TARGET Six-16; BROWNIE Six-16; HAWK-EYE Six-16; KODAK Six-16; and others	8	2½" x 4¼"						
Duo Six-20; Duex; and others	16	1½" x 2¼"	620	.60	.70	.70	1.25	1.35
DUAFLEX; BROWNIE Reflex 20, Flash 20, Twin 20, FLASHMITE 20; BROWNIE HAWKEYE; KODAK Reflex; CHEVRON; and others	12	2¼" x 2¼"						
BROWNIE BULL'S-EYE; TOURIST; Medalist; BULL'S-EYE Six-20; Vigilant Six-20; Monitor Six-20; Senior Six-20; Junior Six-20; KODAK Six-20; BROWNIE TARGET Six-20; BROWNIE Six-20; and others	8	2¼" x 3¼"						

Miniature Cameras	Exposures	Negative Size	Film Size	LIST									
				KR	KX	CX	C	EX	EH	EHB	VP	PX	TX-FX
KODAK INSTAMATIC 100, 300, 400, 500, 700, 800	12	28 x 28mm	126	—	—	\$1.40	—	—	—	—	\$.75	—	—
	20	28 x 28mm		—	\$2.15	—	—	\$2.35	—	—	—	—	—
PONY II, IV, 135; SIGNET; Automatic 35; MOTORMATIC 35; RETINETTE; RETINA; EKTRA; KODAK Stereo; and other cameras designed to use standard 35mm film magazines. Use only KR, KX, EX, EH(B) for stereo.	20	24 x 36mm	135	\$2.15	2.35	1.95	—	2.35	\$2.75	\$2.75	—	\$.95	\$.95
	36	24 x 36mm		3.10	3.40	—	—	3.40	3.95	—	—	1.25	1.25
PONY 828; BANTAM; BANTAM RF; and other cameras using KODAK 828 Film	8	28 x 40mm	828	1.05	—	1.00	\$1.00	1.15	—	—	.60	—	—

Movie Cameras	Film Size	Identification Number		List
		Daylight	Type A	
BROWNIE and KODAK Movie; BROWNIE Movie Turret; RELIANT; and other 8mm spool-type cameras	8mm 25' roll	KR459	KRA459	\$2.65
CINE-KODAK MEDALLION 8; CINE-KODAK Magazine 8; and other 8mm magazine cameras	8mm 25' mag	KR460	KRA460	4.50†
CINE-KODAK K-100; CINE-KODAK Special; CINE-KODAK, Model K; and other 16mm spool-type cameras	16mm 100' roll	KR449	KRA449	9.95
CINE-KODAK ROYAL Magazine; CINE-KODAK Magazine 16; and most other 16mm magazine cameras	16mm 50' mag	KR447	KRA447	7.65†
†Includes magazine deposit: \$.50 for 8mm and \$.85 for 16mm.				

## KODACHROME AND EKTACHROME PROCESSING

OF FILMS FOR STILL CAMERAS					
KODACHROME and EKTACHROME Films		Processing and Mounting	Unmounted	Prepaid Processing Mailer	
Size	No. of exp.			List	Iden.
135-20	20	\$1.85	\$1.60	PK20	\$1.85
135-36	36	3.05	2.65	PK36	3.05
126	20	1.85	1.60	PK20	1.85
828	8	1.20	1.10	PK28	1.20
127	12	1.85	1.60	PK27	1.85
120, 620	12	1.85	1.60	—	—
127, 120, 620	8 or 16	—	1.60	—	—

OF FILMS FOR MOVIE CAMERAS			
KODACHROME Film	Processing Charge	Prepaid Processing Mailer	
		Size	List
8mm 25' roll	\$1.85	PK59	\$1.85
8mm 25' mag	1.50†	PK60	1.50†
16mm 100' roll	4.50	PK49	4.50
16mm 50' mag	1.85†	PK47	1.85†
†After refund of magazine deposit: \$.50 for 8mm and \$.85 for 16mm.			

Prices are Kodak list prices, subject to change without notice, and suggested prices only. They include applicable Federal Tax.

# KODAK 35mm AUTOMATICS

## No. 71 KODAK Automatic 35F Camera, \$99.50

New pop-up flashholder . . . automatic flash control . . . fully-automatic electric-eye control . . . in a new model of the famous KODAK Automatic 35 Camera.



### Major Features

- New built-in pop-up flashholder uses AG-1 bulbs . . . plus automatic flash control that sets lens opening as you focus.
- Maximum aim-and-shoot simplicity outdoors . . . fully-automatic electric-eye control sets lens opening.
- Fast  $f/2.8$  lens and 4 shutter speeds to  $1/250$  second.
- Automatic "focus minder" in viewfinder for close-ups, groups, scenes . . . reminds you before you shoot.
- Rapid single-stroke film advance . . . dim-light signal . . . automatic leader wind-off . . . double-exposure prevention.

No. 71FC KODAK Automatic 35F

Field Case \$12.50

## No. 72 KODAK MOTORMATIC 35F Camera, \$119.50

"Most complete automatic of the automatics" . . . winds film for you . . . sets lens for you . . . sets flash exposure as you focus . . . and now with a new pop-up flashholder built in!



### Major Features

- New pop-up flashholder built in for AG-1 bulbs. Folds flat when not in use!
- Automatic flash exposure control — focusing sets lens opening!
- Fully automatic outdoor exposure — electric eye sets lens opening for you!
- Spring-power drive — up to 10 shots at one winding — 10 shots in 10 seconds, if you choose!
- Fast  $f/2.8$  lens — shutter speeds  $1/40$  second to  $1/250$ !
- Automatic "focus minder" — shows in finder when focused for close-ups, groups, scenes!
- Other features same as the Automatic 35F!

No. 72FC KODAK MOTORMATIC 35F

Field Case \$12.50

# Precision RETINA Cameras

## No. 269 KODAK RETINA Automatic III Camera, \$139.50

Fully-automatic electric eye . . . sets lens opening at all shutter speeds . . .  
plus precision lens-coupled rangefinder—viewfinder.



### Major Features

- Fully automatic exposure at shutter speeds 1/30 to 1/500 second: you select.
- Positive stop—no under- or overexposure errors.
- Manual exposure control when desired.
- Precision coupled rangefinder—no focusing errors.
- Fast, coated f/2.8 lens focuses to 3 1/2 feet, stops down to f/22.
- Synchronization for all popular flash bulbs and electronic.
- Rapid single-stroke film advance.

No. 269FC KODAK RETINA Field Case, Model E \$12.00  
No. C100F KODAK EKTAMITE Flashholder (w/case) \$5.95

## No. 270 KODAK RETINA Reflex III Camera, f/2.8, \$229.50

## No. 271 KODAK RETINA Reflex III Camera, f/1.9, \$263.50

Automatic control now also visible in viewfinder!



### Major Features

- New dual photoelectric exposure control:
  1. Meter needle on top of camera—direct lens setting!
  2. Meter needle also in finder—direct setting while viewing!
- Big, bright parallax-free pentaprism viewing!
- Full-area ground glass *plus* precision range-finder focusing!
- Automatic diaphragm — stops down as you shoot!
- Shutter-speed lens-opening linkage—keeps correct exposure!
- Automatic field-depth indicator — moves with diaphragm!
- Ultra-steady body shutter release with safety lock!
- Big viewfinder eyepiece — easier to use when wearing glasses!

No. 270FC KODAK RETINA Field Case, Model F (for f/2.8 Model) \$14.50  
No. 271FC KODAK RETINA Field Case, Model G (for f/1.9 Model) \$17.50  
No. C100F KODAK EKTAMITE Flashholder (w/case) \$5.95

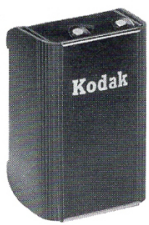

**C60C**

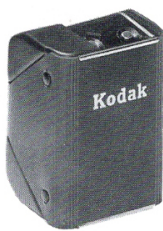

**C65C**



**C70C**

**No. C60C KODAK INSTAMATIC Field Case, Model A** ..... \$4.50  
For KODAK INSTAMATIC 100 Camera. Black, high-gloss simulated leather with bright metal trim and hinged front cover.

**No. C65C KODAK INSTAMATIC Field Case, Model B** ..... \$4.95  
For KODAK INSTAMATIC 300 and 400 Cameras (Similar to Model A).

**No. C70C KODAK INSTAMATIC Field Case, Model C** ..... \$9.95  
For KODAK INSTAMATIC 700 and 800 Cameras. Three-section case styled in satin-finish black with spring hinged cover.

**No. C75C KODAK INSTAMATIC Compartment Case (not shown)** ..... \$16.95



**72FC**



**24C**

**No. 72FC KODAK MOTORMATIC 35F Field Case** ..... \$12.50

**No. 71FC KODAK Automatic 35F Field Case (not shown)** ..... \$12.50

**No. 24C BROWNIE STARFLASH and STARMITE Carrying Case (Also fits World's Fair Flash Camera)** . \$4.25  
Pouch-type carrying case made of simulated leather to protect camera.

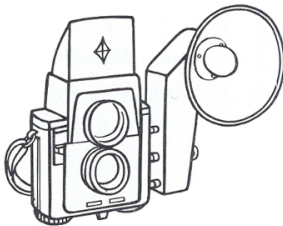
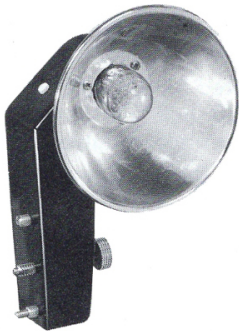

**No. 740 KODALITE Midget Flashholder** ..... \$4.50  
Compact flash holder with 3" reflector accepts M2, M5, M25, No. 5 or 25 bulbs. Uses two AA-size batteries or flashpack (extra).

**No. 749 KODALITE SUPER-M 40 Flashholder (not shown)** ..... \$8.95

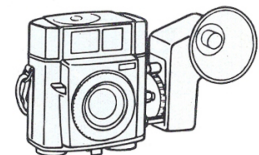
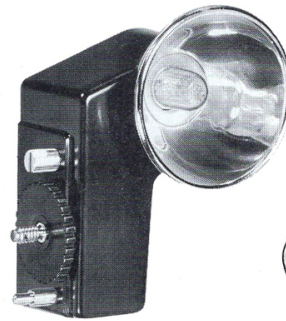

**No. 714 KODAK SUPERMITE Flashholder** ..... \$4.50  
Full-power — small size! Only 3 ounces! 2-inch reflector; with AG-1 bulbs, gives same output as M2 in 3-inch reflector. Exposure guide on back. Accepts two AA-size batteries or a KODALITE Midget B-C Flashpack (extra).

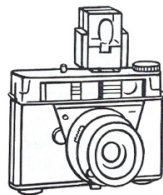

**No. C100F KODAK EKTAMITE Flashholder** ..... \$5.95  
Compact flash holder designed expressly for RETINETTE and RETINA Cameras. Attaches to accessory shoe on top of camera. Accepts AG-1 flash bulbs. Powered by two long-life "N" cells (not supplied). Comes complete with flashguard and carrying case.

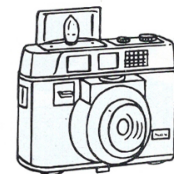
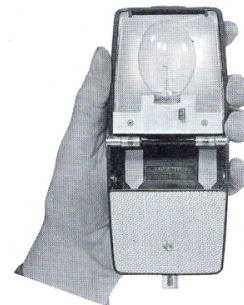

**No. 760 KODAK Electric-Eye Remote Flash Unit** ..... \$19.95  
Low-cost transistorized electric-eye "slave" unit brings new versatility. Self-powered by 3 tiny AAA batteries (not supplied) — needs no hook-up wires. Triggers from camera flash at all normal flash distances. Accepts M2, M5, M25, No. 5 and 25 flash bulbs.



**KODAK Close-up Attachment** ..... \$2.50

For adapting box and other simple-lens-type cameras for close-up picture-taking to 3½ feet. Attachment fits easily over lens for close-ups of people, flowers, and small objects. Each Merchandise Card contains six Attachments of a single size: No. 608/6A, No. 608/7A or No. 608/13.



**KODAK Cloud Filter** ..... \$2.50

For use with simple-type non-adjustable cameras to improve black-and-white snapshots of clouds, marine scenes, and landscapes by darkening blue skies and emphasizing clouds. Each Merchandise Card contains six filters of a single size: No. 609/6A, No. 609/7A or No. 609/13.

## **No. 503 KODAK READYMATIC 500 Projector, \$69.95**

Instant editing . . . smooth push-pull changing . . . 500-watt power . . . in a handsome, rugged, self-cased, budget-priced projector.

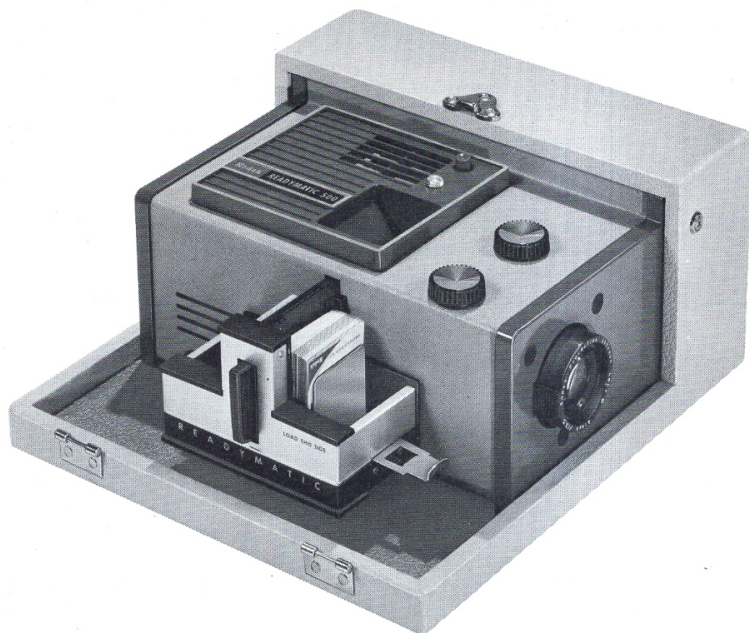

### **Major Features**

- Instant editing . . . push a button and slide pops up for removal.
- Smooth-action improved KODAK READYMATIC Changer . . . handles up to 36 cardboard 2 x 2 slides at one loading. No trays to buy.
- Gate accepts single slides in glass mounts.
- 500-watt power, high-efficiency condensers, heavy heat-absorbing glass for slide projection.
- Sharp color-corrected KODAK EKTANON 4-inch  $f/3.5$  Lens. (3-inch, 5-inch, and 7-inch rack-focusing lenses also available.)
- Sturdy, handsome self-case, with Preview Screen in case cover.

## **KODAK CAROUSEL Projector, Model 550**

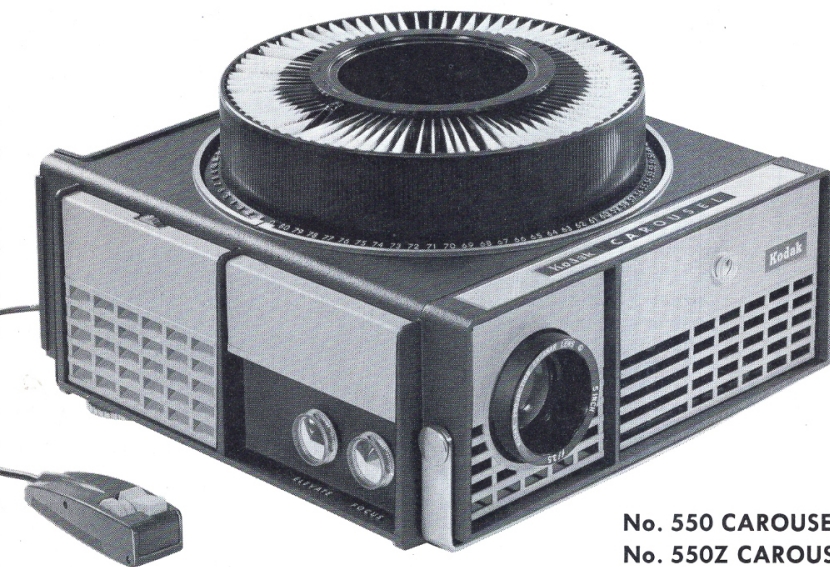

- **Sales-winner** for customers who want the finest in an automatic projector for 2 x 2 slides.
- **Selling feature:** Most dependable of all automatic systems.
- **Selling point:** 80-slide long-play round trays. 5, 10, & 20 sec. automatic timing. Full-range remote control — forward, reverse, focus. Instant access to every slide for editing. Trays change like a hi-fi record, store like a book, 500-watt power, with hi-lo switch. Rugged die-cast construction; handsome!

No. 550 CAROUSEL 550 with 5-inch  $f/3.5$  lens \$149.50

No. 550Z CAROUSEL 550 with  $f/3.5$  ZOOM lens \$179.50

Other models available with 3-, 4-, 5- and 7-inch lenses.

No. 583C KODAK Carrying Case for KODAK CAROUSEL Projector \$10.95

No. 586 KODAK Remote Extension Cord, 25-foot \$4.25

No. 581 KODAK CAROUSEL Slide Tray \$2.95

No. 582 KODAK Carrying Case for KODAK CAROUSEL Slide Trays \$10.95

# KODAK and BROWNIE Movie Cameras



## No. D10S BROWNIE FUN SAVER Movie Camera, \$19.95 (with Film and Idea Book)

- **Sales-winner** for the many families who would like to have their own personal movies, but feel they are too complicated or too expensive.
- **Selling feature:** A quality movie camera made by Kodak for "Less than \$20," in complete outfit.
- **Selling points:** Only one simple setting for full-color 8mm movies. Fast  $f/2.7$  lens. Quick, easy loading. Footage meter resets automatically after loading. Fast crank wind of motor. Enclosed optical viewfinder. Accepts KODAK 8 Movie Light for indoor movies or KODAK Sun Gun Movie Light, Model 1.
- **Package includes:** BROWNIE FUN SAVER Movie Camera, a roll of KODACHROME II Movie Film, and a copy of the easy-to-read book, "How to Make Good Home Movies."

No. D350 KODAK Pistol Grip \$2.50

No. 143FC KODAK Field Case for KODAK ESCORT 8, Automatic 8,  
and BROWNIE FUN SAVER Movie Camera \$6.95

No. 793 KODAK 8 Movie Light, Model 1 \$5.95

No. D371 KODAK Sun Gun Movie Light, Model 1 \$19.95

## No. 148 KODAK 8 Movie Camera, $f/1.9$ , \$34.50

Just one simple setting required for 8mm movie-making! Smart black styling . . . fumble-free loading . . . subjects automatically in focus from few feet to infinity.



### Major Features

- New lens opening system allows continuous adjustment from  $f/1.9$  to  $f/19$  by rotating lens hood.
- Enclosed optical viewfinder makes it easy to frame scenes.
- Fast crank wind-up for ever-ready shooting.
- Wide shutter release bar for steady shooting.
- No focusing necessary for clear pictures from a few feet away to distant scenes.
- Accepts compact KODAK 8 Movie Light (extra) for ideal "over-the-camera" illumination.
- Exposure guide on side of camera indicates proper lens opening setting for various light conditions using KODACHROME or KODACHROME II Films.

No. D350 KODAK Pistol Grip \$2.50  
No. 148FC KODAK Field Case \$6.95  
No. 793 KODAK 8 Movie Light, Model 1 \$5.95  
No. D371 KODAK Sun Gun Movie Light \$19.95

## No. 145 KODAK Zoom 8 Automatic Camera, \$119.50

Features new focusing  $f/1.6$  zoom lens . . . sturdy die-cast construction.



### Major Features

- Zoom shots — 9mm to 25mm wide-angle and telephoto — are easily made by turning outer sleeve of lens barrel. Lens can also be set at any position.
- Viewfinder is coupled to lens so user sees the zoom action.
- The  $f/1.6$  zoom lens can be set for any distance from 6 feet to infinity, for extra-sharp movies.
- Electric eye automatically sets the lens to any light condition — indoors or outdoors.
- Low-light indicator visible in viewfinder.
- Dial adjusts electric-eye meter for film exposure indexes 10 to 40.
- Built-in "Type A" filter (pointer shows in viewfinder when filter is in position). Permits user to shoot outdoors as well as indoors on the same roll of 8mm KODACHROME Film.
- Fast crank wind. Camera runs 10 feet of film on one winding.
- Accepts KODAK 8 Movie Light (extra) for ideal "over-the-camera" illumination.

No. 145FC KODAK Field Case \$6.50  
No. 793 KODAK 8 Movie Light, Model 1 \$5.95



## No. D20 KODAK ESCORT 8 Camera, \$54.50

Newly-styled fully automatic movie camera

Here's a newly-styled automatic 8mm movie camera at a budget price. Indoors or outdoors, the built-in electric eye automatically and continuously adjusts the lens. Fast  $f/1.6$  lens is always in focus.



Electric eye sets the lens automatically—signals when light is too dim for good movies.

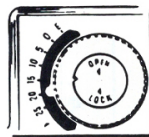

Footage meter re-sets automatically.



KODAK 8 Movie Light (No. 793) attaches to top of camera for easy indoor movies. (Extra \$5.95.)

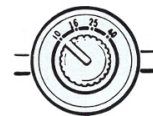

Dial on side of camera adjusts the electric-eye meter for film speeds 10, 16, 25 and 40.

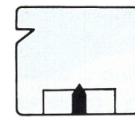

Arrow visible in viewfinder tells when built-in Type A filter is in position. Filter lets you shoot indoors or outdoors on the same roll of KODACHROME II Film, Type A.

No. D350 KODAK Pistol Grip \$2.50

No. 143FC KODAK Field Case \$6.95

No. D371 KODAK Sun Gun Movie Light, Model 1 \$19.95

No. D793 KODAK 8 Movie Light, Model 1 \$5.95



## No. D23 KODAK ESCORT 8 Zoom Camera, \$99.50

Automatic 8mm zoom model at a new low price

One merely rotates the lens barrel as he shoots, to make exciting zoom shots. Or, the lens can be set in advance at any position from wide-angle to telephoto close-up. This is the fastest zoom lens on the market today.



Comes with 9 to 27mm focusing  $f/1.6$  zoom lens. Focuses from 6 feet to infinity, or can be left on the red diamond mark for fixed-focus operation.

You see the zooming action as it happens through the enclosed bright viewfinder.



The electric-eye meter automatically sets the lens opening to any light condition—indoors or out. Signal appears in viewfinder when the light is too dim to shoot good movies.

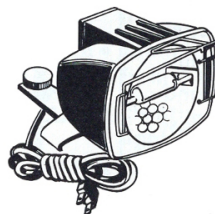

Camera accepts the No. D371 KODAK Sun Gun Movie Light, Model 1, for indoor shooting. (Extra \$19.95.)

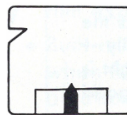

A pointer visible in the finder reminds user when the built-in Type A filter is in position.

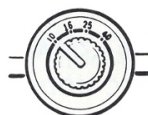

Film speed dial adjusts electric eye for film speeds 10, 16, 25 and 40.

No. D350 KODAK Pistol Grip \$2.50

No. 145FC KODAK Field Case \$6.50

No. 793 KODAK 8 Movie Light \$5.95

## No. 306 KODAK Electric 8 Automatic Camera, \$99.50

Battery driven (no winding) . . . instant cassette loading



- **Sales-winner** for the customer who wants a quality 8mm movie camera with the convenience of quick, cassette loading and battery drive.
- **Selling feature:** No conventional threading. No winding.
- **Selling points:** Drop-in cassette loading. Battery driven. Electric-eye meter automatically and continuously sets lens opening. User can adjust meter plus or minus  $\frac{1}{2}$  stop when desired. Camera lens can be locked at any opening. Meter can be set for film speeds 10 to 40. At the new 16A and 40A settings, the Type A filter is automatically positioned and the meter set for using Type A color film outdoors. Remote control outlet. Single-frame control.
- **Camera comes with** fast  $f/1.6$  fixed-focus lens, hand strap, and one KODAK DUEX 8 Cassette.

No. D350 KODAK Pistol Grip \$2.50

No. D300C KODAK Compartment Case for  
KODAK Electric 8 Cameras \$14.95

## No. 307 KODAK Electric 8 Zoom Camera, \$159.50



- **Sales-winner** for customers wanting an 8mm zoom movie camera with latest features.
- **Selling feature:** Zoom model with new drop-in cassette loading.
- **Selling points:** 9 to 27mm  $f/1.6$  focusing zoom lens. Drop-in cassette loading. Battery driven. Electric-eye meter automatically and continuously sets lens opening. User can adjust meter plus or minus  $\frac{1}{2}$  stop when desired. Camera lens can be locked at any opening. Meter can be set for film speeds 10 to 40. At the new 16A and 40A settings, the Type A filter is automatically positioned and the meter set for using Type A color film outdoors. Remote control outlet. Single-frame control.
- **Camera comes with** pistol grip, neck strap, hand strap and one KODAK DUEX 8 Cassette.

No. D300C KODAK Compartment Case for  
KODAK Electric 8 Cameras \$14.95

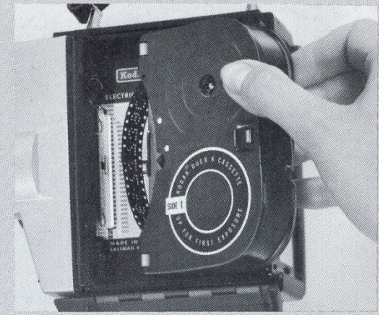

#### Drop-in cassette loading

New KODAK DUEX 8 Cassette uses regular 8mm roll film, but eliminates conventional threading. Several cassettes may be preloaded for continuous filming. Cassette quickly snaps into place. User merely flips it over at end of first 25 feet to expose second side.



#### New 8-to-1 zoom lens

Enlarges objects in scene up to 8 times. Makes smooth zoom shots from 6.5 to 52mm. User focuses through the lens—from less than 3 feet to infinity.

## No. D45 KODAK Electric 8 Zoom Reflex Camera, \$295

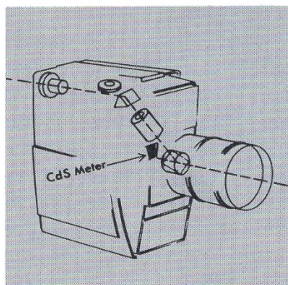

#### Zoom reflex viewfinder

Telescopic finder that lets user see exactly what will be recorded on the film, including zooming action.

#### Battery-powered electric eye

CdS meter is extremely sensitive, and is set in the lens system to see what the lens sees. Automatically sets the lens opening for correct exposure. (Meter can be set for ASA film speeds 10 to 40.) Lens can be locked at any opening.

#### Complete manual override

User can set lens opening manually when desired.

#### Lens—

6.5 to 52mm  $f/1.8$  focusing zoom.



#### Battery-driven

No winding, ever! Four AA-size batteries (extra) run the camera. Signal in finder tells when to change batteries.

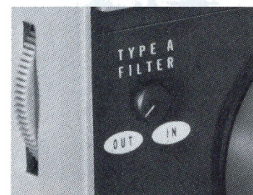

#### Built-in filter

Type A filter for exposing indoor color film outdoors. It is not necessary to change the film speed setting when filter is placed in position.

- Adjustable eyepiece to meet individual eye requirements.
- Lens openings, ASA film speeds, and low-light-level indicator visible in viewfinder.
- Exposure bar can be set for continuous run or single frame, or can be locked to prevent accidental exposure.
- Film plane shown on side of camera for critical focusing.

## **No. 215 BROWNIE 8 Movie Projector (Model A15),**

Threads itself automatically . . . right onto the take-up reel.

**\$54.50**

## **No. 215/208C BROWNIE 8 Movie Projector (Model A15)**

**with KODAK Carrying Case, \$59.95**

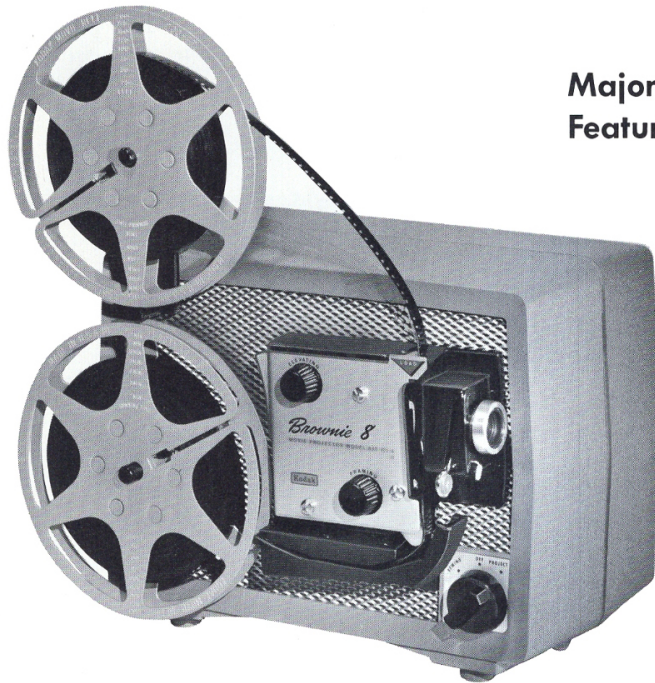

### **Major Features**

- Completely automatic threading.
- New projection lamp with built-in reflector provides extra-bright 8mm screenings up to 4 feet wide.
- Compact and lightweight: easy to carry, weighs only 6 pounds.
- "Big-screen"  $f/1.6$  lens.
- Fast, easy elevation — only the optical center moves.
- Single control for forward projection, power rewind, 200-foot reel for 15-minute showings.
- Never needs oiling.

**No. 208C KODAK Carrying Case for BROWNIE 8 Movie Projectors \$6.95**

## **No. 238 KODAK Automatic 8 Projector, Model 1, \$109.50**

Threads . . . projects . . . rewinds—all automatically

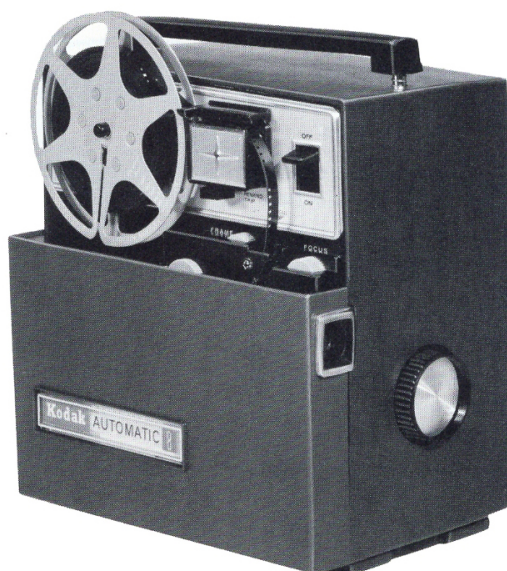

### **Projector Features**

- Fully automatic threading, right onto take-up reel
- At the end of reel, projector turns projection lamp off and room light on, automatically rewinds film, and then shuts off motor
- Rewinds 50-foot reel in approximately 10 seconds; 200-foot reel in approximately 20 seconds
- Has enclosed, permanent 200-foot take-up reel
- Control for forward, reverse, and "still" projection
- DCH lamp and  $f/1.6$  lens provide bright screenings
- Never needs oiling
- Projector comes with supply of KODAK Rewind Film Clips, which user can easily attach to any roll or reel of processed film to provide automatic rewinding
- Built-in case construction

**No. D510 KODAK Rewind Film Clip . . . package of 10 \$4.40**

## No. 280 KODAK CHEVRON 8 Projector, Model 1, \$149.50

## No. 280Z KODAK CHEVRON 8 Projector, Model 1 (with zoom lens) \$174.50

Fully automatic 8mm model with overhead geared reel arms



### Projector Features

- Modern, low-format design
- Fully automatic threading right onto overhead take-up reel
- 400-foot reel capacity for half-hour showings. Unique storage space for take-up reel in projector base
- Control for forward and reverse projection, bright "stills" and power rewind
- "Normal-bright" lamp switch
- Variable-speed control
- Special motor mounting and 45° pulldown system provide extremely quiet operation
- Comes with KODAK 22mm f/1.2 EKTANAR Lens with integral field flattener for sharper images edge-to-edge
- Room-light receptacle (the room light, when plugged into the projector, is automatically controlled as the projection lamp is switched on and off)
- 3-position control for longer lamp life
- Removable 10-foot power cord stores in cover
- Removable cover is held to case with magnetic clasps
- Operates on 110-125 volts, 60-cycle AC. Never needs oiling.

## KODAK CHEVRON 8 Projector, Model 10

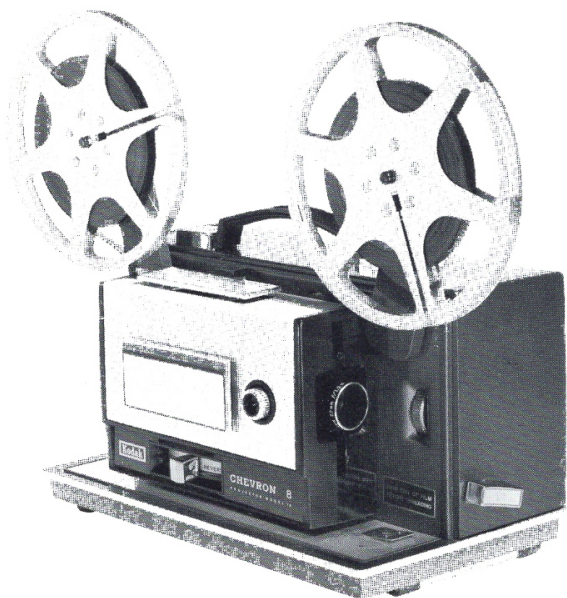

### Projector Features

- **Sales-winner** for customers wanting the finest in a silent 8mm projector
- **Selling feature:** Extra-bright "still" projection and slow-motion projection
- **Selling points:** Same as for the standard KODAK CHEVRON 8 Projector, plus
- Same brilliant illumination for "stills" as for normal running speed.
- Slow motion — instantly at the flip of a lever (variable speeds 7 1/2 to 10 1/2 fps and 15 to 21 fps)

No. 281 with 22mm f/1.2 lens \$189.50

No. 281Z with f/1.2 zoom lens \$214.50

No. 282 with 22mm f/1.0 lens \$214.50

No. 275 KODAK ANALYST 8 Projector, A75 \$295.00

# KODAK Movie Aids



## Movie Aids for KODAK Electric 8 Automatic Camera

- No. D350 KODAK Pistol Grip (for all KODAK Movie Cameras) ..... \$ 2.50
- \*No. D355 KODAK Carrying Handle (for all KODAK Movie Cameras, except KODAK Electric 8 Cameras) ..... \$ 2.95
- No. D356 KODAK Neck Strap (for KODAK Electric 8 Cameras; with KODAK Carrying Handle, fits other KODAK Movie Cameras) ..... \$ 3.50
- No. D360 KODAK DUEX 8 Cassette (for KODAK Electric 8 Movie Cameras) ..... \$ 4.95
- No. D351 KODAK Remote Control Cord, 25-foot (for KODAK Electric 8 Movie Cameras) ..... \$ 4.95

- \*No. D371 KODAK Sun Gun Movie Light, Model 1 (for all KODAK Movie Cameras except KODAK Electric 8 Cameras) ..... \$19.95
- No. D372 KODAK Sun Gun Movie Light, Model 2 (for KODAK Electric 8 Movie Cameras; with KODAK Carrying Handle, fits other KODAK Movie Cameras) ..... \$21.95
- AA-Size Batteries, Manganese Alkaline, each ..... \$ .50
- No. D300C KODAK Compartment Case (for KODAK Electric 8 and Electric 8 Zoom Camera; not for Electric 8 Zoom Reflex Camera) ..... \$14.95



- No. 793 KODAK 8 Movie Light (Model 1) ..... \$5.95
- Fits on top of the BROWNIE FUN SAVER, KODAK 8, ESCORT 8, and KODAK ESCORT 8 Zoom Cameras. Accepts 300- or 375-watt reflector flood lamps (extra).
- 300-watt lamp (ASA code BEP) ..... \$ .93
- 375-watt lamp (ASA code BFA) ..... \$1.45

- No. 791 KODAK 3-Lamp Movie Light (Model 1) ..... \$7.50
- Fits all KODAK Movie Cameras. Accepts 300- or 375-watt reflector flood lamps (extra).

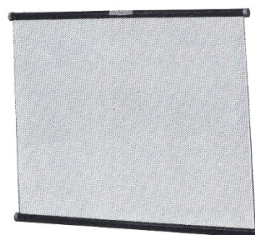
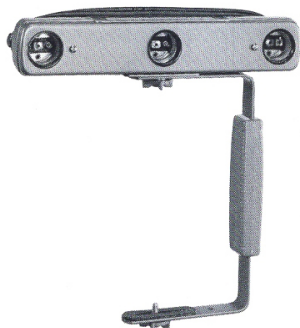

- No. 337 BROWNIE Projection Screen (22 x 30 inches) ... \$ 5.95

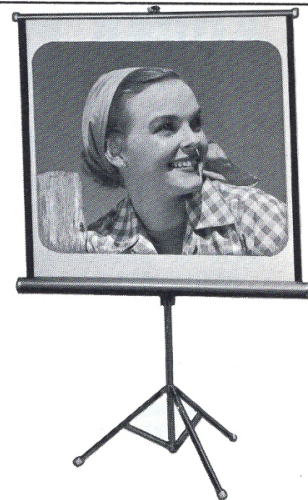

- No. 338 KODAK Projection Screen (40 x 40 inches) ... \$16.95

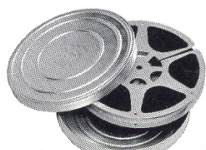

- KODAK Movie Reels and Film Cans
- 200-foot 8mm KODAK Movie Reel and Can ..... \$1.80
- 400-foot 8mm KODAK Movie Reel and Can ..... \$2.55
- 400-foot 16mm KODAK Movie Reel and Can ..... \$2.95

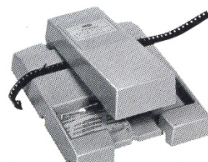

- No. 64 KODAK PRESSTAPE Movie Splicer ..... \$7.50

# KODAK Prepaid Processing Mailers

## For Color Prints

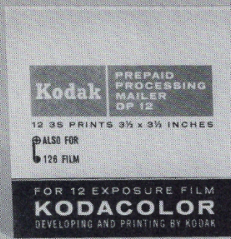

DP12 For KODACOLOR Film (12 exposure rolls)

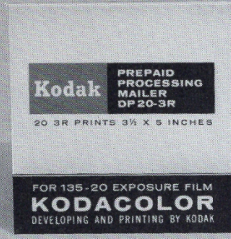

DP20-3R For KODACOLOR Film (35mm — 20 exposure)



PK27 For EKTACHROME Film (127 size — 12 exposure)



PK20 For KODACHROME or EKTACHROME Film (35mm and 126 — 20 exposure)

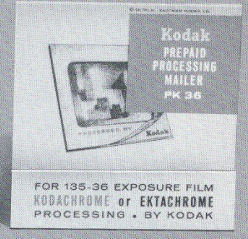

PK36 For KODACHROME or EKTACHROME Film (35mm — 36 exposure)

## For 8mm KODACHROME Movie Film



PK60 — Double 8mm 25 ft. Magazine

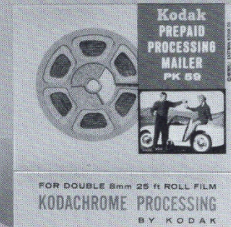

PK59 — Double 8mm 25 ft. Roll



No. 603 KODAK Processing Mailers Assortment

© Eastman Kodak Company MCMLXI

Tell your customers about

## KODAK Prepaid Processing Mailers

The following mailers are available from your usual source of Kodak supplies. Order yours today.

### For Color Slides

**PK28** For KODACHROME, KODACHROME II, EKTACHROME, and EKTACHROME-X Film 828, 8-exp., in mounts . . . . . \$1.20 each

**PK20** For KODACHROME, KODACHROME II, KODACHROME-X EKTACHROME, EKTACHROME-X, and High Speed EKTACHROME Film, 135, 20-exp. in mounts, and KODACHROME-X and EKTACHROME-X, 126, 20-exp., in mounts . . . . . \$1.85 each

**PK36** For KODACHROME, KODACHROME II, KODACHROME-X, EKTACHROME-X, and High Speed EKTACHROME Film 135, 36-exp. (24x 36mm), in mounts . . . . . \$3.05 each

**PK27** For EKTACHROME and EKTACHROME-X Film 127, 12-exp., in mounts . . . . . \$1.85 each

### For 8mm Movie Film

**PK60** For KODACHROME and KODACHROME II Movie Film, 8mm, 25-ft. magazine . . . . . \$2.00  
Refund of magazine deposit . . . . . — .50  
Processing charge after refund . . . . . \$1.50

**PK59** For KODACHROME and KODACHROME II Movie Film, 8mm, 25-ft. roll . . . . . \$1.85 each

### For 16mm Movie Film (not illustrated)

**PK47** For KODACHROME and KODACHROME II Movie Film, 16mm, 50-ft. magazine . . . . . \$2.70  
Refund of magazine deposit . . . . . — .85  
Processing charge after refund . . . . . \$1.85 each

**PK49** For KODACHROME and KODACHROME II Movie Film, 16mm, 100-ft. roll (perforated one or two edges, or for high speed cameras). . . . . \$4.50 each

### For KODACOLOR Prints

**DP8** For any 8-exp. KODACOLOR Film (includes 8 KODACOLOR Prints 3R) . . . . . \$3.20 each

**DP12** For any 12-exp. KODACOLOR Film (includes 12 KODACOLOR Prints 3S) . . . . . \$3.90 each

**DP20-2X** For KODACOLOR and KODACOLOR-X Film 135, 20-exp. Includes 20 KODACOLOR Prints 2R . . . . . \$4.30 each

**DP20-3X** For KODACOLOR and KODACOLOR-X Film 135, 20-exp. Includes 20 KODACOLOR Prints 3R . . . . . \$6.70 each

A convenient way for vacation-minded photo fans and tourists to get prepaid direct-mail processing of their exposed Kodak color films by a Kodak Processing Laboratory. Kodak mails the processed film — mounted slides, prints, or movies — direct to customers' homes.

**Just Right For Impulse-Buying**  
**No. 603 KODAK Processing Mailers Assortment . . .**  
**Retail, up to \$18.50**

**Contents:**  
5—PK20 Prepaid Mailers (\$1.85 each)  
5—PK59 Prepaid Mailers (\$1.85 each)  
Counter Dispenser and Streamer

Prices shown are Kodak list, subject to change without notice, and are suggested prices only.



# KODAK SOUND RECORDING TAPE

Now available on:

- New DUROL Base for extra strength
- New Polyester Base for extended play

REMEMBER—You get each 7-inch roll of tape on the popular KODAK Thread-Easy Reel.

## No. 501 KODAK Sound Recording Tape Assortment

Retail, up to... **\$42.05**

### ADVANTAGES TO YOU . . .

- Sure way to increase your profits and tape business by stocking another quality product made by Kodak.
- Easy to stock and display a balanced assortment of new KODAK Tapes.
- Compact, versatile dispenser designed for shelf, counter or pegboard use.

Price subject to change without notice.

### CONTENTS OF NO. 501 ASSORTMENT

6 rolls 31A1, 150-ft. 3-in. reel  
 3 rolls 11P4, 400-ft. 3-in. reel  
 2 rolls 31A6, 600-ft. 5-in. reel  
 4 rolls 31A12, 1200-ft. 7-in. reel  
 2 rolls 21A18, 1800-ft. 7-in. reel  
 1 roll 11P25, 2500-ft. 7-in. reel  
 Metal Tape Dispenser — no charge  
 25 Folders — no charge  
 Streamer — no charge



# KODAK COLOR SERVICES

for 126 color films used in Kodak Instamatic cameras



KODACOLOR-X Film,  
12-exposure, speed 64.

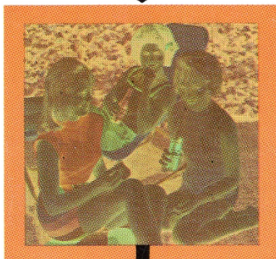

KODACOLOR  
Negative



KODACOLOR Print 3S

KODACOLOR Enlargements up to 11 x 14 in. and KODACOLOR Transparencies in 2 x 2-in. mounts are also available from your color negatives.



KODACHROME-X Film,  
20-exposure, speed 64.



PROCESSED BY **Kodak**



KODACHROME Print 3S

KODACHROME Enlargements up to 11 x 14 in. are also available from your color slides.



EKTACHROME-X Film,  
20-exposure, speed 64.



PROCESSED BY **Kodak**

**EASTMAN KODAK COMPANY, Rochester, N. Y. 14650**