

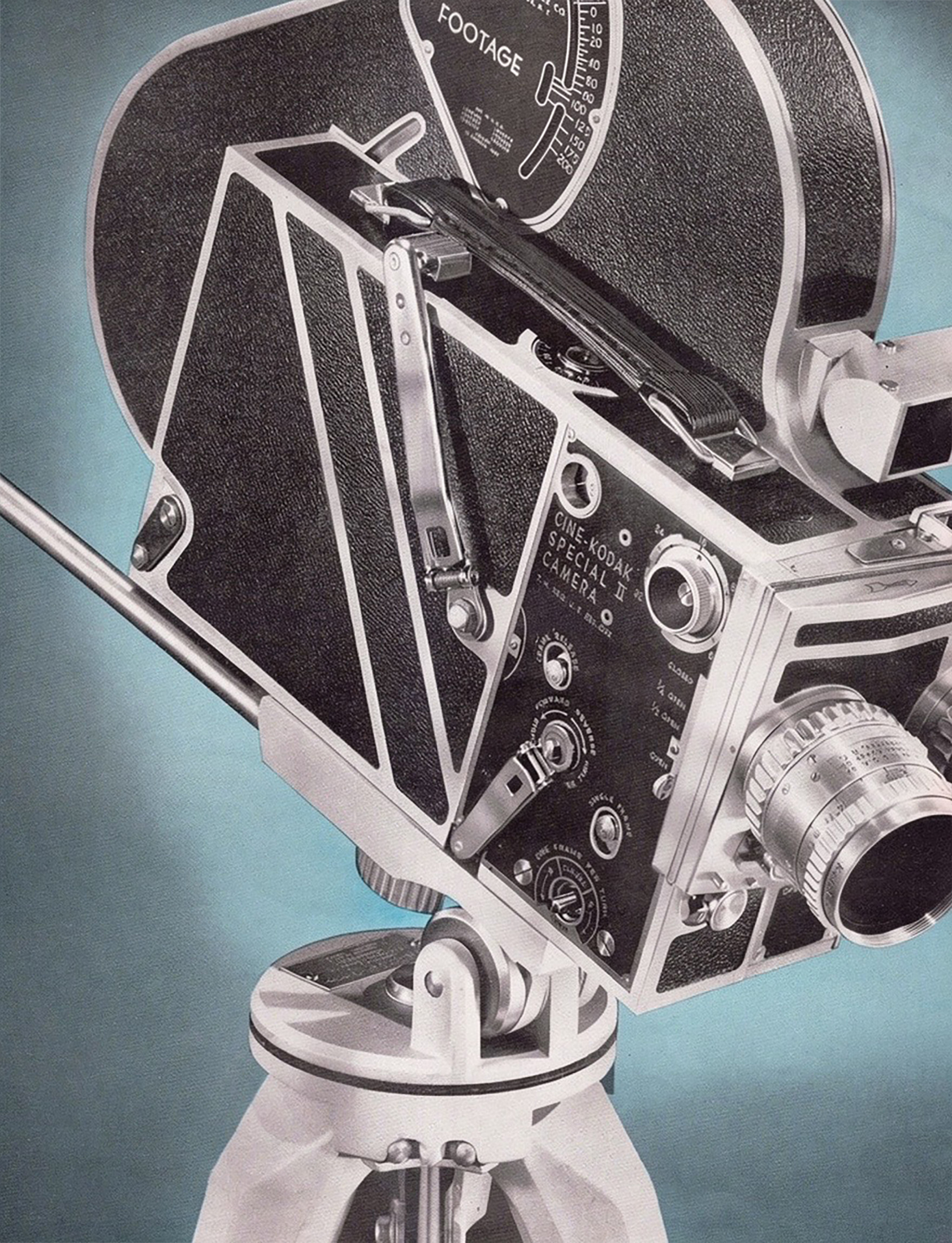

*Unsurpassed in 16mm. movie
versatility* **CINE-KODAK
SPECIAL II CAMERA**



FOOTAGE

CINE-KODAK
SPECIAL II
CAMERA

CLUB REWIND
FORWARD REVERSE
STOP

SINGLE FRAME
ONE FRAME PER SECOND

24
18
12
8
6
4
3
2

1/4 OPEN
1/2 OPEN
OPEN

Why the Cine-Kodak Special II Camera?

BECAUSE THERE IS A NEED in an increasing number of fields for a 16mm. motion picture camera that is compact, convenient to operate, easy to carry . . . that is outstandingly dependable . . . and at the same time *a camera that offers every special feature that could be considered desirable and important . . . that has the versatility and range to cope with unusual and exacting filming conditions . . . that is capable in itself of producing truly professional results.*

Such is the Cine-Kodak Special II Camera—today more than ever the choice of industrial photographers, engineers, doctors, scientists, lecturers, explorers, athletic instructors, newsreel and television cameramen. The original 16mm. professional-type camera—and still unsurpassed in versatility—the “Special II” is now available with a redesigned turret and other improvements. Here, without question, is a superb instrument for the making of outstanding 16mm. motion pictures.

The “Special II” looks and means business—whether used for filming in the factory, the studio, the laboratory, the operating room . . . on an athletic field, a busy city street, a lonely desert plateau. This illustration shows the camera fitted with Kodak Cine Ektar 102mm. and 25mm. Lenses, and with a 200-foot Film Chamber.

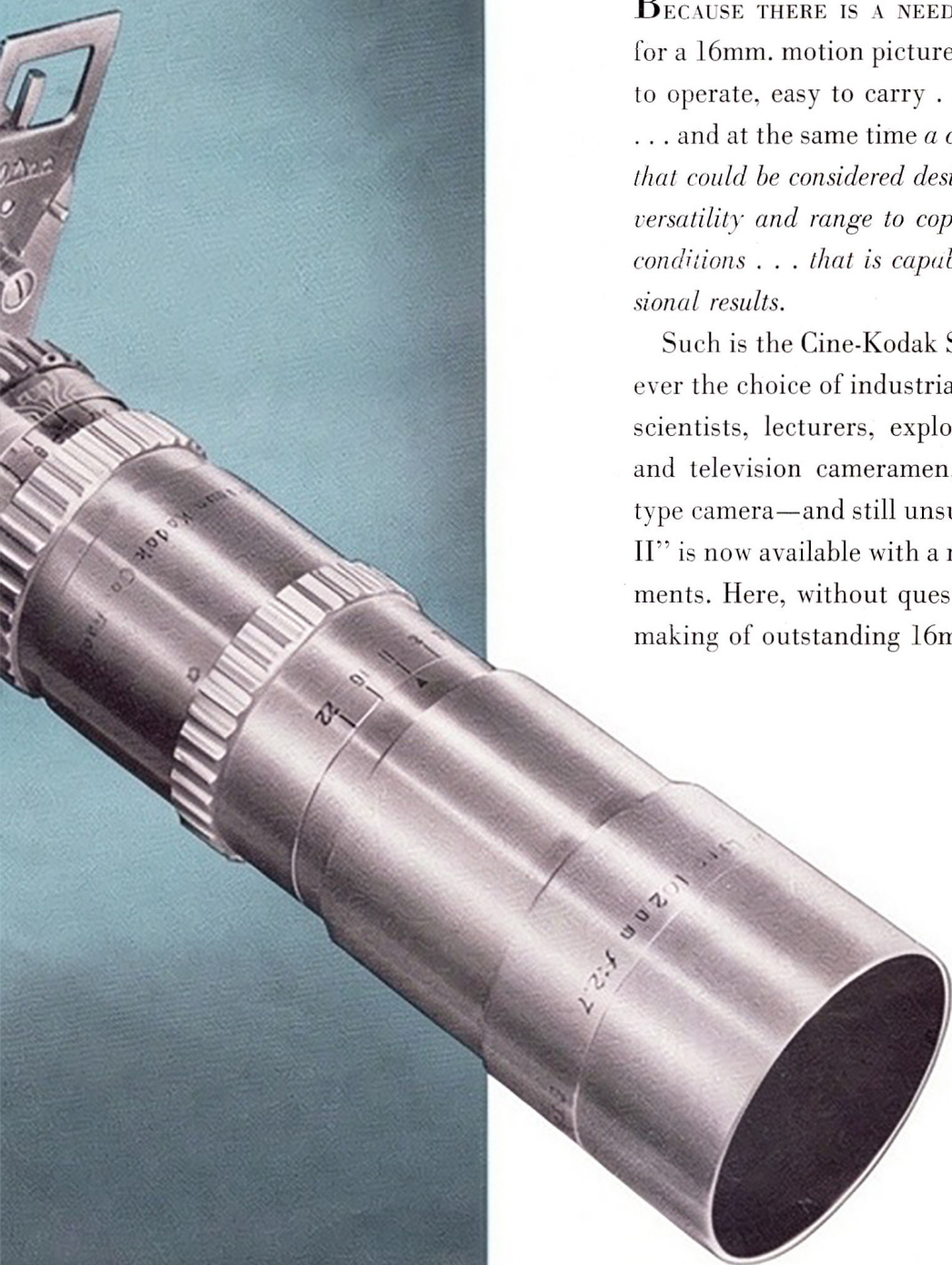

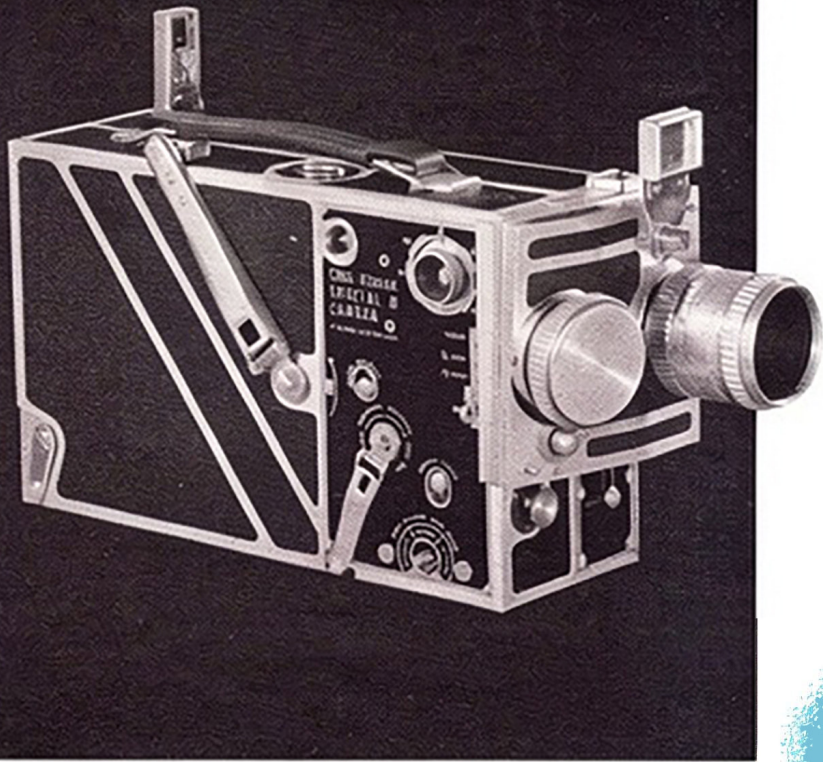

Product of precision manufacture and skilled hand craftsmanship, Cine-Kodak Special II Camera is justly famous for its "built-in" versatility—for what it can do without help of attachments of any kind. Fades, dissolves, mask shots, double and multiple exposures, montages, animations—all are readily achieved with the basic camera fitted with either a 100- or 200-foot interchangeable Film Chamber and with either an $f/1.4$ or $f/1.9$ Kodak Cine Ektar 25mm. Lens.

THE BASIC CAMERA

... with superb Kodak Cine Ektar Lens ... for finest picture quality

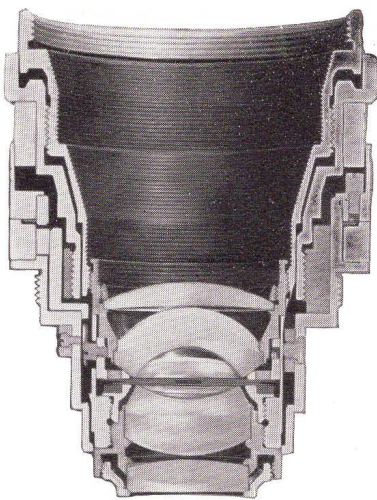

Cross section . . . Kodak Cine Ektar 25mm. $f/1.4$ Lens.

Whether the standard lens selected is the $f/1.4$ or the $f/1.9$, it will prove to be an important factor in assuring consistently splendid results with the "Special II." For these lenses well deserve their designation—*Ektar*—reserved for Kodak's finest lenses.

Both are products of Kodak's vast Hawk-Eye Optical Works—source not only of fine lenses for cameras and projectors, but optical systems for use in such diverse fields as photoradiography, television, and scientific research. It is at Hawk-Eye, too, that are developed such notable contributions to optical science as Kodak's famed rare-element glass—optical material whose unique properties are in large part responsible for the superb performance obtainable with Kodak Cine Ektar Lenses and other precision optical systems.

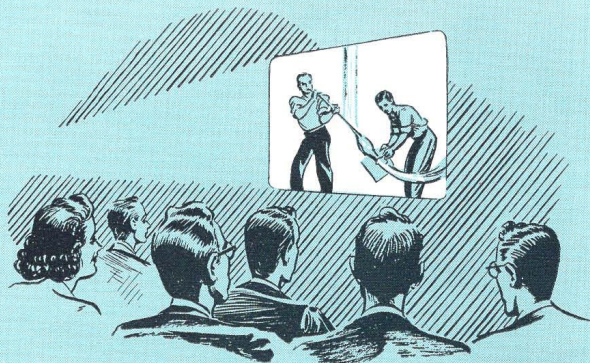

Cine-Kodak Special II Camera helps make principles and procedures crystal clear in films that teach new employees job fundamentals.

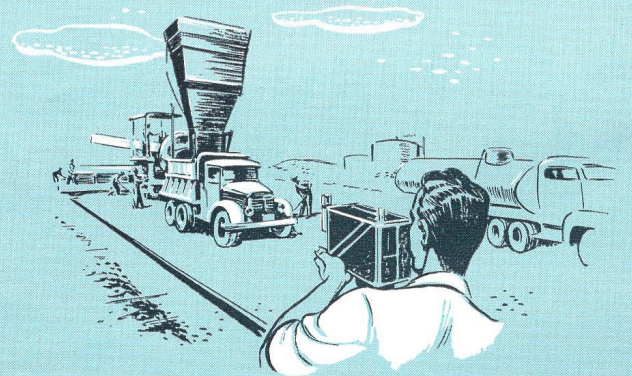

A highly satisfactory solution to the problem of demonstrating heavy equipment—motion pictures, such as can be made with the "Special II," showing the product in actual service.

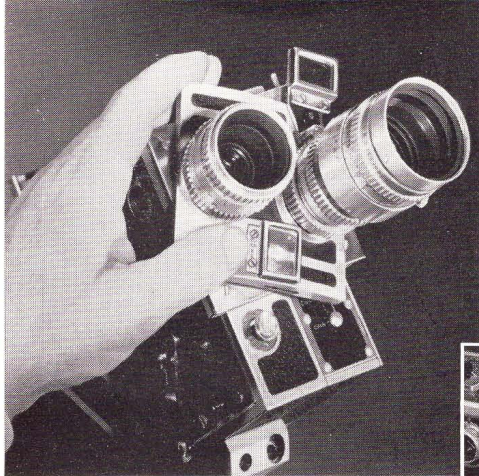

Rotating the turret brings "stand-by" lens into position. Only a simple turn is required.

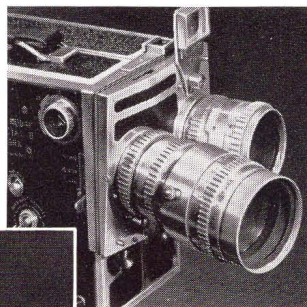

Above: The camera with the standard lens in place for filming.

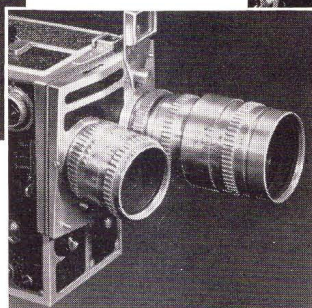

Left: Ready to shoot with the auxiliary lens. Swinging from one lens to another is accomplished in a second.

IMPROVED TWO-LENS TURRET

Accepts any combination of Kodak Cine Lenses

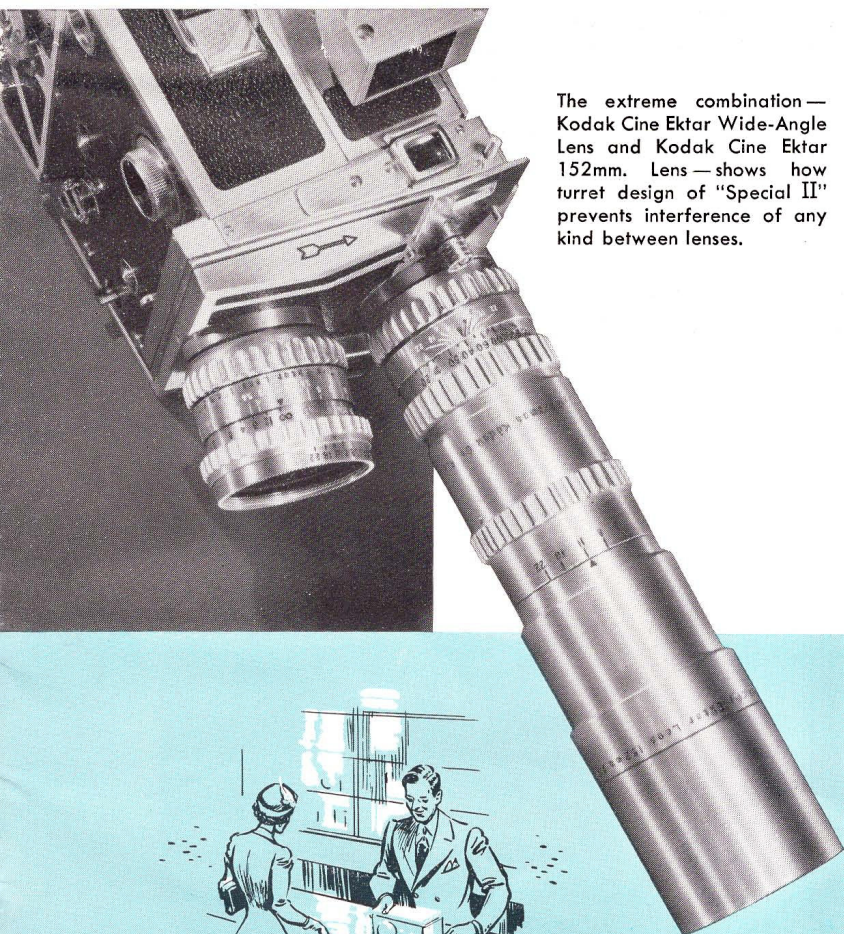

The extreme combination—Kodak Cine Ektar Wide-Angle Lens and Kodak Cine Ektar 152mm. Lens—shows how turret design of "Special II" prevents interference of any kind between lenses.

Making possible a quick swing from one lens to another with but the briefest interruption in filming, this turret is uniquely designed to take any two Kodak Cine Lenses at the same time, without physical or optical interference. All Kodak Cine Lenses—wide-angle, standard, or long-focus—can be attached directly to the camera. The lens mounts on the turret have slots that permit four-way positioning of the lenses, so that the index marks for the focusing and lens-opening scales can be read from the position made most convenient by the camera setup.



The "Special II" accepts all assignments—sales-training films, for example, which can be sent to dealers to help them increase the effectiveness of their over-the-counter selling.

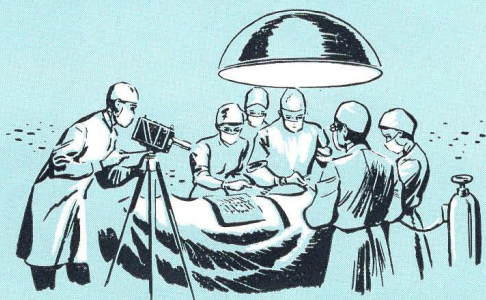

Filming surgical operations . . . a growing practice in the fields of medicine and dentistry, for which Cine-Kodak Special II Camera is splendidly suited.

EXCLUSIVE DUAL FINDER SYSTEM



The delights of travel—by air, land, or sea—can be persuasively depicted with motion pictures. The "Special II" is a favorite among makers of such promotional films.

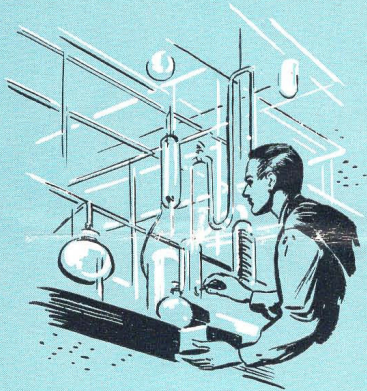

Another important industrial application of this camera is the recording of laboratory tests for subsequent study in the development and improvement of products.

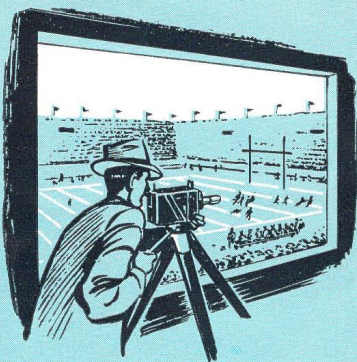

The athletic coach finds the "Special II" his number-one assistant in spotting flaws in team play . . . in mapping offensive and defensive strategy.

1. THE REFLEX FINDER . . . for exact framing and focusing through the lens

Here is an invaluable feature of the "Special II"—a reflex finder that permits you to sight through the lens in taking position . . . see the exact field covered at all distances . . . visually establish sharpness of focus . . . and eliminate the parallax problem. Of great value for all exacting work, this reflex finder is indispensable for extreme close-ups and special-effects photography. When masks are used, vertical and horizontal lines etched on the ground glass aid in determining the areas to be covered.

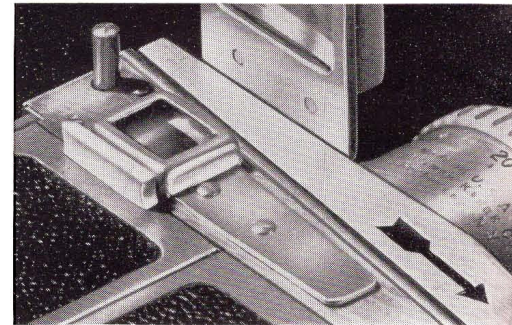

Plunger sets mirror of reflex finder for ready viewing. Mirror drops automatically when exposure button is pressed.

2. THE EYE-LEVEL FINDER . . . for following action

This direct view finder enables the cameraman to sight at convenient eye level . . . keep up with fast-moving action. At the same time, it permits him to see what is going on outside the field covered by the lens . . . to be ready for unexpected action that might occur. A complete series of front finders makes it possible to match the field of view with that of any Kodak Cine Lens. Of a new handy clip-on type, these finders are quickly attached and removed. The permanently attached rear peep-sight—usable both with standard front finders and with Cine-Kodak Sports Finders—has an ingenious built-in slide, which, when adjusted, corrects for parallax as close as two feet.

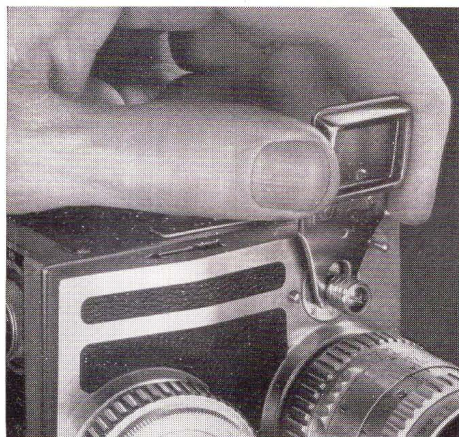

Clipping on front finder—there's one for every lens.

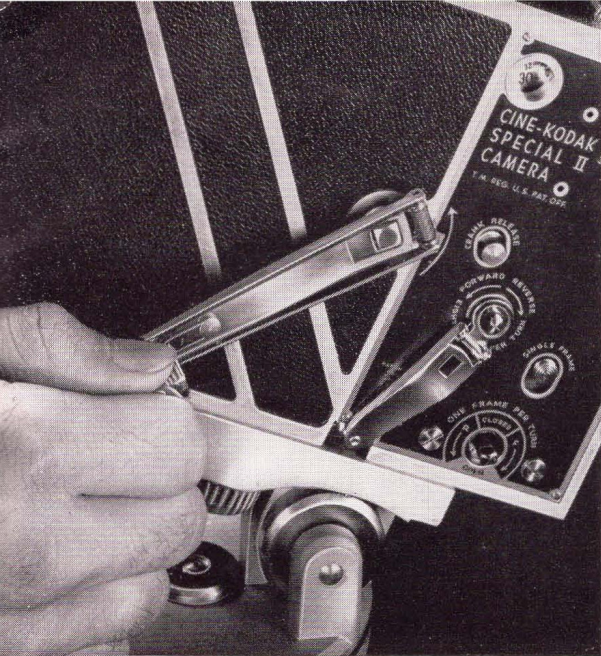

One spring-motor winding—to expose 38 feet of film.

The spring-motor drive of the Cine-Kodak Special II Camera will, when fully wound, expose about 38 feet of film—a continuous shot of more than a minute and a half when operated at normal silent speed. Should it be necessary to continue filming for an additional period, the camera can readily be hand cranked. (See next page.)

THE SPRING-MOTOR DRIVE

... long-running, smooth, dependable

This long-running spring motor permits the filming of close to a dozen average-length scenes without rewinding . . . as well as the uninterrupted filming of one subject requiring extra-long footage. More than that, the precision of the mechanism—plus fully effective governor control—assures extremely smooth, even operation at any desired indicated speed from 8 to 64 frames per second. In high-speed operation, a cushioned braking action protects the mechanism, reducing jars and vibration to a minimum when the motor is stopped.

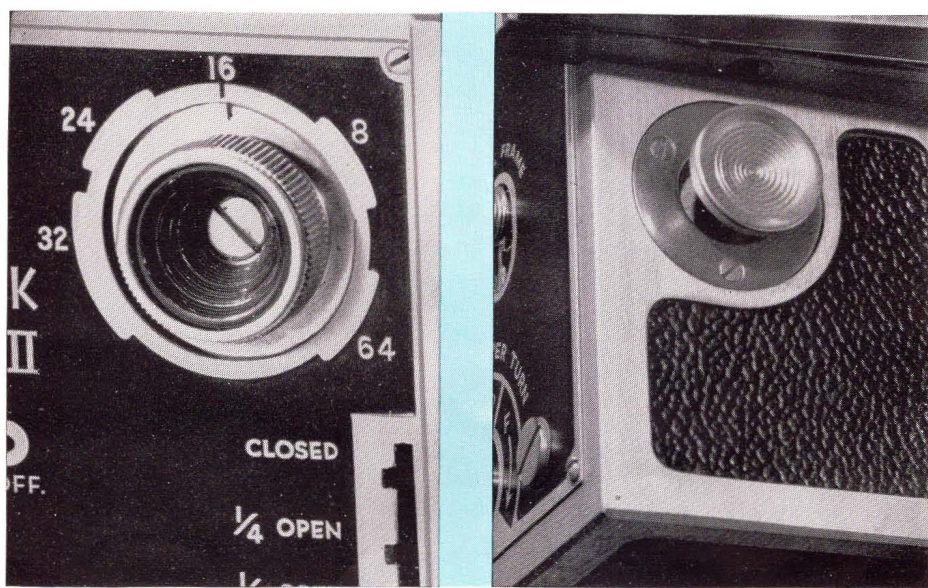

Speed, 8 to 64 frames per second, is selected by means of this dial.

Exposure button is conveniently located . . . can be locked in running position.

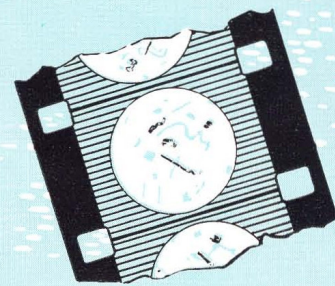

Motion pictures made through the eye of the microscope . . . an important contribution of the Cine-Kodak Special II Camera to medical and scientific research.

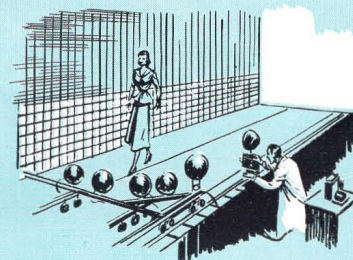

Gait studies, providing useful data to orthopedists and shoe manufacturers, reveal the "Special II" playing a major role in the investigation.

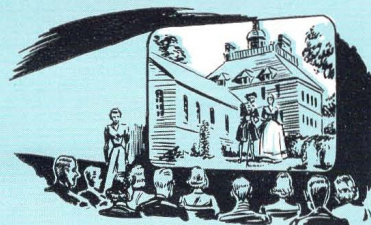

In the field of education, motion pictures are recognized today as a basic type of instruction. Filmed with the "Special II," such movies have attained true quality and distinction.

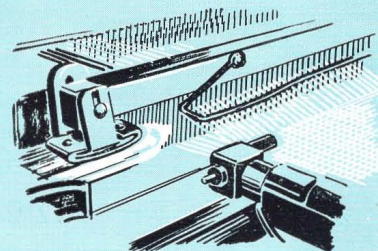

How your company's products are made—a story that can sell, instruct, entertain . . . one that the "Special II" can help tell in superlative fashion.

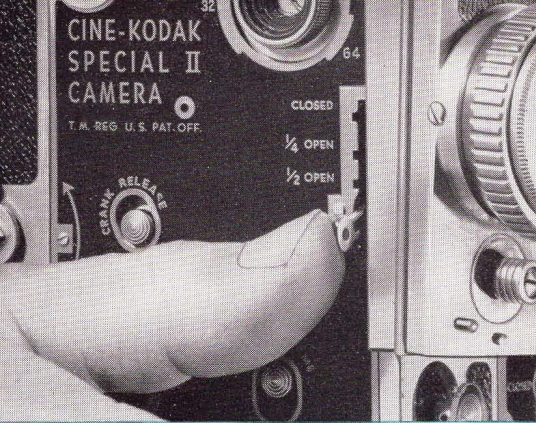

Adjustable-opening shutter

A key versatility feature of the "Special II," this shutter permits the making of fades and dissolves . . . more flexible exposure control . . . reversing or advancing film without exposing it . . . obtaining sharper images of moving objects. By means of a lever on the side of the camera, the shutter can be gradually opened or closed while the camera is running—or it can be set at "open," "half-open," "one-quarter open," or "closed" position.

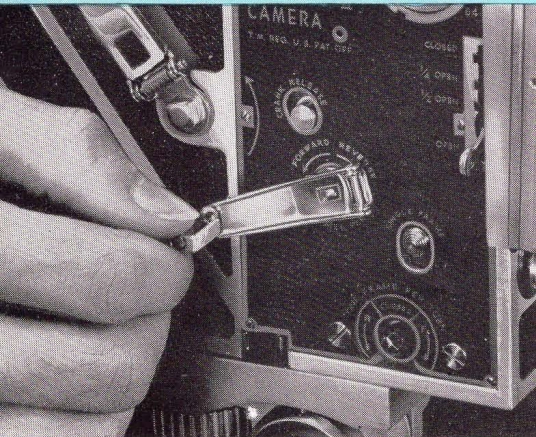

One- and eight-frame shafts

Attaching the interchangeable handle to either of these shafts readies the "Special II" for hand cranking whenever desirable or necessary. The eight-frame shaft enables the cameraman to wind film forward or backward in making lap dissolves and double or multiple exposures—or to complete the filming of an exceptionally long scene should the motor run down before its conclusion. The one-frame shaft is useful in making single-frame exposures for animation effects, or when very poor light conditions necessitate long exposures.

Controls for Special Effects and Added

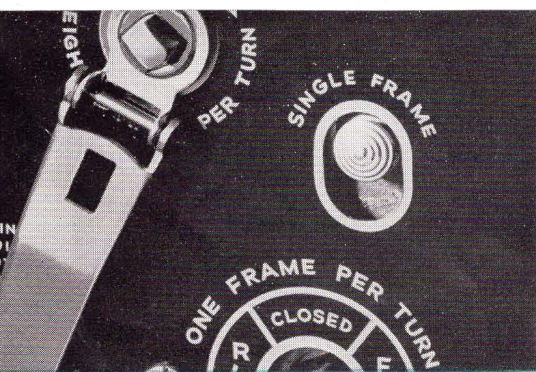

Single-frame release

Filling much the same purpose as the one-frame shaft, but geared to the spring-motor drive, this release exposes exactly one frame of film. Because it gives each frame uniform exposure, it is a convenient device for the production of animation effects and for speeding up very slow action.

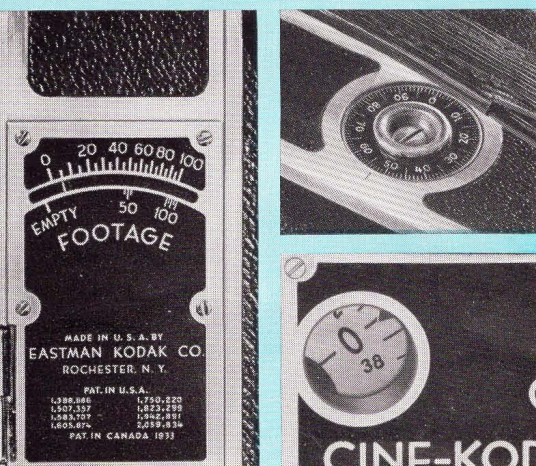

Footage meters and frame counter

These tell at a glance the complete, accurate story of the camera's film supply. The meter on each Film Chamber (far left) indicates the unexposed film remaining on the roll. The footage meter (left) and frame counter (left, below) on the camera register the exposed film and operate in both directions—a feature essential to accurate gauging of multiple exposures and dissolves.

The control panel of the "Special II" shows the convenient grouping of the many positive, simplified controls that give this unusual camera such exceptional versatility.

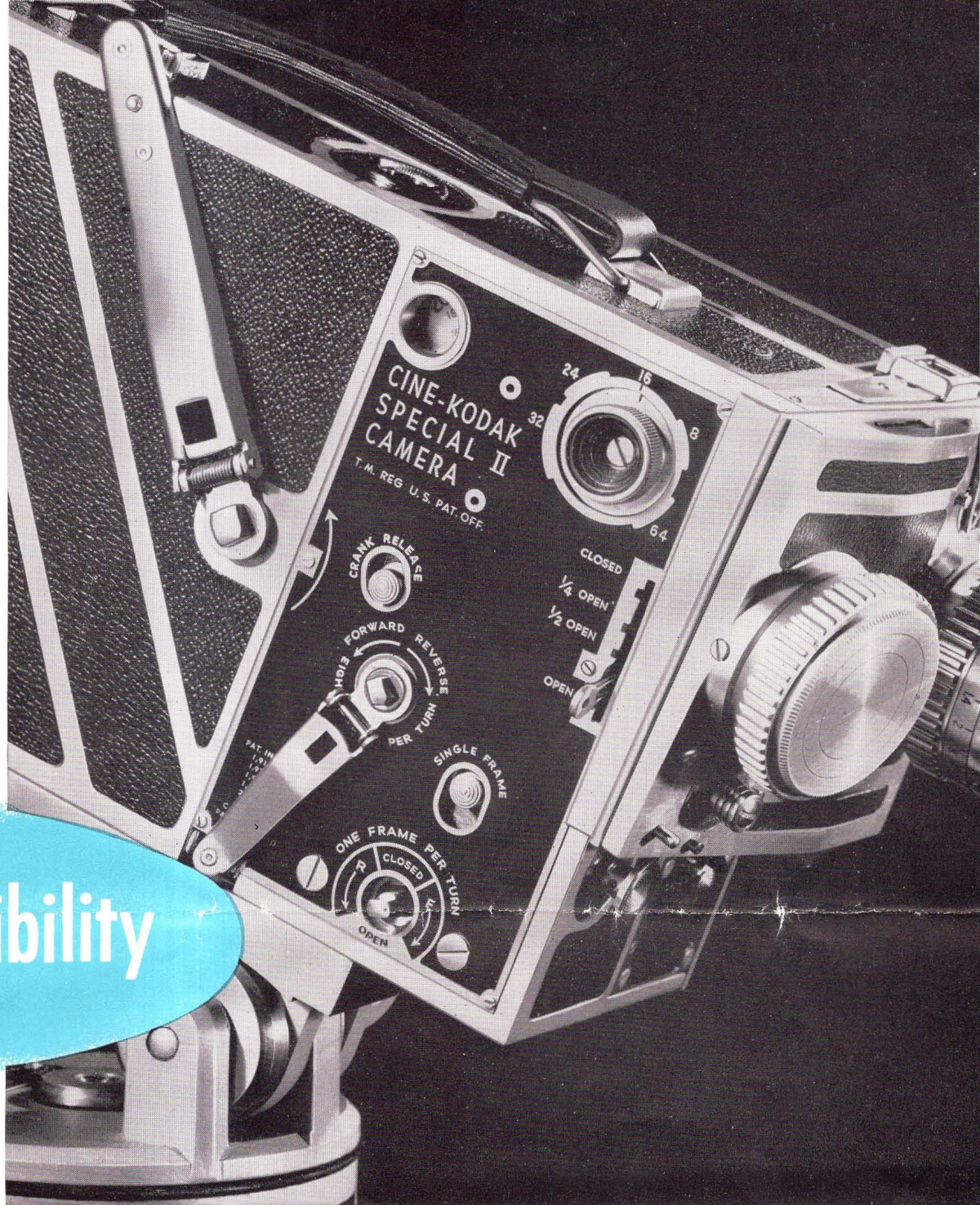

Filming Flexibility

Masks

No need for a bulky mask box! With the "Special II," masks are simply slipped into a slot between lens and film. Generally used in conjunction with the special controls on the camera, the set of six masks provides an easy way of achieving a variety of special effects—different types of multiple exposures and montages, as well as simple oval or circular framing of the screened images.

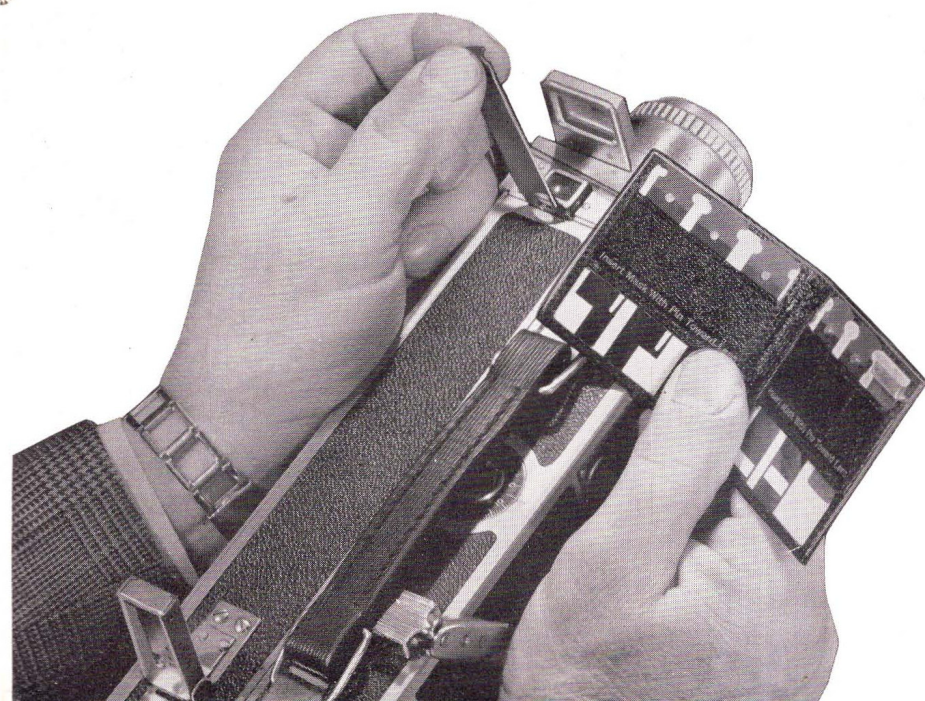

A COMPLETE SYSTEM OF OPERATING SAFEGUARDS

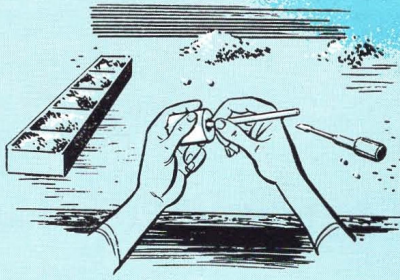

"Always a better way." This camera can point the path, revealing through slow-motion sequences, unnecessary, fatiguing, and time-wasting motions too fast for the human eye.

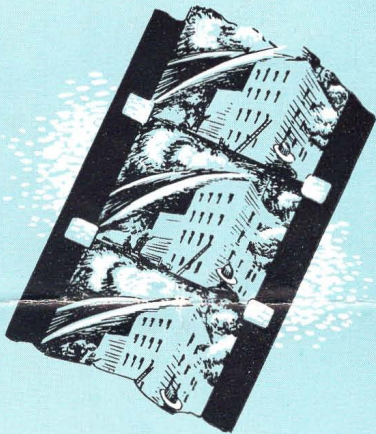

With television established in all major cities, spot news is video news. It's not surprising that television stations are finding Cine-Kodak Special II Camera an ace reporter of events.

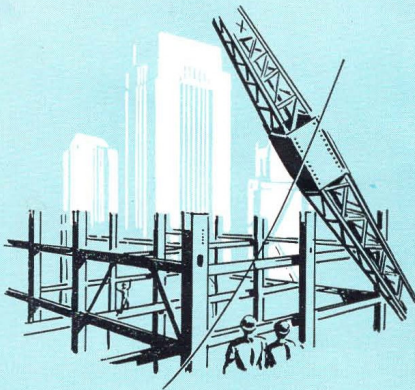

The motion picture records of big construction projects take on added interest and reference value when filmed with the "Special II."

Despite the number and variety of special features and refinements built into the Cine-Kodak Special II Camera, operation of the camera is very nearly "foolproof." Several ingenious devices, plus equally ingenious methods of interlocking parts of its mechanism, combine to protect against unfamiliarity or oversight.

1. A bell sounds shortly before the motor is fully wound, warning the cameraman to slow down for the last few turns. As hand cranking in reverse also winds the motor, the bell serves as a warning signal in this operation, too.
2. The same bell sounds several seconds before the motor runs down completely so that the operator has time to end the scene, or to get set for hand cranking.
3. The governor helps maintain even speed in hand cranking, counteracting any tendency of the cameraman to turn the crank faster than the required speed.
4. A cushioned braking action comes into play in high-speed operation (64 frames per second), bringing the motor to a smooth halt and preventing injurious jars and vibration.
5. The reflex finder closes automatically when the exposure button is pressed.
6. When the adjustable shutter lever is moved to its "closed" position at the end of a fade, the motor stops automatically.
7. With the adjustable shutter closed, the spring motor can be started again or the mechanism cranked to start a fade-in, "back up" for a double exposure, etc. At such times a buzzer sounds as a reminder that the shutter is yet to be opened.
8. When the aperture cover button below the lens is in "open" position, the Film Chamber cannot be removed from the mechanism half of the camera, thus avoiding even a frame of light-struck film. And if the Chamber has been removed, it cannot be replaced until this button is in "closed" position.
9. When the aperture button is in "closed" position, the exposure button of the camera will not start the motor—no chance of running film without exposure.
10. Film Chamber covers cannot be shut until the sprocket clamp is closed and film spools are properly seated on spindles.

Adjustable shutter closed . . . warning buzzer sounds.

Aperture cover button on "open" . . . Film Chamber cannot be removed.

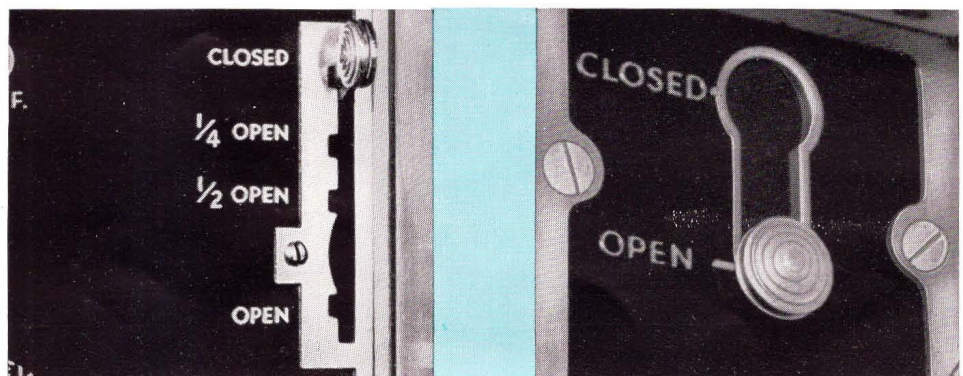

Seven superb Kodak Cine Ektar Lenses—the finest lenses ever made for 16mm. motion picture cameras—are available for use with the “Special II.” Illustrated here, they are: top row from left, the 15mm. $f/2.5$ wide-angle lens, the 25mm. $f/1.4$ standard lens, and the 25mm. $f/1.9$ standard lens; right center, the 40mm. $f/1.6$ lens; lower row, the 152mm. $f/4.0$ lens, the 102mm. $f/2.7$ lens, the 63mm. $f/2.0$ lens.



A WIDE CHOICE OF LENSES

for extended filming range

Everything that has been said on an earlier page about the standard Kodak Cine Ektar 25mm. $f/1.4$ and $f/1.9$ Lenses applies to the full line of Kodak Cine Ektar Lenses. In every way, these superb lenses merit the name, *Ektar*—Kodak’s highest quality designation. For though the lenses are designed to provide exceptional speed, performance is outstanding *even at widest apertures.*

Kodak lens design makes it possible. Every internal detail contributes to the reduction of flare . . . to the transmission of a maximum of image-forming light. Lens rims are blackened, glass-air surfaces are Lumenized, mounts are corrugated, flanges are beveled. External features keep pace . . . make for convenience and accuracy in adjustments. Aperture scales are widely and evenly spaced. Integral depth-of-field scales show the range of good focus at all openings. And evenly graduated distance scales permit remarkably accurate focusing.

These Ektar Lenses give the user of the Cine-Kodak Special II Camera a splendid opportunity for a selection well suited to his particular filming requirements. The longer focal-length lenses not only will span distances to give apparent close-ups of faraway objects, but also can greatly magnify small objects close by . . . give concentrated field coverage . . . improve perspective . . . eliminate undesired backgrounds. The wide-angle lens, by covering a wider-than-normal field, solves the problem of filming in cramped quarters where backing-up space is limited. Any combination of two can be quickly attached to the turret of the “Special II.”



Intimate, revealing glimpses of wild birds and animals in their native habitats . . . prize nature-study shots are easily captured with this superb camera and its auxiliary equipment.

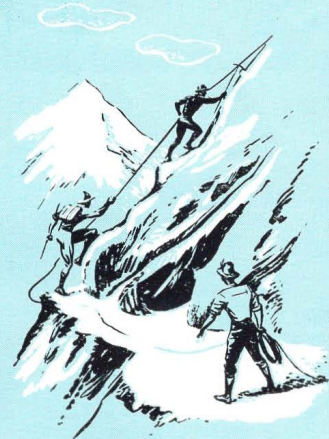

Thrills, mystery, danger, enchantment—the maker of travelogues searches for them all over the globe. To him, the Cine-Kodak Special II Camera has proved to be the one indispensable tool of his calling.

KODAK AUXILIARY EQUIPMENT

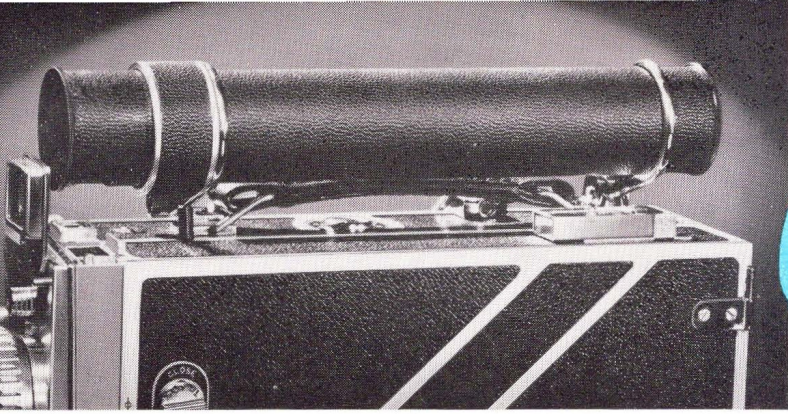

Reflex Finder Image Magnifier permits hair-line framing and focusing from a convenient position in back of the camera.

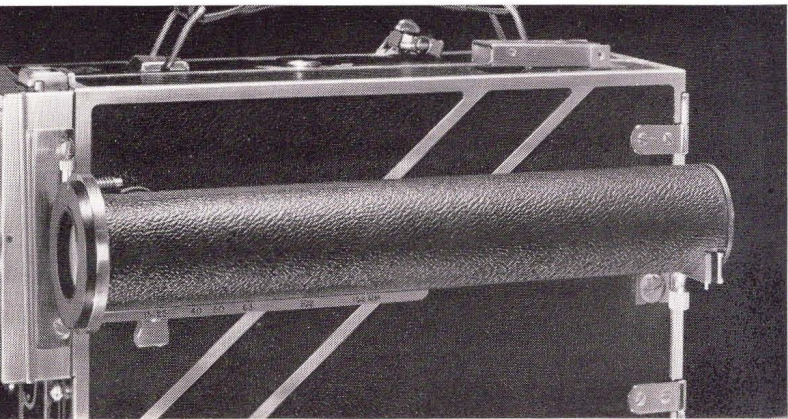

Optical Finder shows fields—completely corrected for parallax—of all Kodak Cine Lenses supplied for the "Special II."

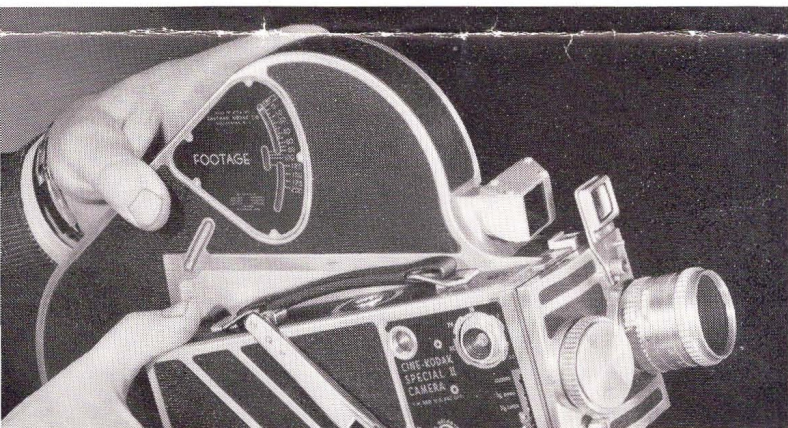

Interchangeable Film Chambers permit switching film types any time... make possible rapid reloading without rethreading.

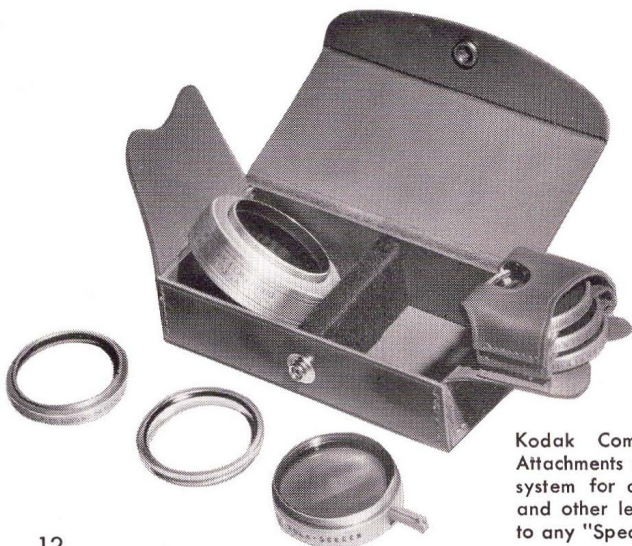

Kodak Combination Lens Attachments are a versatile system for attaching filters and other lens attachments to any "Special II" lens.

The range of the basic "Special II" Camera is so broad that relatively little auxiliary equipment is ordinarily required. The items on these pages, however, are so generally useful . . . and assist in so many movie situations . . . that they are frequently utilized to further widen the scope of the camera.

Reflex Finder Image Magnifier

As its name implies, this device magnifies the reflex finder image while making it possible to view the image from the back of the camera. Images are seen as they appear to the eye—right side up. Here, indeed, is especially valuable equipment for any filming that requires precise framing and focusing. (The Reflex Finder Image Magnifier is usable only with cameras equipped with 100-foot Film Chambers and must be fitted at the factory.)

Optical Finder

Correcting for parallax down to two feet, the Optical Finder for the Cine-Kodak Special II Camera has a graduated magnifying lens which can be set to indicate the field covered by any Kodak Cine Lens. It is particularly useful when lenses of different focal lengths are often interchanged. (The Optical Finder must be fitted at the factory.)

Interchangeable Film Chambers

The "Special II" is a camera of two distinct halves—one part containing the spring motor, operating mechanism, and major operating controls; while the other is a film chamber containing pulldown mechanism, gate, and reel spindles. Whether you select a basic camera with a 100- or 200-foot film chamber, you can also obtain additional chambers of either capacity and use them interchangeably with the original film chamber. As a result, the camera can be reloaded in a matter of seconds without the immediate necessity for

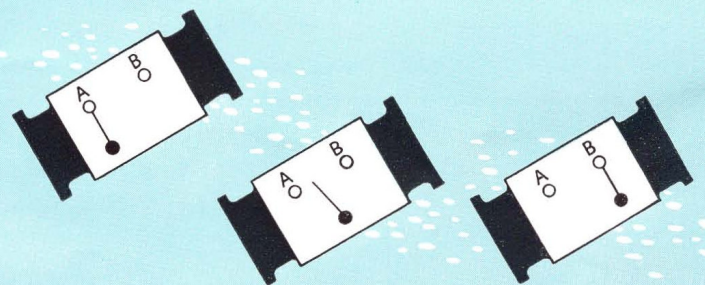

Animated symbols, graphs, drawings, etc., are often helpful—even essential—elements of technical and scientific motion pictures. Making them is all in the day's work for the "Special II."

rethreading . . . and film types can be switched safely at any time, even when part of a roll remains unexposed.

Kodak Combination Lens Attachments

This simple but highly versatile system of lens attachments makes possible acquiring inexpensively . . . and using conveniently . . . a full complement of attachments for the camera's standard and auxiliary lenses. Among the attachments are filters for color and black-and-white filming, Pola-Screens, Portra (supplementary) Lenses, and lens hoods.

Kodak Ektar *f*/1.4 Converter, 25mm. to 15mm.

The Ektar Converter screws into the Kodak Cine Ektar 25mm. *f*/1.4 Lens to expand its field of coverage by 60% without loss in speed or quality. This provides, in effect, an additional *f*/1.4 Ektar Lens—of 15mm. focal length—at a fraction of the cost of so fast, so optically excellent, an item of optical equipment. (The Converter can be used only with the 25mm. *f*/1.4 Ektar Lens.)

Cine-Kodak Lens Spacer Rings

These simple yet effective movie aids provide the means for extending the camera's close-up range to permit filming minute movie subjects. Designed to be used with standard and auxiliary lenses, they make possible coverage of fields as small as 1/2 inch in width.

Carrying Cases

Cases to accommodate the Cine-Kodak Special II Camera and a full complement of auxiliary equipment are available in two sizes—for cameras equipped either with 100- or 200-foot film chambers. Both cases are compartmented to accept camera, extra film chamber, Reflex Finder Image Magnifier, Optical Finder, auxiliary lenses, lens attachments, and a supply of film.

Cine-Kodak Sports Finders (not illustrated)

These open-frame finders provide an image of normal size instead of the reduced image seen through the negative lenses of the finders normally supplied . . . hence, facilitate anticipating and following action. Sports Finders necessitate the use of a special Rear Sports Finder Assembly, simple to install and usable with both regular and sports finders.

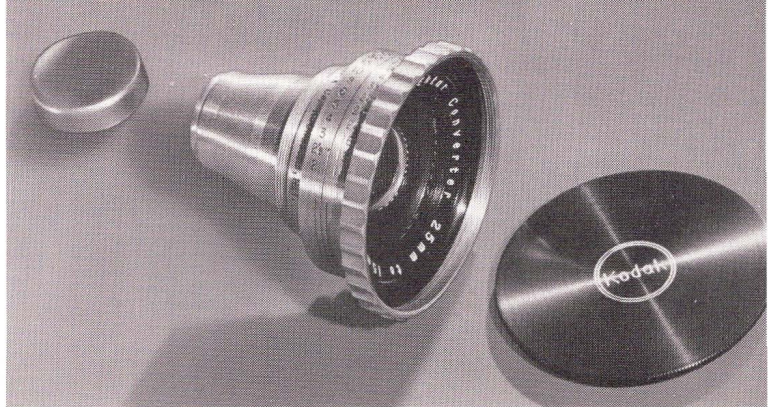

Kodak Ektar Converter shortens the effective focal length of the 25mm. *f*/1.4 Ektar standard lens to 15mm.

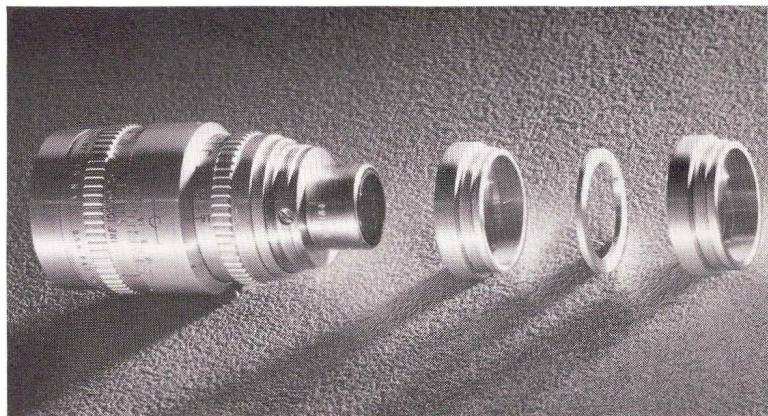

Cine-Kodak Lens Spacer Rings bring tiny movie subjects into range . . . make possible near-microscopic close-ups.

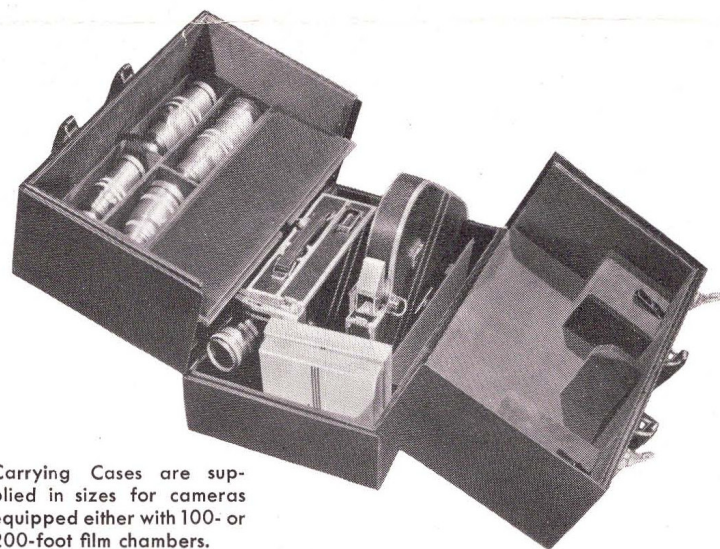

Carrying Cases are supplied in sizes for cameras equipped either with 100- or 200-foot film chambers.

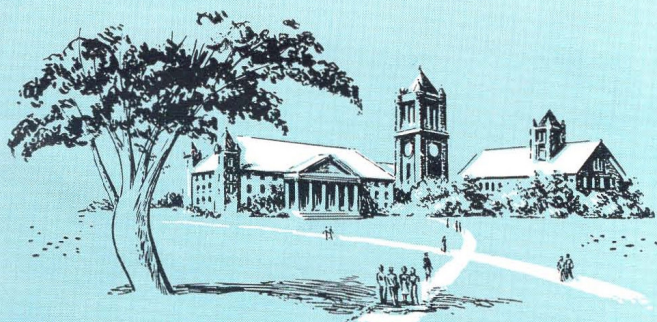

Motion pictures are a valuable publicity medium for universities and other institutions. For them, the excellence of such films made with the "Special II" is in itself an added mark of merit.



Many who find the "Special II" helpful in their business or profession will also find it a delightful after-hours companion for making family movies and other films of personal interest.

OTHER AUXILIARY EQUIPMENT

for the Cine-Kodak Special II Camera

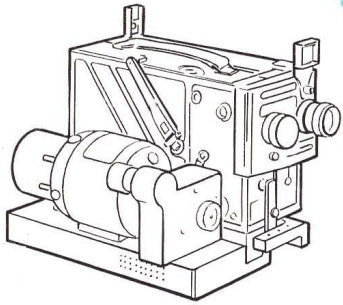

1.

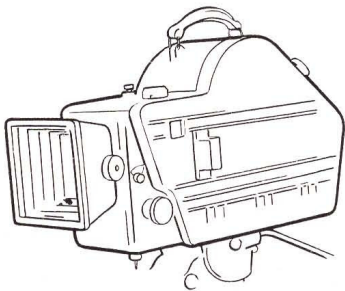

2.

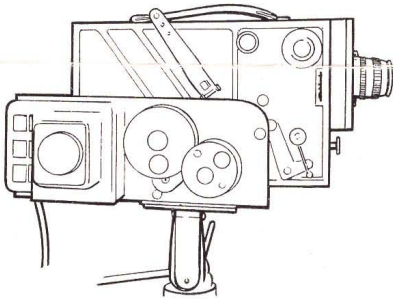

3.

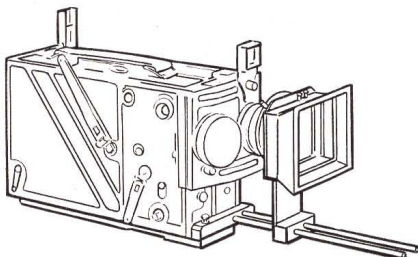

4.

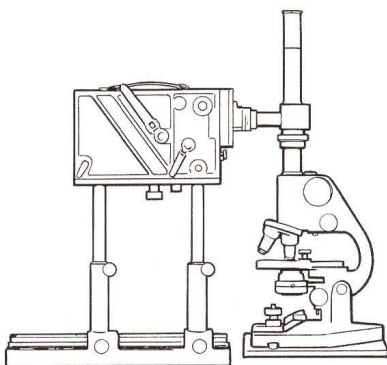

5.

In addition to the Kodak equipment described on the preceding pages, a number of other items for use with the Cine-Kodak Special II Camera are today on the market. Designed to solve special filming problems and to adapt the camera to specific types of advanced motion picture making, they will be of interest to many "Special II" users. Kodak will be glad to furnish the names and addresses of the various manufacturers on request.

1. Electric-Motor Drives

Connected to the one-frame shaft of the camera, an electric-motor drive eliminates the need for periodic rewinding of the spring mechanism and makes possible continuous exposure for the entire length of a roll of film.

2. Blimps

When sound is recorded synchronously with exposure, the need to reduce extraneous noise to a minimum is obvious. A blimp will likewise effectively damp the sound made by an electric motor drive on the camera.

3. Time-Lapse Outfits

Changes in the position and appearance of an object—so slow as to be imperceptible to the eye—can be shown speeded up hundreds of times in movies filmed with the "Special II" and an electric time-lapse outfit. Providing full automatic control of the camera, this equipment makes possible the production of single-frame exposures at intervals ranging from a few seconds to many minutes, proving of great value in growth studies and in related types of scientific, technical, and industrial research.

4. Matte Boxes

These satisfy the preference of some cameramen for a mask and filter holder extending out in front of the camera's lens. Such a box provides a convenient means of using special types of masks, filters, etc., in a wide range of combinations.

5. Equipment for Cine Photomicrography

Movies of microscopic phenomena are possible with a Cine-Kodak Special II Camera, a microscope, and specially designed auxiliary equipment. The sketch shows all the essentials including an observation eyepiece which enables the operator to study the subject during exposure, thus avoiding any waste of film.



CINE-KODAK FILMS FOR THE "SPECIAL II"

Single-perforated film for sound recording . . . as well as film in standard, double-perforated form

Because the camera is designed to run single-perforated films without adaptation, the "Special II" will not only accept standard double-perforated films, but 16mm. sound recording films as well. Hence, when magnetic sound recording and projection systems become generally available, "Special II" users can enter this field without a single modification of their basic equipment. The following reversal films—processed by Kodak without extra charge—are available either with single or double perforations:

Kodachrome Film, Daylight Type, makes possible magnificent full-color movies of startling realism under practically all daylight conditions. **Kodachrome Film, Type A**, color balanced for photoflood illumination, provides excellent full-color results indoors. **Cine-Kodak Super-X Panchromatic Film** is a fast, fine-grained black-and-white film, wonderfully suitable for all-round movie making indoors and out.

In addition to these films, a number of more or less special-purpose films are available. Most prominent among these is Cine-Kodak Super-XX Film, an extremely high-speed film for use under difficult lighting conditions. ("Super-XX" is supplied only in double-perforated form.) Also available are Cine-Kodak reversal films supplied for processing by the customer . . . and Cine-Kodak Negative Films—such as the ultra-fast new Cine-Kodak Tri-X Negative Film—which, unlike reversal films, are not projected but are used to make projection prints.

All Kodak 16mm. motion picture films are supplied in both 100- and 200-foot rolls.

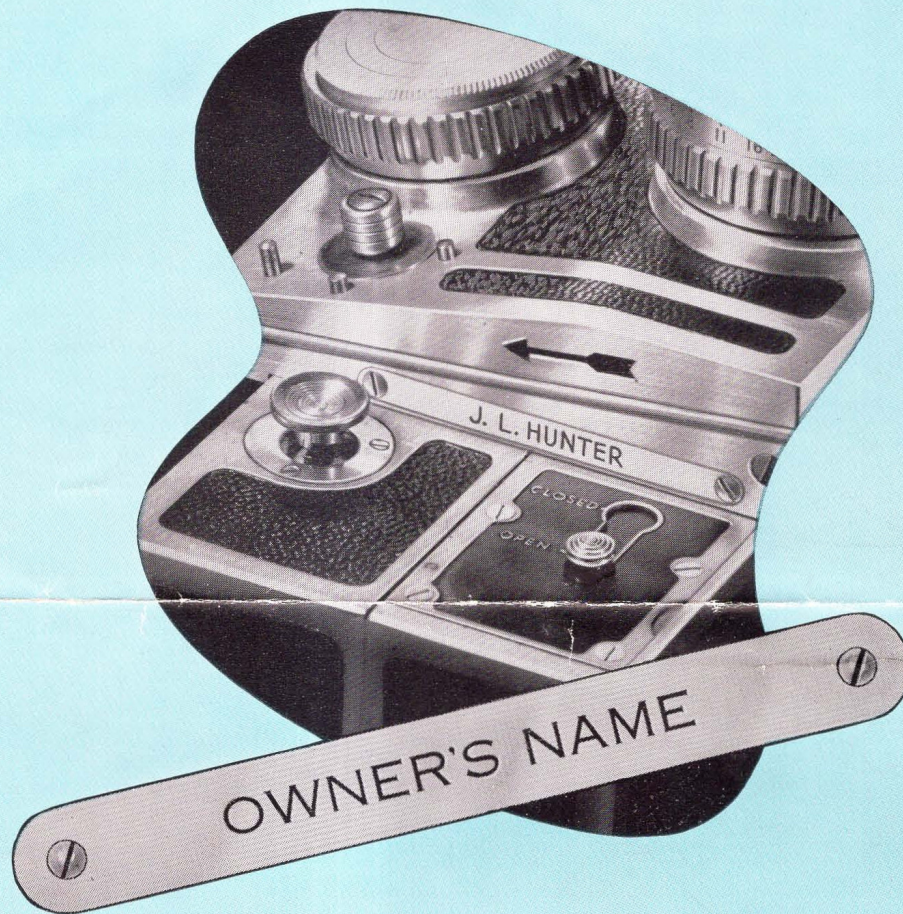

It is fitting that such a truly superb precision instrument as the Cine-Kodak Special II Camera should carry the name of its owner—whether individual, company, or institution. If requested at the time the camera is ordered from your Kodak dealer, this name plate is engraved at the factory without extra charge.

EASTMAN KODAK COMPANY · Rochester 4, N. Y.



CINE-KODAK SPECIAL II CAMERA

List Prices

Cine-Kodak Special II Camera

With Kodak Cine Ektar Lens, 25mm <i>f</i> /1.4, and 100-ft. Film Chamber.....	\$1,430.00
With Kodak Cine Ektar Lens, 25mm <i>f</i> /1.4, and 200-ft. Film Chamber.....	1,640.00
With Kodak Cine Ektar Lens, 25mm <i>f</i> /1.9, and 100-ft. Film Chamber.....	1,365.00
With Kodak Cine Ektar Lens, 25mm <i>f</i> /1.9, and 200-ft. Film Chamber.....	1,575.00

Principal Auxiliary Equipment

Additional 100-ft. Film Chamber.....	425.00
Additional 200-ft. Film Chamber.....	635.00
Reflex Finder Image Magnifier (fitted to camera).....	160.00
Optical Finder (fitted to camera).....	187.00
Adapting extra chambers to use Optical Finder.....	37.50
Kodak Compartment Case for Cine-Kodak Special Cameras, 100-ft. model.....	49.50
200-ft. model.....	80.00

Kodak Cine Ektar Lenses (in S Mount)

Kodak Cine Ektar Lens, 15mm <i>f</i> /2.5.....	\$ 105.00
Kodak Cine Ektar Lens, 25mm <i>f</i> /1.9.....	133.00
Kodak Cine Ektar Lens, 25mm <i>f</i> /1.4.....	198.00
Kodak Cine Ektar Lens, 50mm <i>f</i> /1.9.....	129.00
Kodak Cine Ektar Lens, 63mm <i>f</i> /2.0.....	139.00
Kodak Cine Ektar Lens, 102mm <i>f</i> /2.7.....	145.00
Kodak Cine Ektar Lens, 152mm <i>f</i> /4.0.....	160.00

(All Kodak Cine Lenses are *Lumenized*—hard-coated for lens protection and to improve picture detail and color purity.)

Kodak Ektar <i>f</i> /1.4 Converter, 25mm to 15mm....	76.50
-------------------------------------------------------	-------

Finders for Cine-Kodak Special II Camera

15mm, 25mm, 40mm, 50mm, 63mm (each)....	10.00
-----------------------------------------	-------

Cine-Kodak Sports Finders

25mm, 50mm, 63mm (each).....	14.50
102mm, 152mm (each).....	6.75

Cine-Kodak Lens Spacer Rings (per set).....	10.50
---------------------------------------------	-------

KODAK 16mm MOTION-PICTURE FILMS

The information below supersedes that given on page 15 of the booklet *Cine Kodak Special II Camera*.

16mm SAFETY FILMS, perforated two edges

Kodak Reversal Films

Kodachrome Movie Film, Daylight Type,	100-ft. rolls	\$ 8.00
	200-ft. rolls	13.35
Kodachrome Movie Film, Type A,	100-ft. rolls	8.00
	200-ft. rolls	13.35
Plus-X Reversal Movie Film,	100-ft. rolls	5.40
	200-ft. rolls	9.15
Tri-X Reversal Movie Film,	100-ft. rolls	5.40
	200-ft. rolls	9.15

Kodak Negative Films

Plus-X Negative Movie Film,	100-ft. rolls	4.60
	200-ft. rolls	7.75
Tri-X Negative Movie Film,	100-ft. rolls	4.60
	200-ft. rolls	7.75

16mm SAFETY FILMS, perforated one edge

Kodak Reversal Films

Kodachrome Movie Film, Daylight Type,	100-ft. rolls	\$ 8.00
	200-ft. rolls	13.35
Kodachrome Movie Film, Type A,	100-ft. rolls	8.00
	200-ft. rolls	13.35
Plus-X Reversal Movie Film,	100-ft. rolls	5.40
	200-ft. rolls	9.15
Tri-X Reversal Movie Film,	100-ft. rolls	5.40
	200-ft. rolls	9.15

Kodak Negative Films

Plus-X Negative Movie Film,	100-ft. rolls	4.60
	200-ft. rolls	7.75
Tri-X Negative Movie Film,	100-ft. rolls	4.60
	200-ft. rolls	7.75

(Prices do not include processing. Kodak processing services for Kodachrome Film are available through Kodak dealers. Processing services for Plus-X and Tri-X reversal and negative movie films are available from independent processing laboratories.)

Prices are list, include Federal Tax where applicable, and are subject to change without notice.

EASTMAN KODAK COMPANY • ROCHESTER 4, N. Y.