

# Canon AF35ML



INSTRUCTIONS

Thank you for selecting the Canon AF35ML. This compact camera offers autofocus, auto exposure, auto film loading, auto film advance and power rewind. These innovative features, along with a built-in auto flash, make the AF35ML not only easy to use, but fun to use as well.

With a few minutes invested in reading these instructions, the AF35ML's operation will become as automatic as its many features. We at Canon hope your new AF35ML will open up a world of pleasurable picture-taking experiences.

Unfold the front and back flaps of this booklet for reference to camera parts while you read. Circled numbers after part names in the text correspond to numbers on pp. 3 & 26.

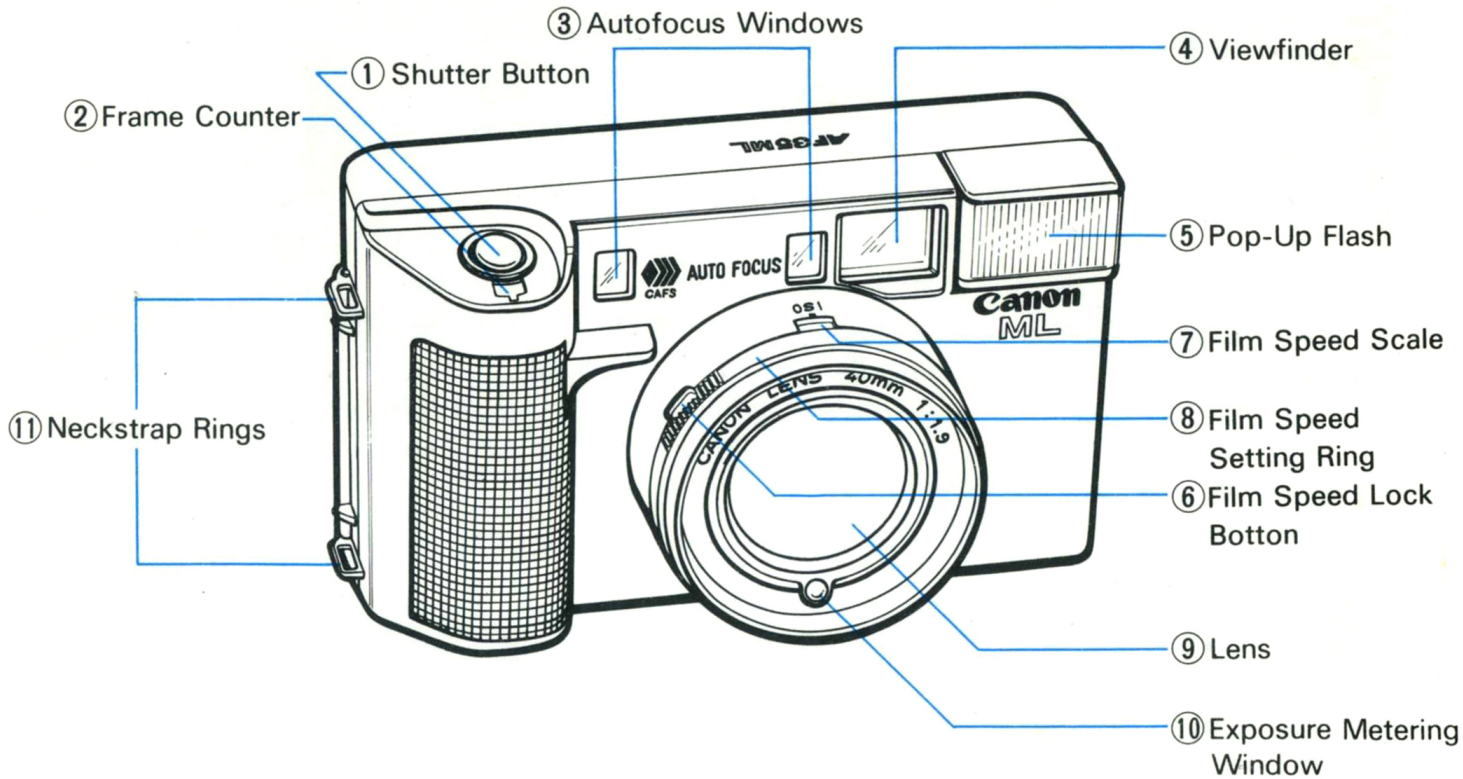

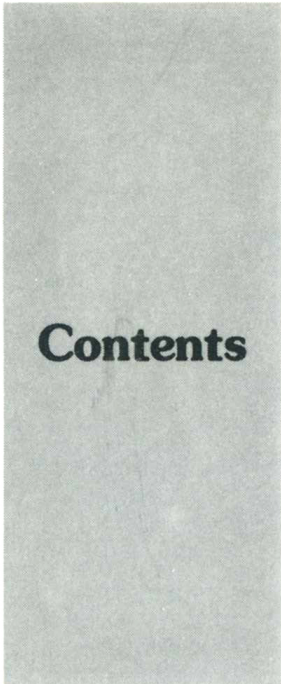

# Contents

- Basic Operation..... 5
- Loading the Batteries..... 6
- Checking the Batteries..... 7
- Loading the Film..... 8
- Setting the Film Speed..... 10
- Tips on Holding the Camera Correctly..... 11
- Shooting..... 12
- Single-frame and Continuous Shooting..... 14
- Using the Self-timer..... 15
- Using the Built-in Flash..... 16
- Rewinding the Film..... 18
- Prefocusing..... 19
- Subjects which Require Special Attention  
in Focusing..... 20
- Using a Filter..... 21
- Attaching the Neckstrap..... 22
- General Hints and Precautions..... 23
- Specifications..... 24

## Basic Operation

1. Load the batteries.
2. Check the batteries.
3. Load the film.
4. Set the film speed.
5. Remove the lens cap.
6. Look into the viewfinder and compose the picture so that the autofocus frame covers your main subject.
7. Press the shutter button halfway. If the camera-shake warning signal beeps, use the built-in flash. Make sure one of the zone-focus symbols lights up.
8. Press the shutter button all the way to take the picture.

## Einlegen der Batterien

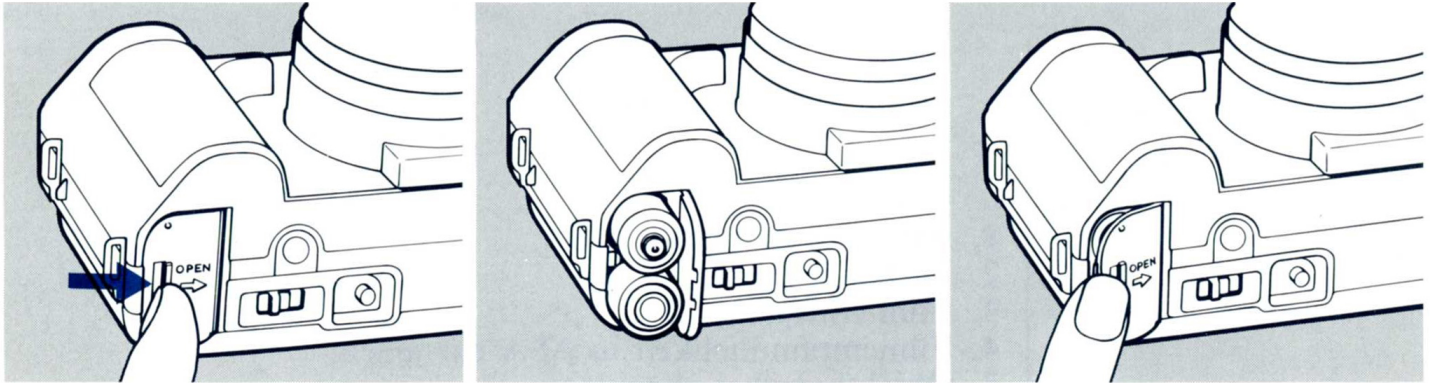

Die Kamera ist nur mit Batterien betriebsbereit. Verwenden Sie zwei frische Mignonzellen 1,5 V des gleichen Fabrikats. Am besten geeignet sind Alkali-Mangan-Batterien. Kohle-Zink-Batterien können gleichfalls verwendet werden, doch sind sie weniger ergiebig. Verwenden Sie **KEINES-FALLS** NC-Zellen!

1. Wischen Sie die Batteriepole mit einem sauberen, trockenen Tuch ab, um einwandfreien Kontakt zu gewährleisten.
2. Schieben Sie den Batteriefachdeckel ② in Pfeilrichtung.
3. Legen Sie die Batterien so ein, daß ihre Pole die im Batteriefach angezeichnete Lage einnehmen.
4. Schieben Sie den Batteriefachdeckel in Pfeilrichtung und drücken Sie ihn nieder.

# Checking the Batteries

1. Turn the mode selector **18** to "B.C" (Battery Check).
2. Shooting is possible if you hear about eight or more "beeps" per second. If the camera beeps slowly and erratically, there is not enough power. In this case, replace the batteries.
3. After checking the batteries, turn the mode selector back to "OFF."

Using new alkaline-manganese batteries at normal temperatures, you can take:

- 1) approximately 30 rolls of 36-exposure film without flash; or

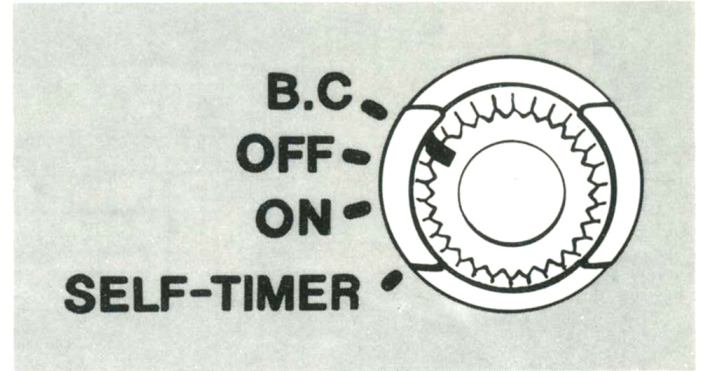

- 2) approximately five rolls of 36-exposure film using flash for each exposure.

When the batteries are running low, auto film advance, power rewinding and flash recycling become slower or stop completely. In this case, replace the batteries.

If you do not expect to use the camera for about three weeks or longer, REMOVE the batteries.

# Loading the Film

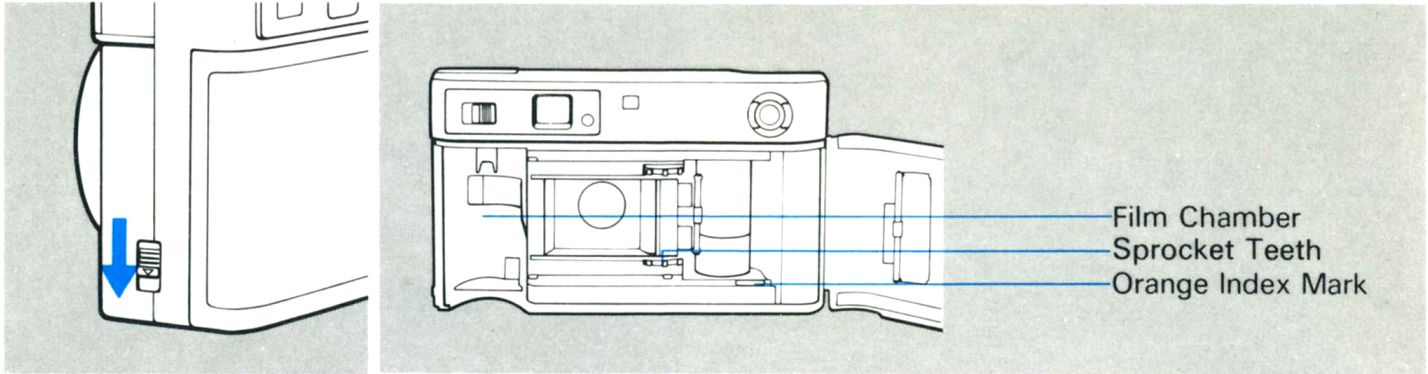

Use color or black-and-white film in standard 35mm cartridges. Shield the film from direct sunlight while loading.

1. Slide the back cover opening latch **12** located on the side of the camera in the direction of the arrow to open the back cover.

2. Insert the upper, flat end of the cartridge into the film chamber first, then lower the other end. The cartridge should be fully seated, not tipped upward.

3. Pull the film leader across the back so that its tip is aligned with the orange index in the lower right-hand side of the film chamber. Occasionally too much of the film leader may be protruding from the cartridge. If the film leader extends past the orange index mark, gently push the excess film back into the film cartridge.

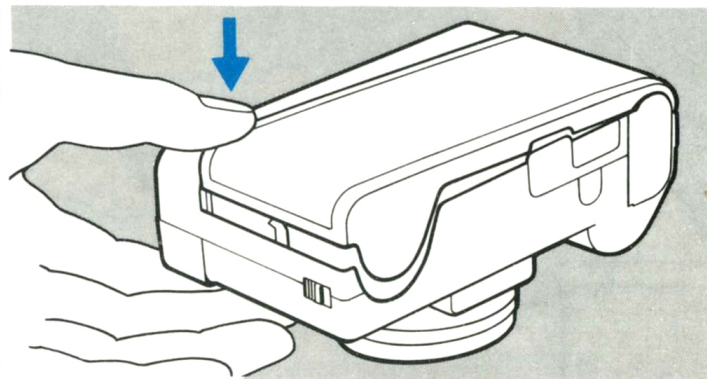
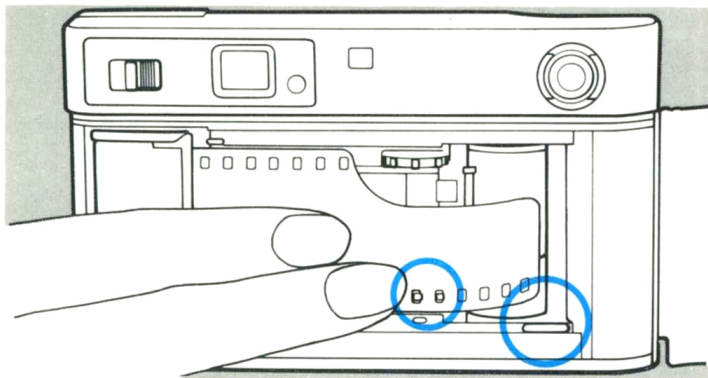

4. Make sure the film perforations are engaged with the sprocket teeth. Then close the back cover.

5. Turn the mode selector **18** to "ON."

6. Press the shutter button **1**, while keeping an eye on the film transport indicator **17**, until the frame counter **2** reaches "1." If the indicator jiggles, the film is transporting properly. If it stays still, open the back cover and reload the film.

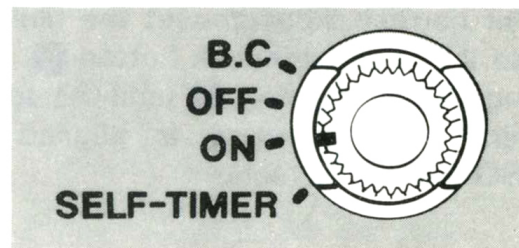

# Setting the Film Speed

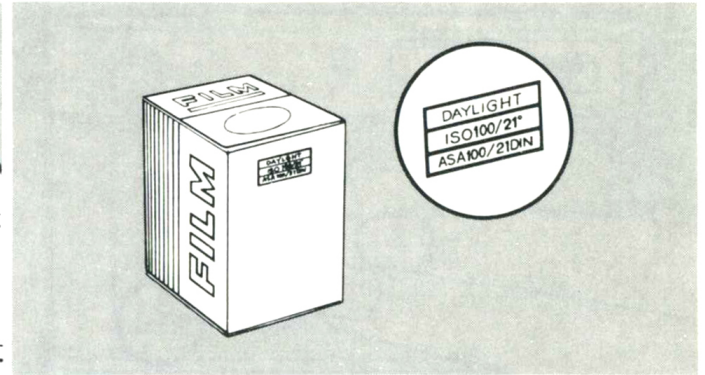
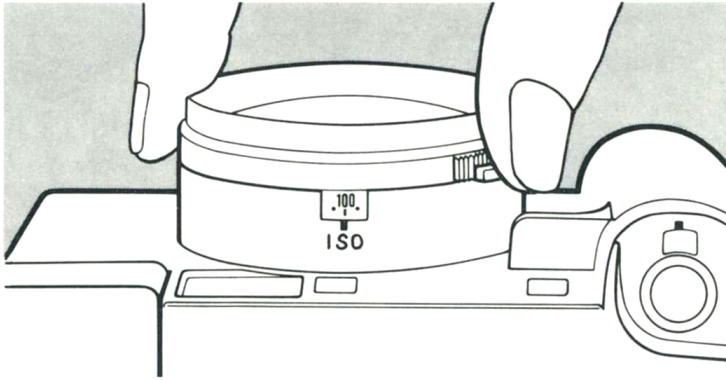

For correct exposure, set the film speed. To do this, press the lock button **6**, while turning the setting ring **8** until the speed of the film you are using is aligned with the ISO/ASA index mark.

## Notes

1. The film speed is marked on the film cartridge and the box by ISO or ASA.
2. Do not forget to reset the film speed each time you load a film with a different ISO/ASA rating.

**ISO/ASA** 50<sup>(64)</sup>(80)100<sup>(125)</sup>(160)200<sup>(250)</sup>(320)400—1000

# Tips on Holding the Camera Correctly



1. Hold the camera firmly in both hands and place your right index finger on the shutter button. Make sure the autofocus window and the lens are not blocked by one of your fingers or any other object.
2. Press at least one of your elbows against your body for stability.
3. Gently press the shutter button all the way down to take the picture.

# Shooting

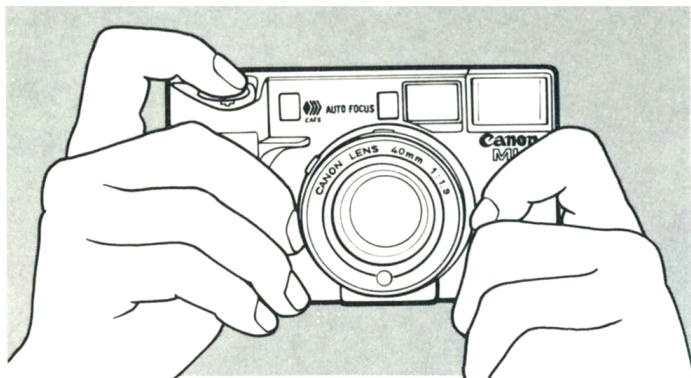

1. Remove the lens cap.
2. Looking into the viewfinder ①, compose the picture so that the autofocus frame covers your main subject. For close subjects between 90cm (3ft.) and one meter (3.3ft.), compose the picture so that the subject is within the parallax correction frame inside the viewfinder. The closest possible shooting distance is 90cm.

## Note

Make sure nothing, such as your finger or hair, is blocking the autofocus windows ② or the lens ③.

3. Gently press the shutter button ① HALF-WAY. If the camera-shake warning signal does not beep and one of the zone-focus symbols lights up, hold the camera steady and gently press the shutter button all the way down.

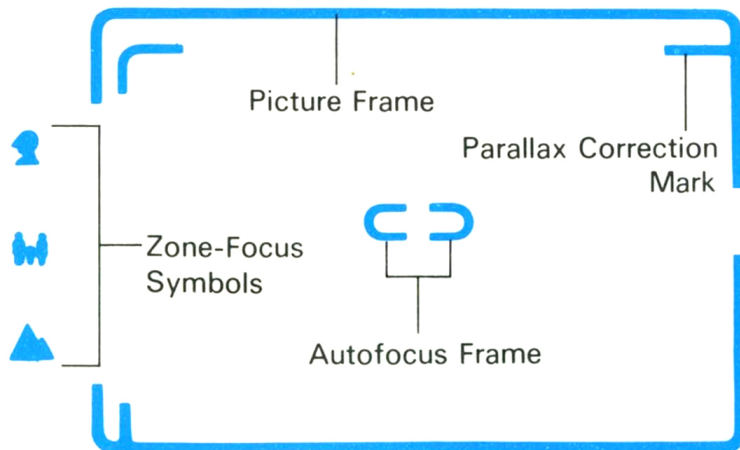

### Notes

1. The camera-shake warning signal beeps to warn of camera movement, which causes blurred pictures. If the warning signal beeps, switch to flash.
2. Three zone-focus symbols (👤 🐕👤 🏔️) are provided in the viewfinder. Each corresponds to the distance of the subject. One should light up when you press the shutter button halfway.
3. The autofocusing system will focus a vast majority of subjects perfectly. A few subjects,

- however, are difficult for the camera to focus and, in this case, a zone-focus symbol will not appear in the viewfinder when you press the shutter button halfway. For details on focusing in this situation, please see pp.20—21.
4. Overexposure may occur if you are using high-speed film, such as ISO/ASA 400, in such extremely bright surroundings as a beach or in snow. In this case, attach a neutral density (ND) filter to the lens to ensure correct exposure.

# Single-frame and Continuous Shooting



advances, the frame counter also advances one frame. It can count up to 36 frames.

## Note

During auto winding, the film transport indicator will jiggle. If the indicator does not move, it means there is no film loaded or, if film is loaded, that it is not advancing correctly. Incidentally, continuous shooting is not possible in flash photography.

The AF35ML advances the film automatically as long as the shutter button is held down, making continuous shooting possible. For a single exposure, you must remove your finger from the shutter button as soon as the shutter is released. If you continue to press the shutter button, the film will be advanced and another exposure made. Each time the film

# Using the Self-timer

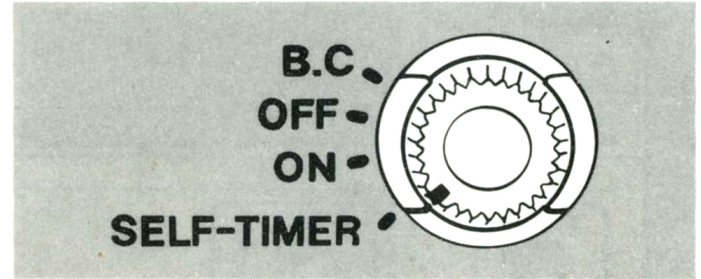

When you would also like to be in the picture, use the self-timer.

1. Turn the mode selector **18** to "SELF-TIMER."
2. Look into the viewfinder **15**, compose so that the autofocus frame covers the subject and press the shutter button **1**. A "beep-beep" sound will be emitted, and the shutter will be released ten seconds later. Two and a half seconds before shutter release, the camera will begin to beep at a faster rate.
3. After you have finished using the self-

timer, turn the mode selector to "ON" or "OFF."

## Notes

1. If you have started the self-timer and wish to cancel it before shutter release, turn the mode selector to "ON" or "OFF."
2. Prefocusing is not possible in self-timer photography (see p. 19).
3. If you are using the self-timer with flash, do not press the shutter button until about five seconds after the flash-ready lamp **16** lights up.

# Using the Built-in Flash

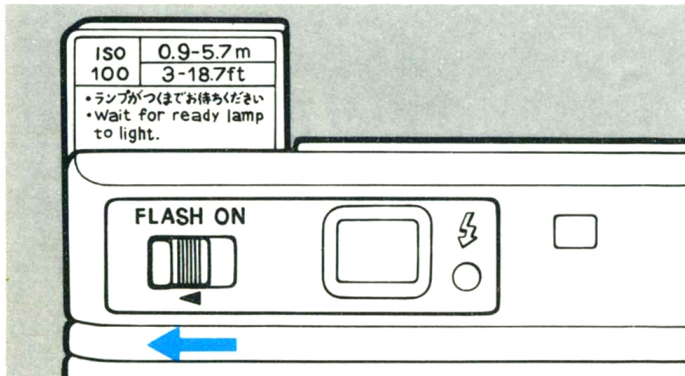

If the camera-shake warning signal beeps when you press the shutter button halfway, use the pop-up flash. If, in this case, you do not use the flash, the picture most likely will be underexposed and blurred.

1. Push the flash switch **14** in the direction of the arrow; the built-in flash **5** will pop up.
2. Wait for the flash-ready lamp **16** to light up before you press the shutter button.

## Note

If you press the shutter button before the flash-ready lamp lights up, the picture may be too dark. Also, do not press the shutter button continuously while waiting for the flash-ready lamp

to light; otherwise, the flash will not charge.

3. Looking through the viewfinder **15**, compose the picture so that your subject covers the autofocus frame. After composing the picture, do not try to expose the picture right away. First, press the shutter button halfway and watch for the appearance of one of the zone-focus symbols. When the zone-focus symbol does not light up in the viewfinder, it means automatic focusing has ceased to function due to a very low ambient illumination. Under such a situation, camera focuses only to a distance range of approximately two to three meters (6.7 to 10 ft.) and the flash accordingly achieves lighting only for that range. Therefore, when none of the zone-focus symbols lights up, place your subject within the aforementioned range and then shoot using flash.

4. To switch back to normal photography, simply push the flash down so that it locks in place. Keep the flash pressed down when it is not being used. If it is left popped up, the batteries will eventually drain.

## Notes

1. The shooting distance within which the flash may be used is 0.9 to 5.7m (3 to 19 ft.) with ISO/ASA 100 or faster film when there is sufficient amount of existing light over the subject. As sure means of knowing that the camera will automatically focus on the subject for a flash picture, one of the zone-focus symbols lights up in the viewfinder at the half pressure of the shutter button. As provided by information on page 16, shooting distance for flash photography becomes more or less fixed when the ambient illumination is very low.
2. Continuous shooting is not possible while using the flash.
3. If there is light, such as a window, behind your subject, your subject may turn out too dark in the picture. In this case, the flash can be used to lighten the subject by "filling in" the shadows provided the backlight is not extremely bright.



# Rewinding the Film

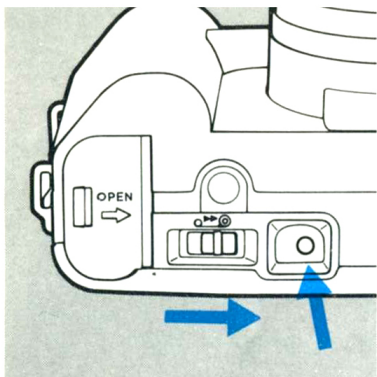

At the end of the roll of film, film advance will stop automatically and, after a pause of about two seconds, the camera will beep for about five seconds to inform you. If you do not remove your finger from the shutter button after film advance stopped, the camera will continue to beep until you let go of the shutter button.

DO NOT open the back cover until the film is completely rewound.

1. Press the film rewind button ⑰ while sliding the film rewind switch ⑱ in the direction of the arrow. The film transport indi-

cator ⑰ will jiggle and the frame counter ② will count backwards while the film is being rewound.

2. When the film transport indicator stops moving, push the film rewind switch back to its original position.

3. Be sure to shield the film from direct sunlight while unloading. Then slide the back cover opening latch ⑫ in the direction of the arrow and open the back cover.

4. Remove the film cartridge from the film chamber.

## Note

Make sure the mode selector ⑮ is set to "ON" during automatic winding and power rewind, and turn it to "OFF" when you are not using the camera.

# Prefocusing

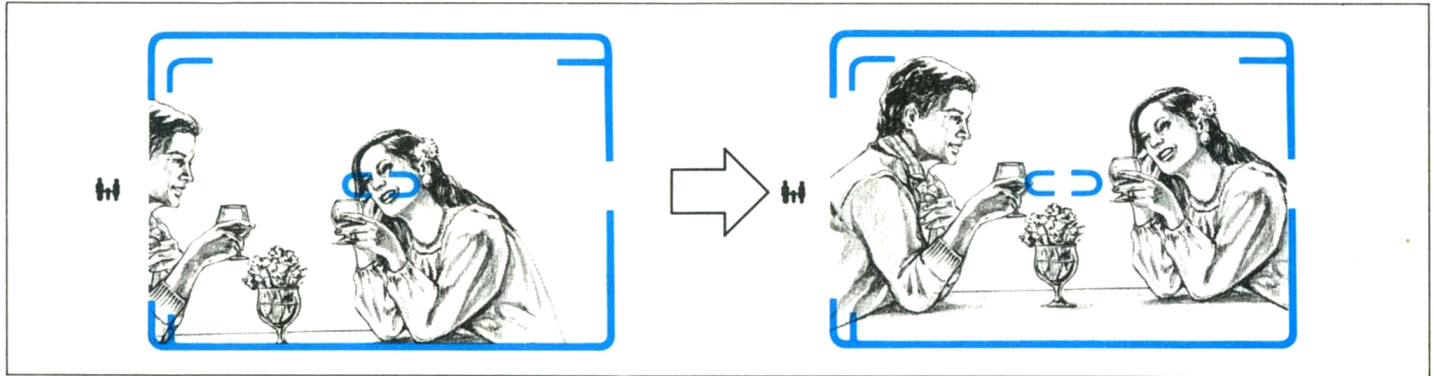

When you wish to compose the picture so that your subject is not in the center of the viewfinder and the autofocus frame is, therefore, not covering the subject, follow these steps:

1. Look into the viewfinder and compose the picture so that the autofocus frame covers your subject. Gently press the shutter button HALFWAY and make sure one of the zone-focus symbols lights up. This allows the camera to "memorize" the subject distance.
2. Keeping the shutter button pressed half-way, recompose the picture as you like, but

do not change the shooting distance.

3. Press the shutter button all the way down to take the picture.

# Subjects which Require Special Attention in Focusing

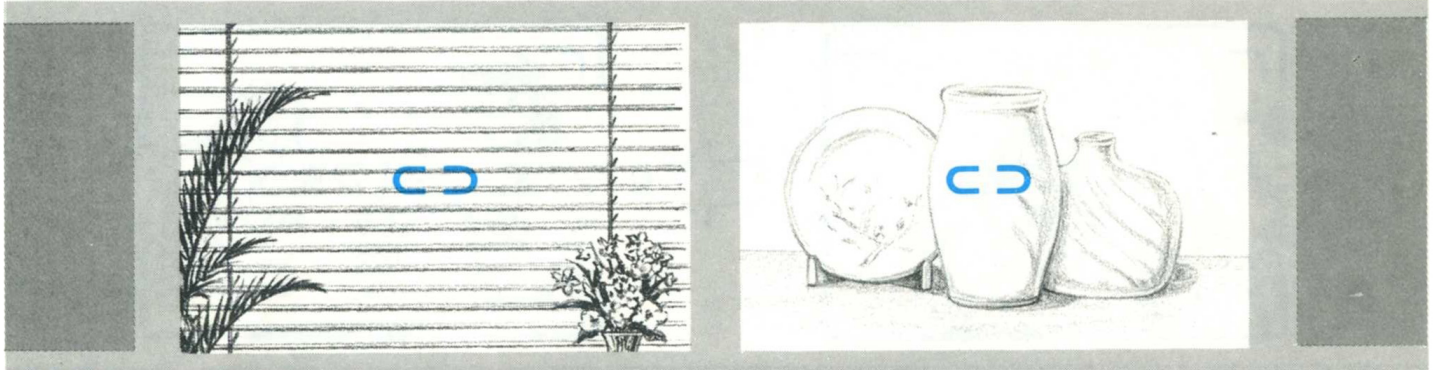

The following subjects are difficult for the autofocus system to focus exactly:

1. Subjects without vertical lines (window blinds, a series of waves in the ocean).
2. Subjects with little or no contrast (light-colored or white objects).
3. Subjects with an object in front of them. (zoo animals in a cage).
4. Subjects with strong reflections or brightly backlit subjects.
5. Subjects composed of very small, uniform parts (a patch of grass or a bed of very small flowers).

6. Subjects in low-light situations (usually noted by the camera-shake warning signal).

The method below is usually effective for focusing the above subjects:

1. Compose the picture so that the autofocus frame covers a substitute subject with a high contrast which is approximately the same distance as your main subject. Then press the shutter button halfway, making sure one of the zone-focus symbols lights up in the viewfinder.

# Using a Filter

2. Keeping the shutter button pressed half-way, recompose the picture so that your subject is where you want it to be, and press the shutter button all the way to take the picture.

A 48mm-diameter filter may be screwed into the front ring of the lens ⑨. Since light passes through the filter before it reaches the exposure metering window ⑩, no exposure correction is necessary. The procedure for taking pictures with a filter attached is the same as for normal photography.

A UV or skylight filter is recommended for flash photography. It will also protect the surface of the lens.

# Attaching the Neckstrap

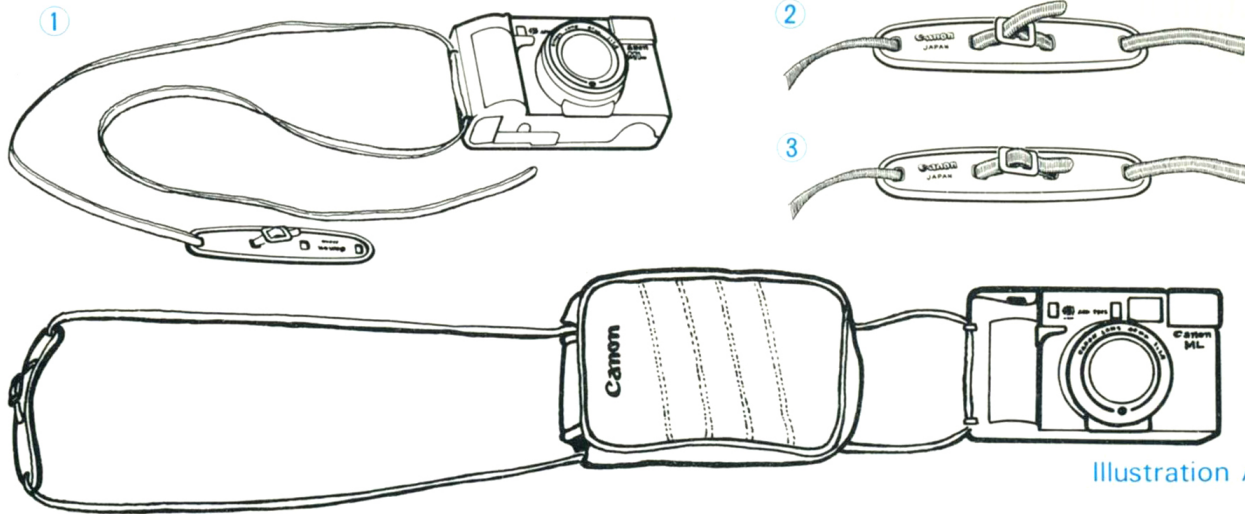

Attach the neckstrap to the camera attachment rings as shown, and adjust the shoulder pad until it is in the center of the strap. The camera may be used with the case attached, as shown in Illustration A. Also, a pocket is provided to carry two spare batteries as shown in Illustration B.

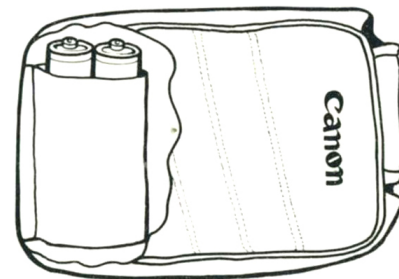

# General Hints and Precautions

1. Attach the lens cap to protect the lens whenever you are not shooting.
2. Keep the camera clean. For the glass surfaces of the camera, obtain a blower brush and cleaning fluid and tissue made specially for camera lenses. First blow off dust with the blower brush. Then moisten the tissue with a couple of drops of lens-cleaning fluid and gently wipe the surface from center to edges in a circular motion. For non-glass surfaces, brush off dust with a blower brush. Then wipe off smudges with a silicone cloth or chamois leather. Never use such cloths on the glass surfaces. The film compartment also requires gentle cleaning with a blower brush from time to time to remove film dust which may scratch the film.
3. The best thing you can do for your camera is to use it regularly. If you must store it for quite a while, first remove the batteries. Then wrap the camera in a clean, soft cloth and store it in a cool, dry, dust-free area. Always keep the camera out of direct sunlight and

very hot areas, such as the trunk or glove compartment of a car. Keep it out of humid and dusty places.

4. Water, spray, excessive humidity and sand are your camera's worst enemies. Clean it especially well immediately after you use it at the beach.

5. The battery does not work well at very low temperatures (below 0°C, 32°F). If you plan to shoot in cold conditions, keep the camera warm until just before you shoot. It is a good idea to carry spare batteries; keep them warm also until they are needed.

6. Replace the batteries every year even if they are not used since they will discharge gradually.

# Specifications

**Type:** 35mm lens-shutter camera with automatic film loading, automatic film advance, power film rewind, automatic exposure and automatic focus.

**Lens:** Canon 40mm f/1.9. Construction: Five elements in five groups.

**Focusing:** Canon Solid-State Triangulation (S.S.T.) autofocus system.

**Shooting Distance Range:** 0.9m (3 ft.) to infinity ( $\infty$ ).

**Filter Thread Diameter:** 48mm

**Automatic Exposure Coupling Range:** EV 4 (f/1.9 at 1/4 sec.) to EV 17 (f/18 at 1/400 sec.) with ISO 100/21°, ASA 100 film.

**Shutter:** Programmed electromagnetic shutter; also serves as diaphragm blades.

**Viewfinder:** Albada viewfinder with finder frame and parallax correction frame for close focusing. 0.5X magnification. 85% vertical and horizontal coverage of actual picture area. Information includes picture frame (1m— $\infty$ ), parallax correction frame (0.9m—1m), autofocus frame, zone-focus symbols.

**Camera-shake Warning Signal:** Electronic beeper

**Film Loading:** Automatic film loading by aligning film leader with orange index mark in film chamber. Film wound emulsion side in.

**Back Cover:** Opened by pressing back cover latch.

**Film Advance:** Electromotive. Winding automatic by pressing and then releasing shutter button for exposure.

**Continuous Photography:** By keeping the shutter button depressed.

**Film-end Indicator:** Electronic beeper after film advance stops automatically.

**Film Rewinding:** Automatic upon pressing rewind button and pushing power rewind switch. Indicated by film transport indicator and frame counter.

**Frame Counter:** Additive type; automatically resets to "S" by opening back cover. Counts back with film rewind.

**Prefocus:** By pressing shutter button halfway.

**Self-timer:** By turning mode selector to self-timer position. Activated by pressing shutter button. Ten-second delay with electronic "beep-beep" sound. Number of beeps emitted per second increases 2.5 seconds before shutter release. Cancellation possible.

**Film Speed Scale:** ISO/ASA 50—1000

**Built-in Flash:** Pop-up type.

**Guide Number:** 11 (ISO100/21°, ASA100•m) or 18 (ISO25/15°, ASA25•ft.)

**Flash Recycling Time:** Less than seven seconds

(interval between firing of flash and relighting of flash-ready lamp) with new alkaline-manganese batteries.

**Flash Duration:** Less than 1/1000 sec.

**Battery Life:** Using new alkaline-manganese batteries at normal temperatures:

Without flash: approximately 30 rolls of 36-exposure film.

Using flash for each exposure: approximately 5 rolls of 36-exposure film

**Power Source:** Two size-AA 1.5V alkaline-manganese or carbon-zinc batteries. (Ni-Cd batteries cannot be used.)

**Dimensions:** 121.5(W) x 72.6(H) x 55.3(D) mm  
(4-13/16" x 2-7/8" x 2-3/16")

**Weight:** 440g (15-1/2 ozs.) with batteries.

*Subject to change without notice.*

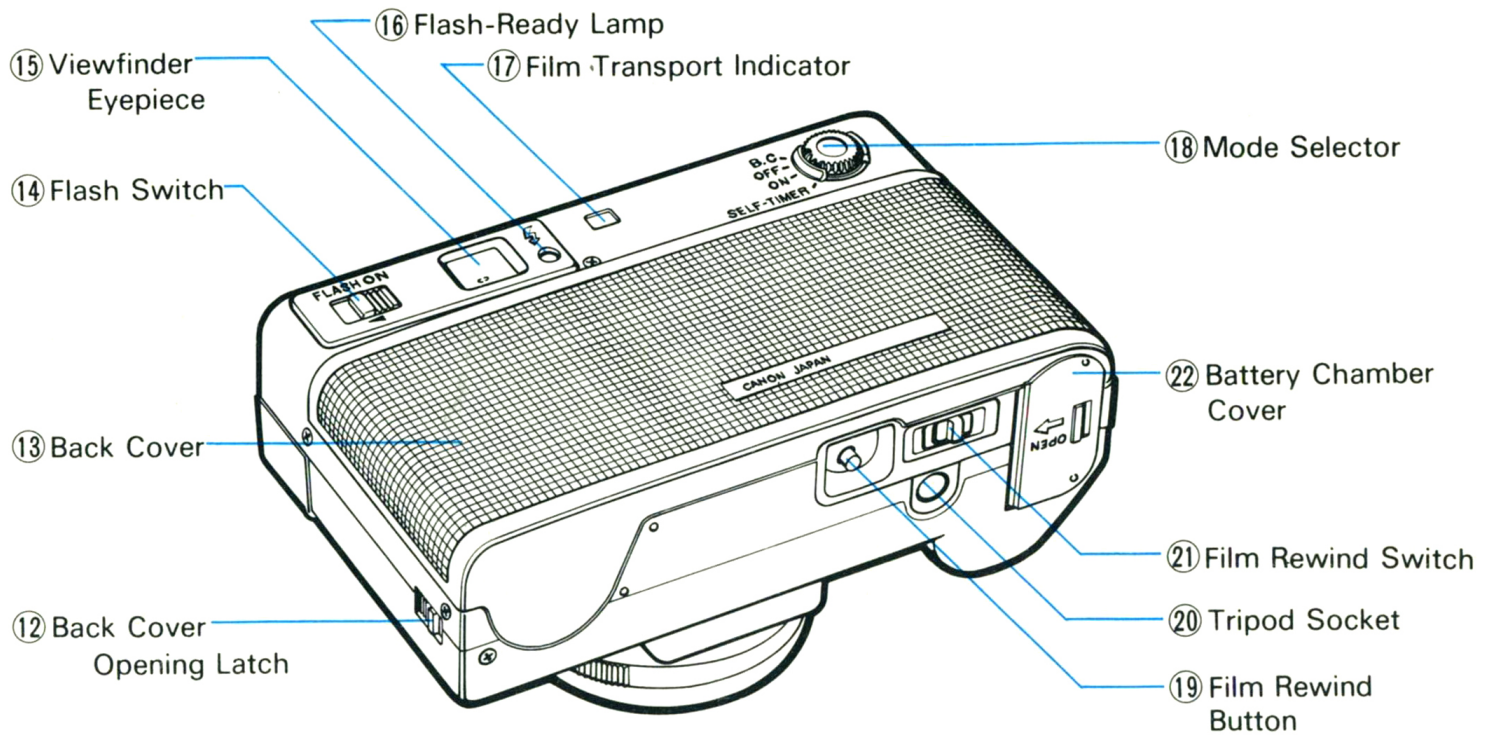



# Canon

**CANON INC.** 7-1, Nishi-Shinjuku 2-Chome, Shinjuku-ku, Tokyo 160, Japan  
Mailing address: P.O. Box 5050, Dai-ichi Seimei Building, Tokyo 160, Japan

U.S.A. ————— **CANON U.S.A., INC. HEADQUARTERS**  
One Canon Plaza, Lake Success, N.Y. 11042, U.S.A.  
**CANON U.S.A., INC. MANHATTAN SERVICE CENTER**  
600 Third Avenue, New York, N.Y. 10016, U.S.A.  
**CANON U.S.A., INC. ATLANTA BRANCH**  
6380 Peachtree Industrial Blvd., Norcross, Georgia 30071, U.S.A.  
**CANON U.S.A., INC. CHICAGO BRANCH**  
140 Industrial Drive, Elmhurst, Illinois 60126, U.S.A.  
**CANON U.S.A., INC. LOS ANGELES BRANCH**  
123 Paularino Avenue East, Costa Mesa, California 92626, U.S.A.  
**CANON U.S.A., INC. LOS ANGELES SERVICE CENTER**  
3321 Wilshire Blvd., Los Angeles, California 90010, U.S.A.  
**CANON U.S.A., INC. SANTA CLARA BRANCH**  
4000 Burton Drive, Santa Clara, California 95050, U.S.A.  
**CANON U.S.A., INC. DALLAS OFFICE**  
2035, Royal Lane, Suite 290, Dallas, Texas 75229, U.S.A.  
**CANON U.S.A., INC. HONOLULU OFFICE**  
Bldg. B-2, 1050 Ala Moana Blvd., Honolulu, Hawaii 96814, U.S.A.

CANADA ————— **CANON CANADA INC. HEADQUARTERS**  
6390 Dixie Road, Mississauga, Ontario L5T 1P7, Canada  
**CANON CANADA INC. MONTREAL SERVICE CENTRE**  
10652 Côte de Liesse, Lachine, Quebec H8T 1A5, Canada  
**CANON CANADA INC. CALGARY OFFICE**  
2828, 16th Street, N.E. Calgary, Alberta T2E 7K7, Canada

EUROPE, AFRICA  
& MIDDLE EAST ————— **CANON EUROPA N.V.**  
P.O. Box 7907, 1008 AC Amsterdam, The Netherlands  
**CANON FRANCE-PHOTO CINEMA S.A.**  
30, boulevard Vital-Bouhot, Ile de la Jatte, 92521 Neuilly-sur-Seine, France  
**CANON UK LTD.**  
Units 4 & 5, Brent Trading Centre, North Circular Road, London NW10 0JF, United Kingdom

CENTRAL &  
SOUTH AMERICA ————— **CANON LATIN AMERICA, INC. DEPTO. DE VENTAS**  
Apartado 7022, Panama 5, Republica de Panama  
**CANON LATIN AMERICA, INC. CENTRO DE SERVICIO Y REPARACION**  
Apartado 2019, Zona Libre de Colon, Republica de Panama

SOUTHEAST ASIA ————— **CANON HONGKONG TRADING CO., LTD.**  
Golden Bear Industrial Centre, 7/F., 66-82 Chai Wan Kok Street,  
Tsuen Wan, New Territories, Hong Kong  
**CANON SINGAPORE PTE. LTD.**  
60-B Martin Road, #10-01/08, Singapore Warehouse, Block C, Singapore 0923

OCEANIA ————— **CANON AUSTRALIA PTY. LTD.**  
Unit 1/37, Waterloo Road, North Ryde (Macquarie Park), N.S.W. 2113, Australia

JAPAN ————— **CANON SALES CO., INC.**  
11-28, Mita, 3-Chome, Minato-ku, Tokyo 108, Japan

PUB. C-1E-086T  
0485M08

©CANON INC. 1981  
CY8-6021-002

PRINTED IN TAIWAN