

SUPER SOLINA
2107/939

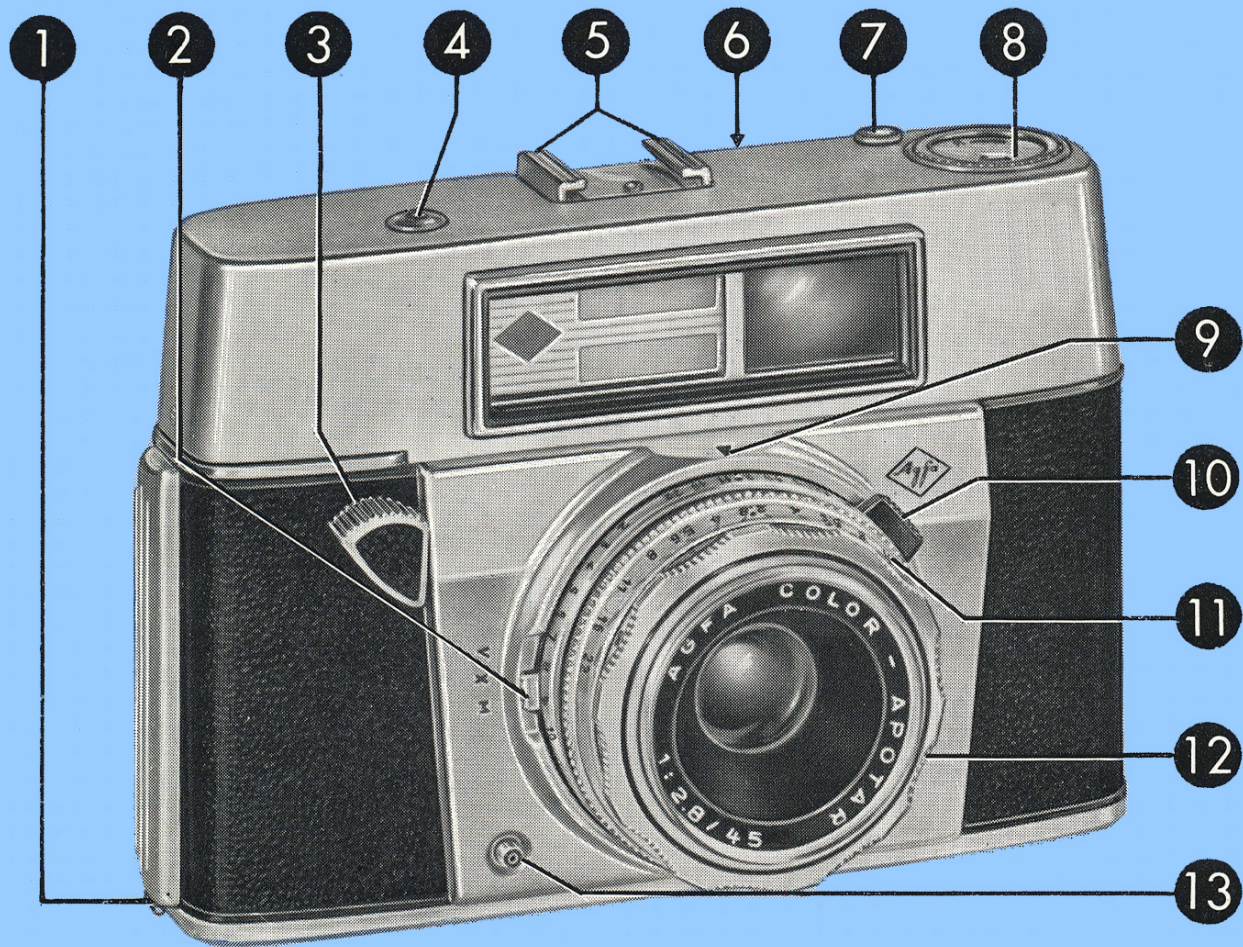



- ① Catch for camera back
- ② Flash and delayed action selection lever
- ③ Shutter release
- ④ Cable release connection
- ⑤ Accessory shoe
- ⑥ Viewfinder eyepiece
- ⑦ Locking button
- ⑧ Rewinding knob with film type indicator
- ⑨ Diaphragm setting mark
- ⑩ Exposure value setting key
- ⑪ Depth of field scale
- ⑫ Focusing ring
- ⑬ Flash socket

ALPHABETICAL LIST OF CONTENTS

	Page		Page
Accessories	24-25	Flash synchronization	12-13
Delayed action release	18	Holding the camera	14-15
Depth of field	16	Loading the camera	20-21
Depth of field table	26-27	Photographic hints	23
Double and blank exposure lock	21	Rangefinder	6-7
Exposure value	8-9	Rewinding the film	22
Film counter	3	Short guide	28
Film tips	18-19	Shutter speeds and apertures	10-11
Film transport	4	Snapshot setting	17
Film type indicator	2	Time exposures	12

The lens fitted to your camera is a product of the Agfa Camera Werk and has been computed and manufactured in conformity with the most up-to-date scientific methods.

This lens reaches a standard of performance never previously attained in lenses of equal speed having the same number of elements. Its chief advantages lie in its great depth of field, extremely high resolving power, excellent definition and outstanding reproduction of detail.

The total of these characteristics makes this the ideal lens for miniature photography with black and white or colour film.

In addition, every lens is thoroughly tested before leaving our factory by the most up-to-date methods and is guaranteed by us for its quality and performance.

*AGFA AKTIENGESELLSCHAFT
Camera-Werk Muenchen*

AT LAST YOU HAVE REALIZED YOUR AMBITION

by becoming the owner of a new precision miniature camera, the Agfa Super Solina. You are to be congratulated on your choice and we wish you many happy hours of relaxation with your camera.

Your Agfa Super Solina offers you the following special advantages:

- a coupled rangefinder,

- bright-line viewfinder,

- exposure value shutter,

- and a high-speed colour-corrected anastigmatic lens of maximum definition.

We know that you are eager to learn more about this fine camera, and so we suggest that you read through this little booklet and familiarize yourself with your Super Solina.

Your photographic dealer may have helped you to "load" the first film in the camera. Films for 35 mm. miniature cameras are wound on a spool enclosed in a light-tight cassette and contain either 36 or 20 exposures, the actual size of the picture being 24 x 36 mm. There is a wide selection of different types of films available, and further details of these are given on pages 18/19. If you have not been shown how to load the camera, instructions are contained on pages 20/21.

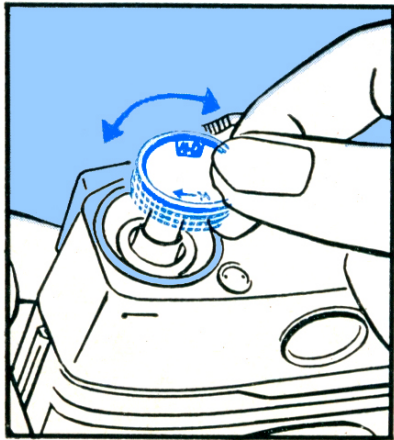
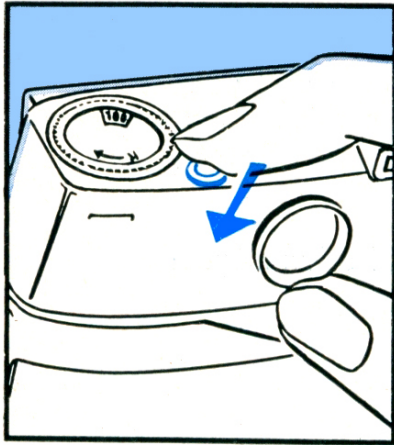

FILM TYPE INDICATOR

The Super Solina is provided with a film type indicator so that you always know what film is in the camera. It should be set when inserting the film. To do this, push the small button in the direction of the arrow (see illustration) and the rewinding knob will automatically spring upwards. Now pull out this knob as far as it will go and grasp the disk between thumb and forefinger (see illustration). The disk can be set with the forefinger by its milled edge protruding at the bottom until the desired symbol appears in the window. The disk is rotatable in both directions.

The numbers 20, 40, 100, 250 represent the film speed values in ASA ratings for black and white film which is quoted on every film carton.

If you are using colour negative film, provision is made for the following settings:

CN = Colour negative film,

CN 17 = Agfacolor negative film for daylight and artificial light.

When loading a colour reversal film for transparencies, you should use one of the following settings:

- CK
A = Colour reversal film, artificial light type (incandescent lamps with 3400° Kelvin)
- CF
F = Colour reversal film, artificial flashlight type (3800° Kelvin)
- CT
DAY = Colour reversal film, daylight type

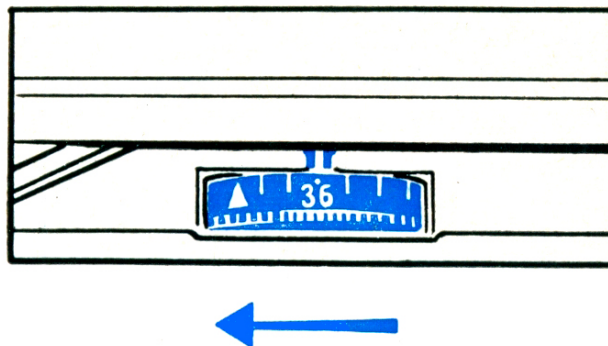

FILM COUNTER

After loading the camera, the film counter underneath the camera should be set to the starting position.

To do this, turn the milled ring in the direction of the arrow (see illustration) so that the fixed mark is opposite the green triangle. When using a cassette with 36 exposures this is done by setting the scale to the green triangle between 36 and 0, for films with 20 exposures the green triangle between 25 and 20. The camera is ready for the first exposure after transporting the film to bring this number (i. e. 36 or 20) opposite the fixed setting mark (see illustration). The film counter indicates **the number of exposures you still have left on the film.**

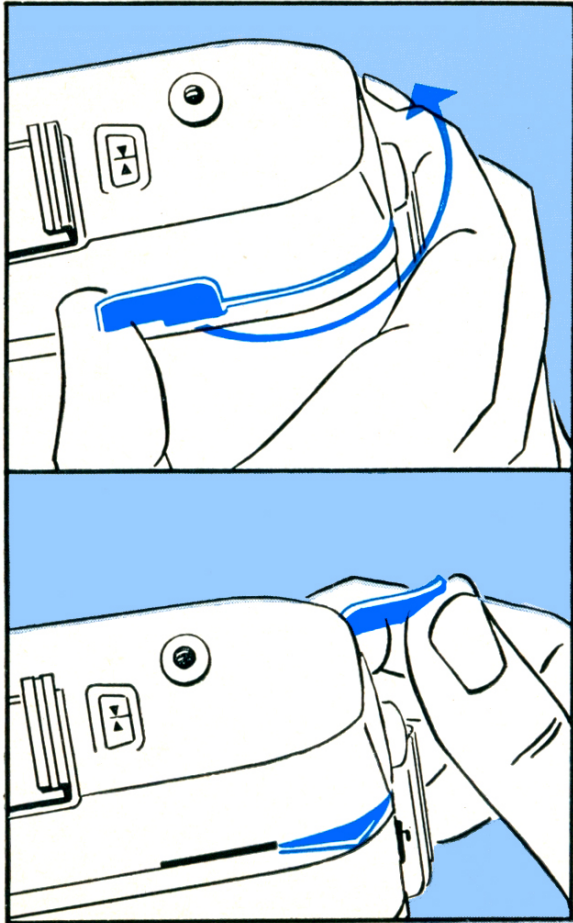

FILM TRANSPORT

When loading the camera the start of the film is wasted by exposure to light and so you must first make two blank exposures.

The rapid transport lever moves the film on one frame each time it is operated. Place your thumb behind this lever and swivel it round as far as possible. If the lever is blocked you will have to press the shutter release first. You should repeat this operation of film transport and shutter release twice at the start of every new film before the camera is ready for use.

If you inadvertently release the rapid transport lever before it reaches its stop, you must swivel it round again until it reaches a stop which may lie half way; do not try to force it through.

Caution! The rewinding knob turns as the film is transported and should therefore not be hindered in any way.

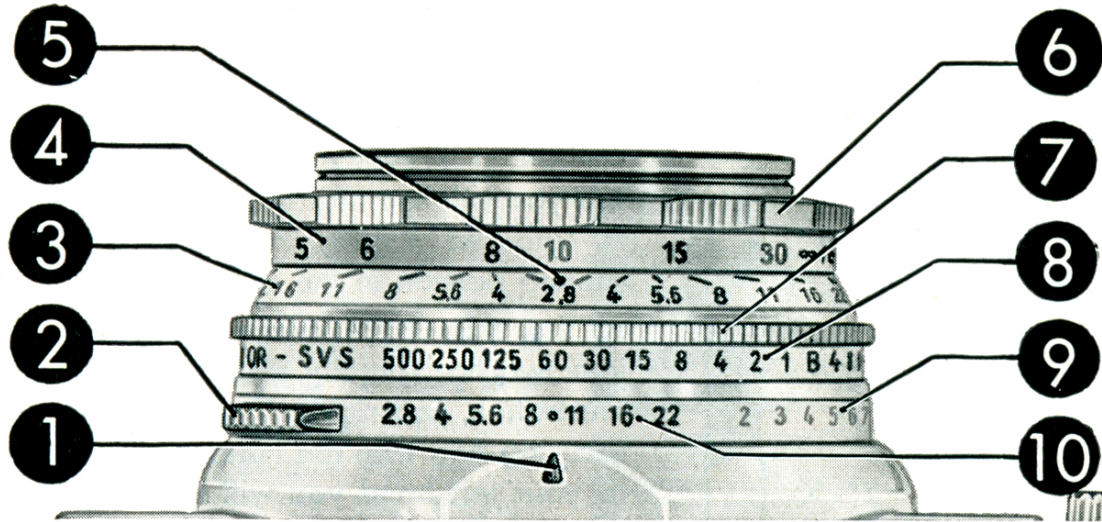

- ① Setting mark for shutter speed and aperture combination
- ② Exposure value setting key
- ③ Depth of field scale
- ④ Feet ring
- ⑤ Focusing mark

- ⑥ Focusing setting ring
- ⑦ Milled ring to set shutter speed and aperture combination
- ⑧ Shutter speed scale
- ⑨ Exposure value scale
- ⑩ Aperture scale



THE RANGEFINDER

Focusing is very simple with the aid of the built-in, coupled rangefinder. Through the viewfinder eyepiece at the back of the camera you will see that the entire field of view is coloured slightly and has a diamond-shaped portion in the centre.

At first this centre image will be separated into two horizontally displaced outlines (see illustration, top right). If you now move the focusing ring with the index or middle finger of your left hand you will find that the outlines of the double centre image converge (lower illustration). When this point is reached, the object is automatically in focus. You can rely implicitly on the accuracy of the rangefinder which takes the guess work out of focusing.

With the camera held horizontally the image outlines move sideways, when held upright they move vertically.

A useful tip:

Place your finger over the right viewfinder window at the front of the camera. You will find that the viewfinder image is no longer coloured and is more suitable for lining up your subject. When you want to focus the camera with the rangefinder you can remove your finger; by this method the double outlines are more clearly visible.

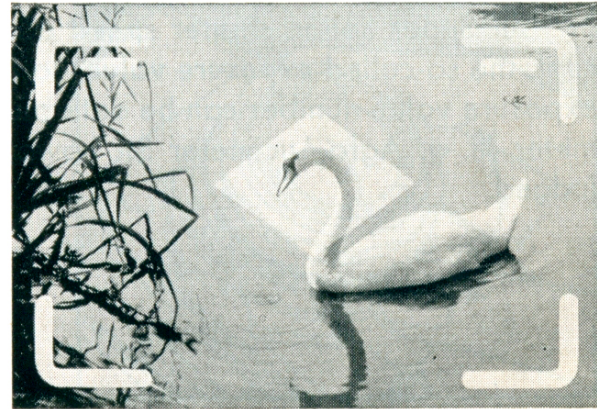
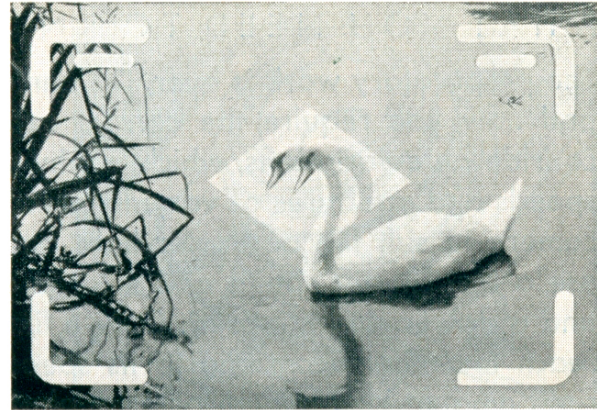

WHAT YOU NEED TO KNOW . . .

The preparatory work is over, the camera has been focused with the rangefinder and now you require the correct exposure. Lighting conditions are subject to considerable variations, which is why your camera is fitted with different shutter speeds and apertures of varying size. With both these means you can adjust the camera to suit the particular light and subject. For moving objects it is best to use a fast shutter speed and a large aperture, for landscapes a small aperture and a slower shutter speed. Only a limited amount of light should be allowed to reach the film—according to its speed—and so it is up to you to see that the right amount is obtained for each photograph.

In your Super Solina shutter speed and stop have been combined into one concept, the so-called **exposure value**, so that you have to set one number only. This exposure value number can be determined by means of a photo-electric exposure meter (e. g. Agfa Lucimeter S); however, with some experience it can also be judged.

... AND HOW TO DO IT

The exposure value is set by depressing the black exposure value key (see illustration) towards the centre of the lens and at the same time rotating the stop ring until the exposure value number determined or guessed (red scale) faces the setting mark (see upper illustration). The key is then released whereby a firm connection is established between diaphragm stop and shutter speed ring.

From now on the exposure value setting should not be altered and only the milled shutter speed ring may be turned (see lower illustration).

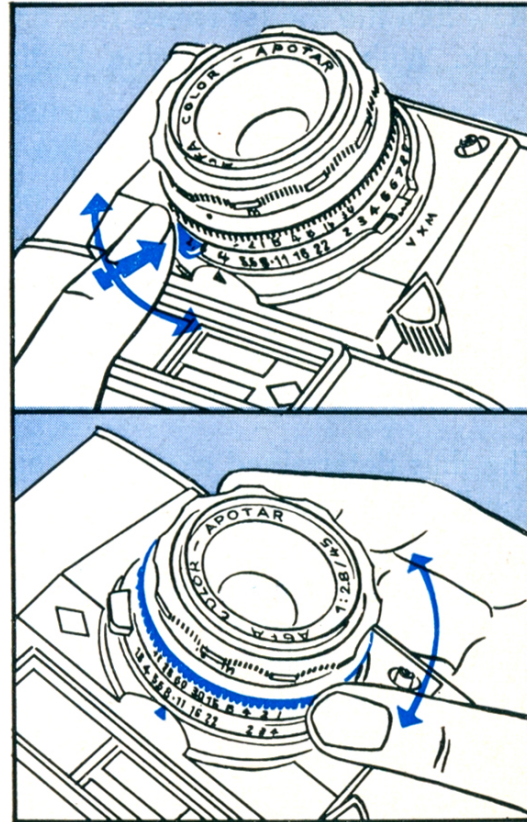

Now turn the shutter speed ring and set the exposure time opposite the triangular mark. With exposure value 12 the following combinations are then possible:

Stop	f. 2.8	4	5.6	8	11	16	22
Shutter speed	$1/500$	$1/250$	$1/125$	$1/60$	$1/30$	$1/15$	$1/8$

Each of these shutter speed and stop combinations allows an equal amount of light to reach the film and so you only need to select the one best suited to your subject by turning the large milled ring to the triangular mark (①, see illustration, page 5). To be sure of choosing the correct combination it is advisable to read the chapter on page 11 carefully.

The thus determined exposure value setting can be used as long as the lighting conditions remain the same.

Let us once more summarise the most important points of this chapter: Determine and set the exposure value, release exposure value key, turn the milled ring to set the pictorially most favourable combination opposite the triangular mark; then the camera will be ready for action.

WHICH IS THE BEST SHUTTER SPEED AND APERTURE COMBINATION?

If you wish to photograph a landscape with both foreground and background in focus, you must use a small aperture (for example, f. 8 and $1/60$ sec. as shown on the previous page). Longer exposure times such as $1/30$, $1/15$, and $1/8$ sec. cannot normally be used without a tripod, because of camera shake.

For a quickly moving object on the other hand you should use a fast shutter speed to avoid blurring (such as $1/500$ sec. and f. 2.8, shown on the previous page).

In the first case a slower shutter speed is chosen in favour of a small aperture and in the second case a larger aperture is selected to enable the use of a faster shutter speed.

You may sometimes obtain exposure value readings on the exposure meter which lie between two numbers. These can also be set on the camera with the diaphragm ring, but shutter speeds should never be set so that the triangular mark lies between two speeds. You can easily avoid this, however, because each setting on the large milled ring has a click stop.

FOR VERY POOR LIGHTING

Sometimes there is not enough light to give an exposure meter reading on any of the instantaneous shutter speeds. Then you use the "B" shutter setting for time exposures.

In such cases place the camera on a firm support, preferably on a tripod, attach a cable release (if possible with time lock) to the connection provided and make the exposure. The shutter stays open as long as pressure is exerted on the cable release button.

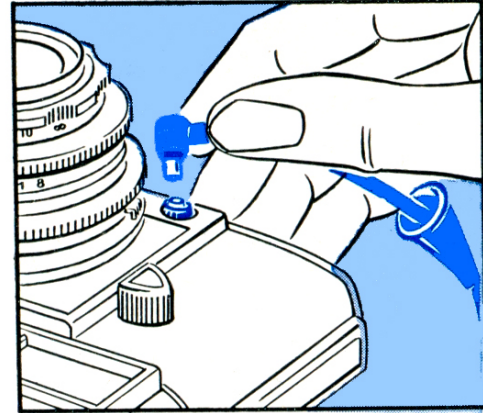

In many cases, particularly with indoor photography, a flashgun will be needed to supplement the available light and for this your Super Solina is provided with a flash contact. You merely slide the flashgun (such as the Agfa KM or Agfalux flashgun) on to the accessory shoe of the camera and attach the flash lead to the contact (see illustration).

When looking onto your Super Solina from above you will see a small lever on the right which according to the flash method used should be set to X or M.

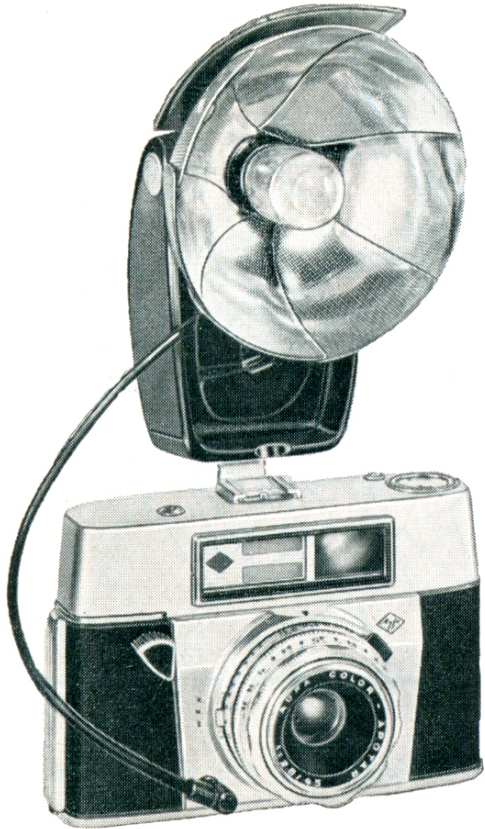

Note therefore:

With the **X-synchronisation**—position of lever to X (or with delayed action to V) speeds no faster than $1/30$ must be used. With the **syn-**
chronizing lever set to M faster shutter speeds can be used.

The apertures required are given in instructions attached to each flash bulb carton.

When using an **electronic flashgun** the lever must always be set to **X**. Contrary to flashbulbs **any** shutter speed can be used. Apertures are calculated from the **guide numbers** for the flashgun concerned, e. g. guide number 96 divided by a distance of 12 feet = aperture f. 8. The electronic flashgun can be used for black and white or **daylight** colour films.

HOLDING THE CAMERA

Hold the camera steady to obtain sharp results. We advise you to take your Super Solina in both hands and from an angle with your arms against your body. Your thumbs should lie along the back of the camera with the forefinger of your right hand on the shutter release. Line up your subject in the viewfinder. Everything within the luminous frame area will appear on the picture. If you can see only part of the frame, this indicates that you are tilting the camera or not looking through the centre of the viewfinder. As soon as you are satisfied with what you see, press the shutter release; this is done by slowly pressing down the release lever as far as possible with your finger tip. For subjects nearer than 7 feet use the two short lines (see illustration, page 7) as the upper limit of the subject, and tilt the camera slightly upwards.

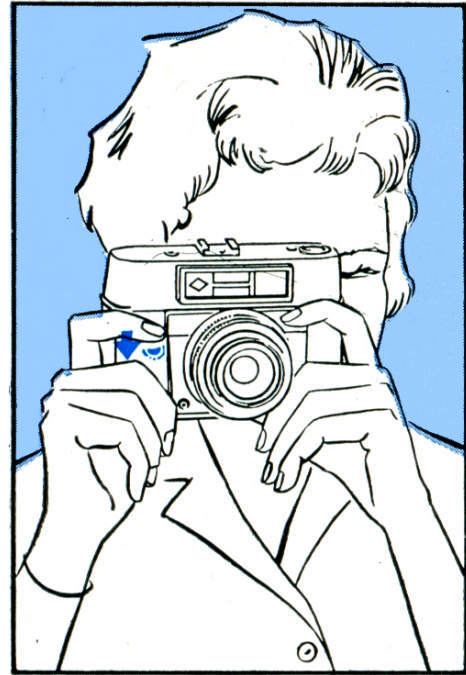



Give it a trial with your very first photograph: Don't forget to hold the camera level and **as close to your eye as possible**. It does not matter which eye you use for viewing the subject, the main thing is to close your other eye. Then take a deep breath, hold it, and press the shutter release.

When holding the camera upright turn it to the right or left as desired and operate the shutter release either with your middle finger or thumb, depending on the camera's position.

Photographs without a tripod should only be taken with shutter speeds of $\frac{1}{60}$ to $\frac{1}{500}$ sec., possibly $\frac{1}{30}$ sec. too. If you have a steady hand you may be able to avoid camera shake at $\frac{1}{15}$ sec. by supporting your elbows somehow, but you must try that out for yourself.

DEPTH OF FIELD

We already mentioned large and small lens apertures (on page 8) in the choice of suitable shutter speed and aperture combinations.



Large aperture
e. g. f. 2.8 = big opening
but small
depth of field.



Small aperture
e. g. f. 22 = little opening
but great
depth of field.

As you will see from this example, depth of field is variable; it increases as the aperture becomes smaller and the distance becomes greater. To help you in finding out how far this zone of sharp focusing extends, your Super Solina has what is known as a depth of field scale (③, illustration page 5). From it you can find the approximate depth of field for any given lens aperture.

If, for example, you focus the camera to a distance of 15 feet with an aperture of f. 8, you look for the two numbers marked 8 on the depth of field scale and read off the range in feet between these two points on the adjacent focusing ring; in this case it will be about 10 to 30 ft.

SNAPSHOT SETTING

If the shutter speed initially selected gives an exposure reading in which the aperture can be set on the red dot between f. 8 and 11 or on f. 11 you can use the so-called snapshot or zone focusing setting.

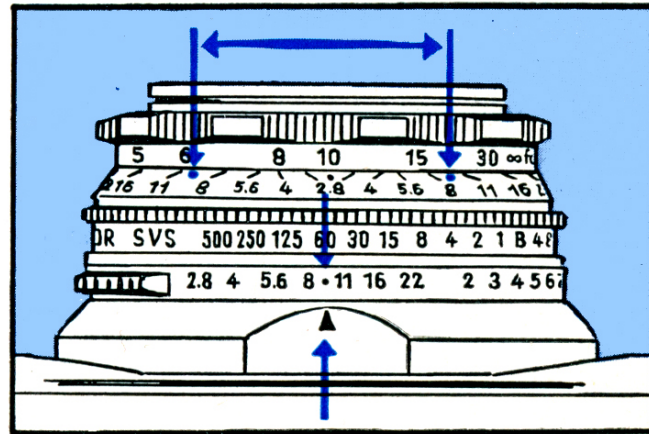

For this purpose the 10 feet and 30 feet markings are engraved in red on the focusing scale. When focused on 10 feet you obtain a sharp zone from 7 to 17 feet (see illustration); on 30 feet the depth of field is about 17 feet to Infinity.

This method is used for close-range and long distance photographs where you want to avoid focusing the camera at all.

Exact particulars of the depth of field obtainable at various apertures and distances can be seen from the table on pages 26/27.

DELAYED ACTION RELEASE

Sometimes you want to be in the picture yourself. Your Super Solina provides for this wish with its delayed action release. First place the camera on a tripod or other firm support and then set the lever (②, see main illustration) at "V" **after the film has been wound on**. As soon as you press the shutter release the small lever starts to move and operates the shutter automatically after about 7 seconds. The lever always returns to its original position and has to be re-set for every delayed action shot. Any of the instantaneous shutter speeds can be used with it, and those for flash. Time exposures (= B setting) cannot be made with the delayed action release mechanism.

THE RIGHT FILM FOR EVERY OCCASION

Before we explain how to load your Super Solina with film, here are a few hints on different kinds of film.

*First of all there is **Agfa Isopan F**, 40 ASA (17° DIN), a universal film of medium speed. It is a sharp, fine-grain film from which you can obtain good enlargements. In bad weather **Agfa Isopan ISS**, 100 ASA (21° DIN), is the right film. It allows you to use instantaneous shutter speeds or, when the sun is shining, smaller apertures to obtain greater depth of field.*

*For special needs there are special films to deal with difficult situations. When you want extra fine grain for enlargements **Agfa Isopan FF**, 16 ASA (13° DIN), is “your” film.*

*In very poor lighting conditions you can fall back on **Agfa Isopan Ultra**, 250 ASA (25° DIN), which combines extra high speed with very good sharpness.*

*If the worst comes to the worst and even the high speed of Isopan Ultra is not sufficient, you can use **Agfa Isopan Record**. It is of equal grain size and sharpness whilst giving just that little extra “something” in speed, enabling you to stop down more or use a higher shutter speed. Hints on its use are contained in the film package.*

***Agfacolor films** open up the world of colour to you. For more than twenty years these films have been great favourites because of the natural way they reproduce pastel tints and bright colours alike.*

*There are two film types. For home projection of colour transparencies you use **Agfacolor Reversal Film**. The CT 18 or CK film—that is how they are described in the trade—are rated at 50 ASA (18° DIN) and 40 ASA (17° DIN) respectively.*

The letter T indicates the daylight film, K the film for use in artificial light.

*If you wish to have colour paper prints for your album, the right film is **Agfacolor Negative Film CN 17**, a universal film for use in daylight, artificial light and flashlight.*

The correct way to load the camera with film is described on the next two pages.

HOW TO LOAD THE CAMERA

(only in subdued daylight, using body shadow on sunny days)

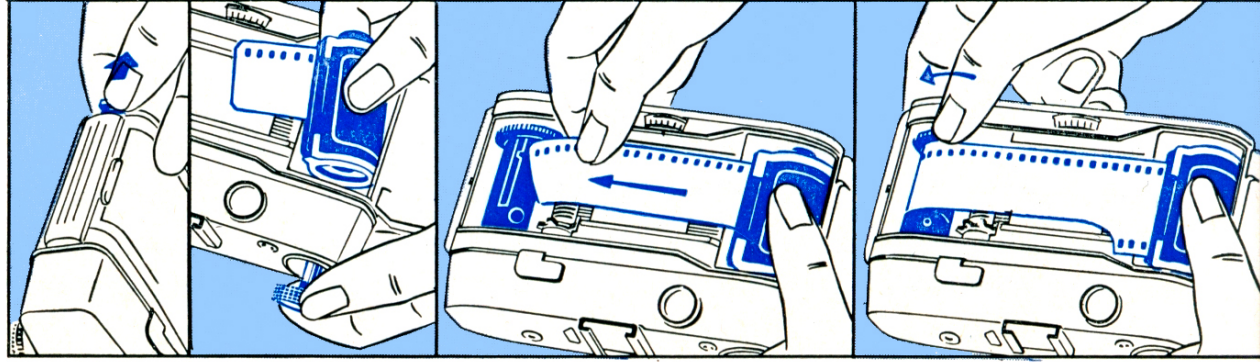

Open camera back by pulling the catch in direction shown by arrow.

Push locking button in direction of arrow (see illustration, p. 2). Draw out the rewinding knob with left hand as far as possible and insert the film cassette. Push back the rewinding knob.

Draw out enough film for the narrow tongue to reach the winding spool easily. Turn the spool by its milled ring until the broad slit and film perforation lug are uppermost.

Insert the film in the slit so that the lug engages in the second film perforation. Now turn the winding spool in the direction of the arrow until about ½ in. full width of film projects from the cassette.

Close the back of the camera by pressing until it snaps home.

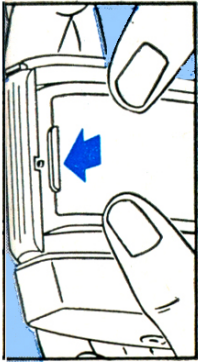

FILM TRANSPORT FOR THE FIRST EXPOSURE

Turn the disk of the film counter as described on page 3 until the tip of the green triangle—situated just in front of number 36 or 20 (depending on the length of the film)—is in line with the fixed mark on the camera back. Then operate the rapid transport lever as already described and press the shutter release. Repeat this process twice more and your camera is then ready for the first exposure

DOUBLE AND BLANK EXPOSURE LOCK

The Super Solina is equipped with a double and blank exposure lock. This makes it impossible to expose the same piece of film twice, moreover the film cannot be wound on without releasing the shutter. If therefore the release lever cannot be operated, you have either not yet wound the film on, or you previously failed to pull the rapid transport lever to its stop. This latter fault can be corrected by repeating this movement to its completion without losing any film. If you are nevertheless in doubt whether the film has been wound or not, it would be wrong to try the release lever, as this might lose you an exposure; instead, you should try to move the rapid transport lever. If this is locked, your Super Solina will be ready for the next picture.

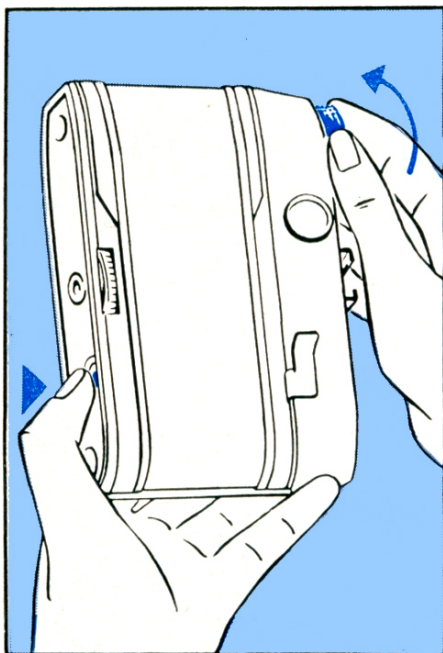

REWINDING THE FILM AFTER EXPOSURE

After the last exposure, shown by the zero on the film counter, the rapid transport lever will usually not move. The film is now on the winding spool and must be rewound into its light-tight cassette before opening the back of the camera. To do this, push the locking button in the direction of the arrow (see illustration, page 2) and pull the rewinding knob out **only about $\frac{1}{12}$ in.** to its first stop. Then press in the locking button in the base of the camera (see illustration) and turn the rewinding knob in the direction shown by the arrow. When it cannot be turned any further, rewinding is complete. You can now open the back of the camera, as described on page 20, pull out the rewinding knob as far as it will go and remove the cassette. Put the cassette in its light-tight packing and mark it as exposed.

SOME GENERAL HINTS FOR YOUR PHOTOGRAPHS

A very striking effect can be obtained if you photograph the subject by oblique sunlight. Of course you can also photograph with the sun behind you, but then you must be careful to keep your own shadow out of the picture. Photos against the light call for some experience because the rays of the sun should not fall directly on the lens. It is best to take advantage of the shadow of a tree or house and use a lens hood too.

Photographs without sunshine are also possible. With an overcast sky, contrast can be heightened by using a medium yellow or orange-red filter. Try out shots from a mountain peak or tower, including foreground interest of some kind. Think of the foreground in your landscape photos too, and enliven them by including a person, fence or other suitable object.

A change in the camera position also relieves the monotony. Try out "bird's-eye" or "worm's-eye" views at an oblique angle! Action photographs of processions and similar subjects are easier to take if you work out the most suitable distance, set the focusing ring to this figure and let the procession enter this sharp zone. This leaves you free to concentrate on the picture in the viewfinder and to press the shutter release at the moment when the diamond-shaped portion of the rangefinder gives a sharp image.

ACCESSORIES FOR YOUR SUPER SOLINA

You should not neglect to get an Ever-Ready Case. It not only protects your camera against shock and weather, but also makes it easier to carry. ▶



Agfa Filters as well as the Agfa Lens Hood with standard mounts are also available for your Super Solina. A practical leather case for lens hood and two filters can be conveniently fastened to the strap of the Ever-Ready Case. ▶

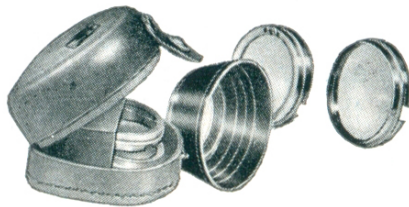

With your Super Solina it is child's play to capture the wondrous world of tiny objects: the Agfa Supplementary Lens enables you to take close-ups at ranges from 16 to 27 in. (40-27 cm.) and the parallax-adjusting viewfinder (Natarix) ensures accurate framing. ▶

The Agfalux Flashgun is small, light and easy to handle. A practical zipper case is also available. ▶

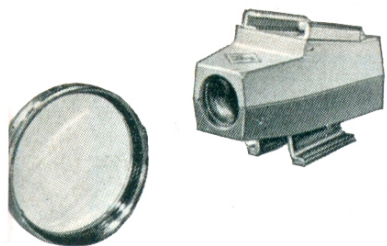

Developing your own films increases the pleasures of photography. With the Agfa Rondix or Agfa Rondinax 35 U you can actually develop them in daylight. ►

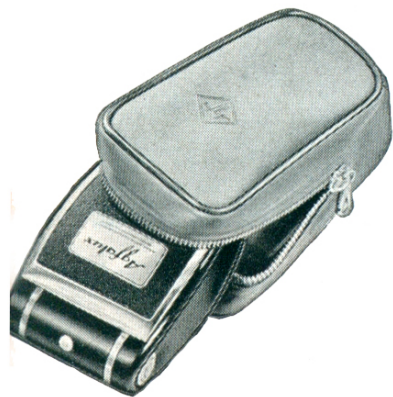
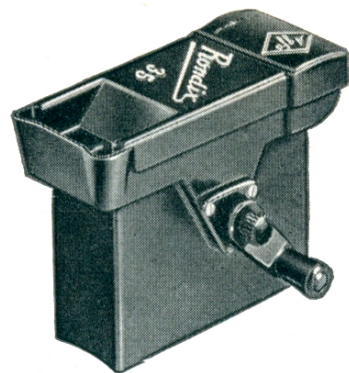

The finishing touch to your brilliant colour transparencies is provided by an Agfa projector, such as the high quality Agfa CP 35, with which you can re-live all the wonderful photos taken with your Super Solina. ►

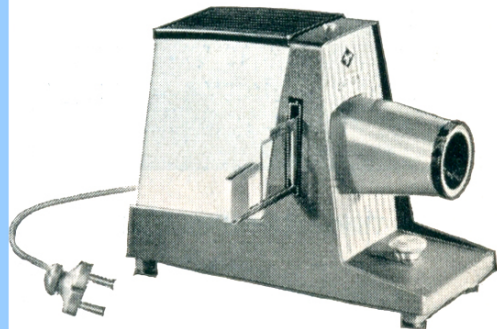

DEPTH OF FIELD ZONES FOR AGFA COLOR-APOTAR f. 2.8—45 mm

At a distance setting of	and stopping down to			
	f. 2.8	f. 4	f. 5.6	f. 8
	sharp definition is obtained from . . . ft. to . . . ft.			
3 ft.	2' 10 ³ / ₄ " — 3' 1 ¹ / ₄ "	2' 10 ¹ / ₂ " — 3' 1 ³ / ₄ "	2' 10" — 3' 2 ¹ / ₄ "	2' 9 ¹ / ₄ " — 3' 3 ¹ / ₂ "
3 ¹ / ₂ ft.	3' 4 ¹ / ₂ " — 3' 7 ³ / ₄ "	3' 4" — 3' 8 ¹ / ₄ "	3' 3 ¹ / ₄ " — 3' 9 ¹ / ₄ "	3' 2" — 3' 10 ³ / ₄ "
4 ft.	3' 10" — 4' 2 ¹ / ₄ "	3' 9 ¹ / ₄ " — 4' 3"	3' 8 ¹ / ₄ " — 4' 4 ¹ / ₂ "	3' 7" — 4' 6 ¹ / ₂ "
5 ft.	4' 8 ³ / ₄ " — 5' 3 ¹ / ₂ "	4' 7 ³ / ₄ " — 5' 5"	4' 6 ¹ / ₄ " — 5' 7 ¹ / ₄ "	4' 4" — 5' 10 ³ / ₄ "
6 ft.	5' 7 ¹ / ₄ " — 6' 5 ¹ / ₂ "	5' 6" — 6' 7 ¹ / ₂ "	5' 3 ³ / ₄ " — 6' 10 ³ / ₄ "	5' 3 ³ / ₄ " — 7' 4 ¹ / ₂ "
8 ft.	7' 3 ¹ / ₂ " — 8' 10 ¹ / ₄ "	7' 1 ¹ / ₄ " — 9' 2"	6' 9 ¹ / ₂ " — 9' 8 ³ / ₄ "	6' 4 ³ / ₄ " — 10' 8 ³ / ₄ "
10 ft.	8' 11" — 11' 4 ¹ / ₂ "	8' 7 ¹ / ₂ " — 11' 11"	8' 2" — 12' 10 ³ / ₄ "	7' 7" — 14' 9"
15 ft.	12' 8" — 18' 4 ³ / ₄ "	12' 3 ¹ / ₄ " — 19' 10 ¹ / ₄ "	11' 2 ¹ / ₄ " — 22' 9 ³ / ₄ "	10' 1 ¹ / ₄ " — 29' 5 ¹ / ₄ "
30 ft.	21' 10 ¹ / ₄ " — 47' 11 ¹ / ₂ "	20' 1" — 59' 7 ¹ / ₄ "	17' 8 ³ / ₄ " — ∞	15' 1 ¹ / ₄ " — ∞
∞	59' — ∞	47' 6" — ∞	36' 1 ¹ / ₄ " — ∞	26' 6 ¹ / ₂ " — ∞

The subject distance is measured from the film plane (rear edge of the accessory shoe).

DEPTH OF FIELD ZONES FOR AGFA COLOR-APOTAR f. 2.8—45 mm

At a distance setting of	and stopping down to		
	f. 11	f. 16	f. 22
	sharp definition is obtained from ... ft. to ... ft.		
3 ft.	2' 8 ¹ / ₄ " — 3' 4 ³ / ₄ "	2' 6 ³ / ₄ " — 3' 7 ¹ / ₂ "	2' 5 ¹ / ₄ " — 3' 11 ¹ / ₄ "
3 ¹ / ₂ ft.	3' 3 ³ / ₄ " — 4' 1"	2' 11" — 4' 5"	2' 8 ³ / ₄ " — 4' 10 ³ / ₄ "
4 ft.	3' 5 ¹ / ₄ " — 4' 9 ¹ / ₂ "	3' 2 ³ / ₄ " — 5' 3 ¹ / ₄ "	3' 1 ¹ / ₄ " — 5' 11 ³ / ₄ "
5 ft.	4' 1 ³ / ₄ " — 6' 4"	3' 10" — 7' 2 ³ / ₄ "	3' 6 ¹ / ₂ " — 8' 8 ¹ / ₂ "
6 ft.	4' 9 ¹ / ₂ " — 8' 1"	4' 4 ¹ / ₂ " — 9' 7 ¹ / ₄ "	4' — 12' 5 ¹ / ₂ "
8 ft.	5' 11 ¹ / ₄ " — 12' 3 ³ / ₄ "	5' 4" — 16' 4 ¹ / ₂ "	4' 9" — 27' 2 ¹ / ₄ "
10 ft.	6' 11 ¹ / ₂ " — 17' 11 ¹ / ₂ "	6' 1 ¹ / ₂ " — 28' 3 ³ / ₄ "	5' 4 ¹ / ₄ " — 93' 2"
15 ft.	9' — 46' 2 ¹ / ₂ "	7' 7 ¹ / ₂ " — ∞	6' 5 ¹ / ₂ " — ∞
30 ft.	13' 1" — ∞	10' 1 ¹ / ₂ " — ∞	8' 1 ³ / ₄ " — ∞
∞	19' 11 ³ / ₄ " — ∞	14' 2" — ∞	10' 6 ¹ / ₄ " — ∞

The subject distance is measured from the film plane (rear edge of the accessory shoe).

SHORT GUIDE

1. Set the film indicator disk.
2. To insert film, open camera back.
3. Insert cassette, thread the beginning of the film into the take-up spool. Shut camera back, set exposure counter at the green triangle.
4. Make two exposures by operating rapid winding lever and release button.
5. Insert camera in ever-ready case and screw tight.
6. Estimate, or better measure the exposure.
7. Set the determined exposure value.
8. Check whether exposure time/stop combination meets the need of the exposure subject, e. g. landscape: large depth of field = small stop, i. e. slow shutter speed, or sports subjects: fast shutter speed = large stop, i. e. little depth of field.
9. Take aim at the subject through the bright-line viewfinder.
10. Focus with the aid of the coupled rangefinder. Assume a firm stance, take a deep breath, hold it, depress release lever slowly as far as it will go.
11. Close ever-ready case.

We reserve the right to make structural alterations to the Super Solina arising from further development of the camera.

AGFA AKTIENGESELLSCHAFT
Camera-Werk Muenchen

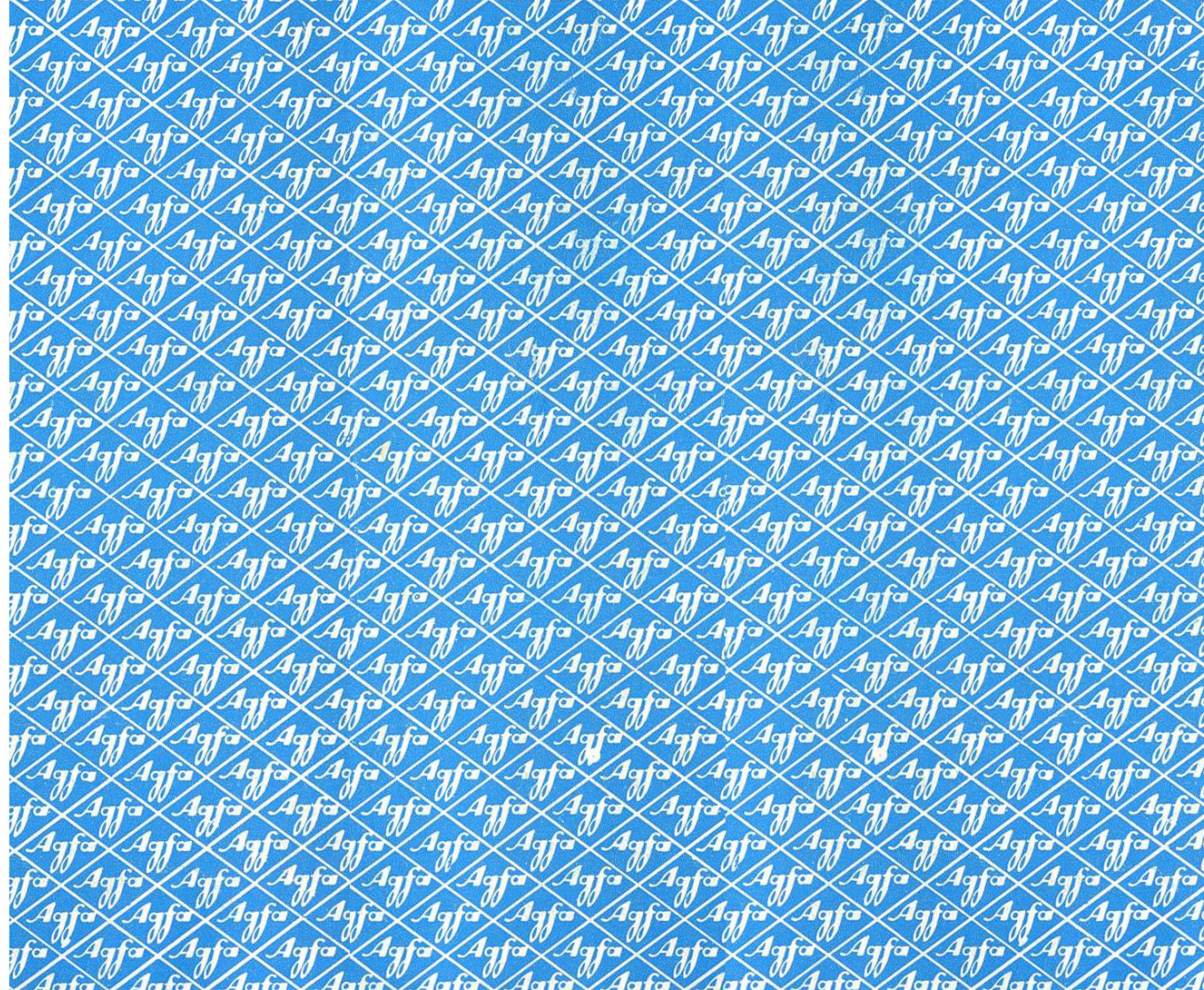

AGFA AKTIENGESELLSCHAFT
CAMERA-WERK MÜNCHEN

1734 engl. - 0160

MADE IN GERMANY